Unsolicited Information

Project	Amazon Data Services Ireland Limited, Clonshaugh Business and Technology Park, Dublin D17, Dublin, Dublin. Reg. No.: P1186-01
Subject	Unsolicited Information
Author	Jonathan Gauntlett
Date	26 January 2023
Ref.	JG/217501.1055TR11

1.0 INTRODUCTION:

This document sets out additional unsolicited information in respect of the Industrial Emissions licence application (Reg. No.: P1186-01) from Amazon Data Services Ireland Limited for an installation located at Amazon Data Services Ireland Limited, Clonshaugh Business and Technology Park, Dublin D17.

Evaporative cooling systems

An assessment has been undertaken of the potential for water quality impacts as a result of the discharge of evaporative cooling water to stormwater sewer. The Technical Note: Stormwater Impact Assessment; is included with this unsolicited information.

Process Water Flow

Mains water is used on site for both domestic purposes (offices and kitchens) and for data hall cooling at ambient temperatures above a set point. No treatment chemicals are added to the cooling water.

When water is used for cooling, it is recirculated in a closed loop system. Cooling water has **estimated** conductivity values of between 1,200-1,500 $\mu\text{S}/\text{cm}$. Cooling water is discharged at ambient temperature to the storm water sewer.

Figure 1 presents the cooling water system.

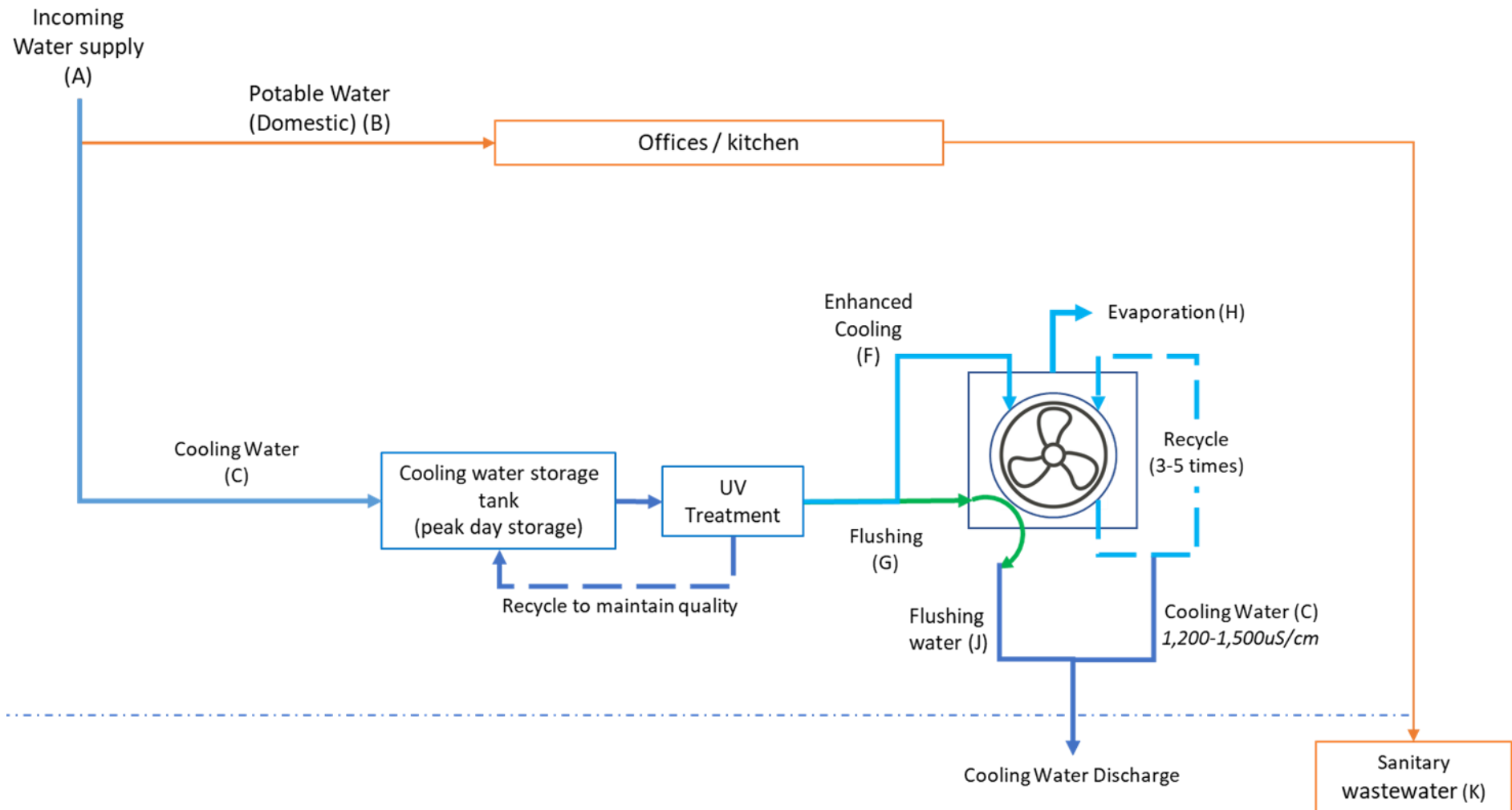

Figure 1.1 Water Use

Prevention of Accidents

The Standard Operating Procedure (SOP) 'Fuel intake at main Storage Tank' for the diesel unloading operations at the installation has been attached to this submission.

Ownership of Newbury Substation Lands

The Newbury 110 kV Substation is constructed on lands held by ADSIL under a lease expiring in 2026.

Additional Information regarding Drainage Systems

Legionella Management

In accordance with ADSIL legionella management procedure, every cooling system is sampled annually for legionella bacteria. If a result exceeds 1000CFU/L, the air handling unit is disinfected with a hydrogen peroxide solution. Based on past experience, disinfection is required on approximately 10% of systems annually. During the disinfection process, 50 ml of hydrogen peroxide solution is dosed into the air handling unit and water is recirculated through the cooling system. The disinfected water is discharged to the cooling system drain and ultimately to the storm network. Any residual hydrogen peroxide is oxidised by organics in the onsite storm drainage network and converted to water and oxygen prior to discharge via storm sewer.

Flue drainage discharge

Rainfall which passes through the back-up generator exhaust stacks for Building Y and a small no. of generator exhaust stacks for Building W will discharge to the storm water drainage network via hydrocarbon interceptors. For Building X and the majority of Building W the back-up generator exhausts are horizontal which prevents rainwater entering the generator flue.

How does ADSIL record Run Hours

The emergency backup generator operating hours are recorded on the Enterprise Asset Management System (EAM). For each generator, the Operation's Team manually enters planned and emergency run hours and the description of the operation (run reason) onto the EAM system.

The environmental team must approve all generator operation associated with on-load planned maintenance/testing to ensure the run hours do not exceed what is allowed under the site's planning permission. This is done automatically on ADSIL's internal maintenance approval system platform. The Operation teams must attach an excel spreadsheet to the approval request which shows all of the maintenance/testing events and associated run hours for the year to date. This 'Run Hour Spreadsheet' is maintained by the Operations Team.

When an emergency operation is logged, an email alert is sent to the Environmental Team for review and tracking. The Operations team also maintain an excel spreadsheet on which they record every emergency operation of a generator. The environmental team review this information after every emergency event.

ADSIL's Climate Commitments: Sustainability in the Cloud

Amazon Web Services AWS is focused on efficiency and continuous innovation across global infrastructure, as we continue on our path to powering our operations with 100%

renewable energy by 2025. AWS is committed to achieving Amazon's goal of net-zero carbon by 2040. More about these commitments and sustainability in the cloud can be found here: <https://aws.amazon.com/sustainability/>.

AWS is committed to building a sustainable business for their customers and the planet. In 2019, the Operator co-founded The Climate Pledge—a commitment to be net zero carbon across their business by 2040, 10 years ahead of the Paris Agreement. Part of that commitment is powering the Operator's global cloud infrastructure with 100% renewable energy, including in Ireland. As part of this commitment, the Operator is investing and innovating in efficiency in every aspect of their operations and is on a path to be powered by 100% renewable energy by 2025 – five years ahead of its original target of 2030, Amazon is the largest corporate purchaser of renewable energy in the world and has announced a total of 379 renewable energy projects across 21 countries globally, representing 18.5 gigawatts (GW) of renewable energy capacity. Once fully operational, Amazon's global renewable energy portfolio will generate 50,000 gigawatt hours (GWh) of clean energy, which is the equivalent amount of electricity needed to power 4.6 million U.S. homes each year. Amazon was the first company in Ireland to deliver unsubsidised Corporate Power Purchase Agreements (CPPAs). This means Amazon is helping to add renewable energy to the grid without direct government support, thus reducing subsidy costs on other local energy users. In Ireland alone, Amazon has committed to offtake 100% of the power from renewable wind projects in Cork, Donegal, and Galway. Amazon does not own these projects, but our commitment to purchasing the power from these projects enable them to be built. In total, these three wind projects are projected to add 229 megawatts of renewable energy to the Irish grid, reducing carbon emissions by 366,000 tonnes of CO₂ each year, and producing enough renewable energy to power 185,000 Irish homes, per annum. These three wind projects will make Amazon the largest single corporate buyer of renewable energy in the country.

ADSIL's Customers are able to support their own goals to become sustainable by moving to the cloud. The results of a recent study of US enterprise data centres by 451 Research found the Operator's data storage facilities to be 3.6 times more energy efficient than the traditional alternative and achieved an 88% reduction in carbon footprint for workloads that moved from on-premises data storage to the Operator's, helping the Operator's customers to become greener in the cloud.

To reduce both the energy and water use in their Irish data centres, the Operator utilises direct evaporative cooling systems, which predominately utilizes outside air to cool the servers. This means that for more than 95% of the year they use no water to cool their data centres in Ireland. Furthermore, the proposed buildings are designed to harvest up to 95% of the annual cooling water requirements through rainwater harvesting.

Biofuel Use

ADSIL has recently participated in a pilot study to test the suitability of Renewable Diesel use within their emergency back-up generator fleet. Renewable diesel burns cleaner than regular diesel, releasing less carbon and potentially reducing CO₂ emissions. Following positive outcomes of the pilot tests, ADSIL are progressing to secure a supply of Renewable Diesel which will be used in their backup generators. ADSIL's preference will be to use Renewable Diesel as this is a more sustainable option to traditional diesel as far as is possible, however this will be dependent on the availability of supply.