



TECHNICAL MANUAL

EN



The above picture is only for reference.

REX/REX F/REX K/REX K F

REX DUAL/REX DUAL F

PRESSURISED STEEL BOILERS



INDEX

1	INTRODUCTION	3
2	SAFETY WARNINGS	3
3	GENERAL WARNINGS	5
4	TECHNICAL SPECIFICATIONS	6
4.1	REX/REX K/REX F/REX K F 7-130 BOILER.....	6
4.2	REX/REX K/REX F/REX K F 140-350 BOILER.....	8
4.3	REX 400-600 BOILER.....	9
4.4	REX DUAL/REX DUAL F (STAKED) 14-170 BOILER.....	10
4.5	REX DUAL/REX DUAL F (SIDE BY SIDE) 80-260 BOILER.....	12
5	INSTALLATION	14
5.1	THERMAL PLANT.....	14
5.1.1	BOILER ROOM.....	14
5.1.2	FLUE.....	14
5.2	HYDRAULIC CONNECTION.....	15
5.2.1	Hot water heating system with closed expansion vessel - Furnace output \leq 300,000 kcal/h.....	15
5.2.2	Hot water heating system with closed expansion vessel - Furnace output $>$ 300,000 kcal/h.....	15
5.2.3	REX DUAL/REX DUAL F (side by side) 80-260 POSITIONING INSTRUMENTS.....	16
5.3	ELECTRICAL CONNECTION.....	17
5.4	REX/REX F/REX K/REX K F OPTIONAL CONTROL PANEL.....	17
5.5	INSTALLATION OF REX 140-350 BOILER CONTROL PANEL.....	18
5.6	REX/REX F 400-600 CONTROL PANEL.....	20
5.7	REX DUAL/REX DUAL F OPERATING PRINCIPLES.....	21
5.7.1	REX DUAL/REX DUAL F OPTIONAL CONTROL PANEL.....	21
5.8	DOOR.....	22
5.8.1	DOOR OPENING.....	22
5.8.2	DOOR OPENING REVERSAL (to the right).....	22
5.8.3	DOOR ADJUSTMENT (opening on the right).....	23
5.9	BURNER CONNECTION.....	24
6	ASSEMBLY	25
6.1	REX K/REX K F ASSEMBLY.....	25
6.2	REX/REX F/REX K/REX K F BOILER CASINGS AND CONTROL PANEL.....	27
6.3	REX DUAL/REX DUAL F BOILER CASINGS AND CONTROL PANEL.....	31
7	START UP	33
7.1	PRELIMINARY CHECKS.....	33
7.2	WATER TREATMENT.....	33
7.3	FILLING THE SYSTEM.....	33
8	OPERATION	34
8.1	OPERATING CHECKS.....	34
9	MAINTENANCE	36
9.1	PREPARATION FOR INSPECTION AND MAINTENANCE.....	36
9.2	ORDINARY.....	37
10	QR CODE	38

1 INTRODUCTION

Dear Customer,

Thank you for having chosen our **generator**.

In your interests, we invite you to follow and observe the instructions in this manual to ensure the highest level of efficiency and duration of the unit.

IMPORTANT: failure to observe the instructions in this manual will void the warranty conditions.

2 SAFETY WARNINGS



IMPORTANT

For safety and for proper operation, carefully read this **TECHNICAL MANUAL** before installing and starting the generator.

The manual is an integral and essential part of the generator and must accompany it from installation until disposal. The generator must be used for the purpose for which it was strictly intended and any liability by the Manufacturer for damages to people, animals or property due to lack of maintenance or for improper use, is excluded.



Safety of the thermal power plant

For safety purposes, the qualified technical personnel in charge of running the system must consider the following requirements:

- Follow the accident prevention and environmental safety regulations in force.
- Ensure the generator installation in the thermal power plant complies with the standards in force.
- Ensure that the electrical and hydraulic system complies with the standards in force.
- Ensure that the boiler room complies with the standards in force and is sufficiently ventilated.
- Ensure that the boiler fumes are conveyed outside the thermal power plant through a flue compliant with the standards in force.
- Ensure that the acidic condensation that may develop during system start-up, is evacuated outside the thermal power plant after a neutralisation process in compliance with the standards in force.
- Ensure that there is no danger due to frost inside the thermal power plant.



System check

Before switching on the generator for the first time, a duly qualified technician must perform a check at the central heating plant and update the system log once the check is over.



Periodic verifications

The generator must be periodically checked by a duly qualified technician (maintenance worker), who should update the system log once the check is over.



Danger of explosion

Routine and extraordinary maintenance must be entrusted to **professionally qualified personnel** with the purpose of promptly detecting any damage to the generator's pressurised body and the safety and control accessories.



Danger deriving from the fuel

Sensing the presence of fuel in the thermal power plant, it is appropriate to follow the precautions below to avoid the risk of explosions and fires:

- Do not smoke or cause sparks.
- Do not turn on lights or electrical devices in general (mobile phones).
- Open doors and windows.
- Close the fuel shut-off valve normally placed outside the thermal power plant.
- Disconnect the electrical power supply by using the switch normally placed outside the thermal power plant.



Danger of burns

During normal operation, the generator has hot parts that, upon accidental contact without suitable personal protection, can cause serious burns. Potentially hot parts include:

- Accessories and valves connected to the generator.
- Door and smoke chamber.



Danger from fumes

An incorrect adjustment of the closing door or an insufficient draught in the flue can leave fumes inside the thermal power plant, causing fatal intoxication deriving from carbon monoxide which, by its nature, is colourless and odourless. Therefore, ensure the generator is properly installed and adjusted and the presence of ventilation openings in the thermal power plant are compliant with the regulations in force.



Repairs

Any generator repair must be carried out or authorised by the manufacturer in order to avoid risks to people and property, as well as to prevent **voiding the Warranty Conditions being** . Generator maintenance must be entrusted to competent personnel.



Spare parts

In order to ensure maximum safety and reliability, it is essential that all removable defective accessories and parts are replaced with **Original Spare Parts** supplied by the Manufacturer.

For inspection purposes only.
Consent of copyright owner required for any other use.

3 GENERAL WARNINGS

Each generator is provided with a **manufacture plate** that can be found in the envelope with the boiler documents. The plate lists:

- Serial number or identification code;
- Rated thermal output in kcal/h and in kW;
- Furnace thermal output in kcal/h and in kW;
- Types of fuels that can be used;
- Max operating pressure.

A **manufacture certificate** is also provided which certifies the hydraulic test positive performance.

The installation must be performed in compliance with the regulations in force by **professionally qualified personnel**. The term “professionally qualified personnel” means persons with specific technical skills in the sector of heating system components.

Incorrect installation may cause damage to persons, animals or objects for which the manufacturer cannot be held responsible.

At the first start up, all regulation and control devices positioned on the control panel should be checked for efficiency. The **guarantee** shall be valid only upon compliance with the instruction given in this manual.

Our boilers have been built and tested in observance of EEC requirements and, as a consequence, CE-marked. EEC directives are as follows:

- **Directive on Gas** 2009/142/CE (Rif. EN 303)
- **Directive on Output** 92/42/EEC
- **Directive on Electromagnetic Compatibility** 2014/30/UE
- **Directive on Low Voltage** 2014/35/UE

IMPORTANT: This boiler has been designed to heat hot water at a temperature inferior to the boiling temperature at atmospheric pressure and must be connected to a heating plant and/or a domestic hot water plant within the limits of its performance and output.

ATTENTION: REX F, REX K F and REX DUAL F models featuring aluminum finned extrusions in their fire tubes (Fin-e patented) are suitable exclusively for use with gaseous fuels.

Consent of Copyright owner Required for any other use.
For inspection purposes only.

4 TECHNICAL SPECIFICATIONS

4.1 REX/REX K/REX F/REX K F 7-130 BOILER

Characteristics		Heat output		Heat input		Efficiency 100% (N.C.V.)	Effic. 100% (stars)	NG max flow rate G20	NG max flow rate G30	NG max flow rate G31	Max flow rate of flues	Max fluid flow	Min. fluid flow	Efficiency at 30% (N.C.V.)	
		u.m.	kW	kcal/h	kW	kcal/h	%	Stm ³ /h	kg/h	kg/h	kg/h	kg/h	kg/h	%	
		NOTE	Medium Temp. 70°C				Medium Temp. 70°C	(Efficiency Dir. 92/42/CEE)						Medium Temp. 70°C	
REX 7	REX K 7	(3) *	70	60.000	76	65.360	92,11	**	8,04	5,97	5,90	119,80	6000	2400	91,40
REX 8	REX K 8	(3) *	80	69.000	87	74.820	91,95	**	9,21	6,83	6,76	137,23	6900	2760	91,50
REX 9	REX K 9	(3) *	90	77.000	98	84.280	91,84	**	10,37	7,70	7,61	154,51	7700	3080	91,55
REX 10	REX K 10	(3) *	100	86.000	109	93.740	91,74	**	11,53	8,56	8,47	171,80	8600	3440	91,66
REX 12	REX K 12	(3)	120	103.000	130	111.800	92,31	**	13,76	10,21	10,10	205,02	10300	4120	91,45
REX 15	REX K 15	(3)	150	129.000	163	140.180	92,02	**	17,25	12,80	12,66	257,03	12900	5160	91,30
REX 20	REX K 20	(3)	200	172.000	216	185.760	92,59	**	22,86	16,96	16,78	340,61	17200	6880	91,36
REX 25	REX K 25	(3)	250	215.000	271	233.060	92,25	**	28,68	21,28	21,05	427,33	21500	8600	91,70
REX 30	REX K 30	(3)	300	258.000	325	279.500	92,31	**	34,39	25,53	25,25	512,41	25800	10320	91,90
REX 35	REX K 35	(3)	350	301.000	379	325.940	92,35	**	40,11	29,77	29,44	597,64	30100	12040	91,90
REX 40	REX K 40	(3)	420	361.000	455	391.008	92,38	-	48,11	35,71	35,32	716,84	36100	14440	91,80
REX 50	REX K 50	(3)	500	430.000	542	466.120	92,25	-	57,35	42,57	42,11	854,52	43000	17200	91,90
REX 62	REX K 62	(3)	620	533.000	672	577.920	92,26	-	71,11	52,78	52,21	1059,54	53300	21320	91,80
REX 75	REX K 75	(3)	750	645.000	813	699.180	92,25	-	86,03	63,85	63,16	1281,85	64500	25800	91,80
REX 85	REX K 85	(3)	850	731.000	921	792.060	92,29	-	97,46	72,33	71,55	1452,15	73100	29240	91,80
REX 95	REX K 95	(3)	950	817.000	1030	885.800	92,23	-	108,99	80,89	80,02	1623,95	81700	32680	91,70
REX 100	REX K 100	(3)	1020	877.000	1106	951.160	92,22	-	117,04	86,86	85,92	1743,90	87700	35080	91,90
REX 120	REX K 120	(3)	1200	1.032.000	1301	1.118.860	92,24	-	137,67	102,18	101,07	2051,28	103200	41280	91,80
REX 130	REX K 130	(3)	1300	1.118.000	1409	1.211.740	92,26	-	149,10	110,66	109,46	2221,59	111800	44720	91,70

Characteristics		Pressure losses flue gas side	Heat losses through the chimney	Heat losses through the casing	Heat losses with burner off	Flue gas temp. at boiler output and air at 20 deg. C			CO2			Press. losses fluid side	Design Pressure	Total capacity	Total weight	Electric supply	Frequency	Insulation class	Electric power	Fuel				
		mbar	%	%	%	°C	°C	°C	%	%	%	mbar	bar	l	kg	Volt ~	Hz	IP	W	With electr. contr. (excluded pump and burner)	Nat. gas	Lpg	Gasoil	Heavy oil
						GAS	GASOIL	HEAVY OIL	GAS	GASOIL	HEAVY OIL	(ΔT=12K)												
REX 7	REX K 7	0,8	7,09	0,80	0,10	188	191	191	10,5	13,5	14,0	8	5	105	216	230	50	IP40	20	X	X	X	X	
REX 8	REX K 8	1,0	7,25	0,80	0,10	192	195	194	10,5	13,5	14,0	10	5	105	216	230	50	IP40	20	X	X	X	X	
REX 9	REX K 9	0,8	7,36	0,80	0,10	194	197	197	10,5	13,5	14,0	13	5	123	258	230	50	IP40	20	X	X	X	X	
REX 10	REX K 10	1,0	7,46	0,80	0,10	197	199	199	10,5	13,5	14,0	16	5	123	258	230	50	IP40	20	X	X	X	X	
REX 12	REX K 12	1,1	6,89	0,80	0,10	184	186	186	10,5	13,5	14,0	23	5	123	258	230	50	IP40	20	X	X	X	X	
REX 15	REX K 15	1,2	7,18	0,80	0,10	190	193	193	10,5	13,5	14,0	33	5	172	346	230	50	IP40	20	X	X	X	X	
REX 20	REX K 20	1,9	6,61	0,80	0,10	177	180	180	10,5	13,5	14,0	63	5	172	346	230	50	IP40	20	X	X	X	X	
REX 25	REX K 25	2,0	6,95	0,80	0,10	185	188	187	10,5	13,5	14,0	98	5	220	431	230	50	IP40	20	X	X	X	X	
REX 30	REX K 30	2,0	6,89	0,80	0,10	184	186	186	10,5	13,5	14,0	50	5	300	475	230	50	IP40	20	X	X	X	X	
REX 35	REX K 35	2,9	6,85	0,80	0,10	183	186	185	10,5	13,5	14,0	67	5	356	542	230	50	IP40	20	X	X	X	X	
REX 40	REX K 40	4,5	6,82	0,80	0,10	182	185	184	10,5	13,5	14,0	42	5	360	584	230	50	IP40	20	X	X	X	X	
REX 50	REX K 50	4,2	6,95	0,80	0,10	185	188	187	10,5	13,5	14,0	60	5	540	853	230	50	IP40	20	X	X	X	X	
REX 62	REX K 62	6,4	6,94	0,80	0,10	185	188	187	10,5	13,5	14,0	92	5	645	963	230	50	IP40	20	X	X	X	X	
REX 75	REX K 75	5,2	6,95	0,80	0,10	185	188	187	10,5	13,5	14,0	55	5	855	1205	230	50	IP40	20	X	X	X	X	
REX 85	REX K 85	7,2	6,91	0,80	0,10	184	187	187	10,5	13,5	14,0	71	5	855	1205	230	50	IP40	20	X	X	X	X	
REX 95	REX K 95	5,2	6,97	0,80	0,10	185	188	188	10,5	13,5	14,0	89	5	950	1417	230	50	IP40	20	X	X	X	X	
REX 100	REX K 100	4,0	6,98	0,80	0,10	186	189	188	10,5	13,5	14,0	42	5	1200	1843	230	50	IP40	20	X	X	X	X	
REX 120	REX K 120	5,5	6,96	0,80	0,10	185	188	188	10,5	13,5	14,0	58	5	1200	1843	230	50	IP40	20	X	X	X	X	
REX 130	REX K 130	6,5	6,94	0,80	0,10	185	188	187	10,5	13,5	14,0	68	5	1200	1843	230	50	IP40	20	X	X	X	X	

Characteristics		Heat output		Heat input		Efficiency 100% (N.C.V.)	Effic. 100% (stars)	NG max flow rate G20	NG max flow rate G30	NG max flow rate G31	Max flow rate of flues	Max fluid flow	Min. fluid flow	Efficiency at 30% (N.C.V.)	
		u.m.	kW	kcal/h	kW	kcal/h	%	Stm ³ /h	kg/h	kg/h	kg/h	kg/h	kg/h	%	
		NOTE	Medium Temp. 70°C				Medium Temp. 70°C	(Efficiency Dir. 92/42/CEE)						Medium Temp. 70°C	
REX 7 F	REX K 7 F	(3) *	70	60.000	74,2	63.812	94,34	***	7,85	5,83	5,76	116,97	6000	2400	94,80
REX 8 F	REX K 8 F	(3) *	80	69.000	84,7	72.842	94,45	***	8,96	6,65	6,58	133,50	6900	2760	94,70
REX 9 F	REX K 9 F	(3) *	90	77.000	95,2	81.872	94,54	***	10,07	7,48	7,40	150,04	7700	3080	95,00
REX 10 F	REX K 10 F	(3) *	100	86.000	105,6	90.816	94,70	***	11,17	8,29	8,20	166,43	8600	3440	94,80
REX 12 F	REX K 12 F	(3)	120	103.000	126,5	108.790	94,86	***	13,39	9,94	9,83	199,51	10300	4120	95,10
REX 15 F	REX K 15 F	(3)	150	129.000	157,8	135.708	95,06	***	16,70	12,39	12,26	248,83	12900	5160	95,70
REX 20 F	REX K 20 F	(3)	200	172.000	210	180.600	95,24	***	22,22	16,49	16,31	331,08	17200	6880	95,30
REX 25 F	REX K 25 F	(3)	250	215.000	263,5	226.610	94,88	***	27,88	20,69	20,47	415,41	21500	8600	95,38
REX 30 F	REX K 30 F	(3)	300	258.000	315,5	271.330	95,09	***	33,39	24,78	24,51	497,51	25800	10320	95,59
REX 35 F	REX K 35 F	(3)	350	301.000	367	315.620	95,37	***	38,84	28,82	28,51	578,72	30100	12040	95,60
REX 40 F	REX K 40 F	(3)	420	361.000	441	379.260	95,24	-	46,67	34,64	34,26	695,38	36100	14440	95,40
REX 50 F	REX K 50 F	(3)	500	430.000	524	450.640	95,42	-	55,45	41,15	40,71	826,21	43000	17200	95,70
REX 62 F	REX K 62 F	(3)	620	533.000	649	558.140	95,53	-	68,68	50,97	50,42	1023,33	53300	21320	95,90
REX 75 F	REX K 75 F	(3)	750	645.000	786	675.960	95,42	-	83,17	61,73	61,06	1239,23	64500	25800	95,92
REX 85 F	REX K 85 F	(3)	850	731.000	891	766.260	95,40	-	94,29	69,98	69,22	1404,92	73100	29240	95,80
REX 95 F	REX K 95 F	(3)	950	817.000	997	857.420	95,29	-	105,50	78,30	77,45	1571,95	81700	32680	95,79
REX 100 F	REX K 100 F	(3)	1020	877.000	1069	919.340	95,42	-	113,12	83,96	83,05	1685,49	87700	35080	95,80
REX 120 F	REX K 120 F	(3)	1200	1.032.000	1259	1.082.740	95,31	-	133,23	98,88	97,81	1985,13	103200	41280	95,81
REX 130 F	REX K 130 F	(3)	1300	1.118.000	1364	1.173.040	95,31	-	144,34	107,13	105,97	2150,67	111800	44720	95,70

(3) Door opening reversible

Characteristics		Pressure losses	Heat losses through the chimney	Heat losses through the casing	Heat losses with burner off	Flue gas temp. at boiler output and air at 20 deg. C	CO2	Press. losses fluid side	Design Pressure	Total capacity	Total weight	Electric supply	Frequency	Insulation class	Electric power	Fuel			
		mbar	%	%	%	°C	%	mbar	bar	l	kg	Volt ~	Hz	IP	W	Nat. gas	LPG	Gasoil	Heavy oil
						GAS	GAS	(ΔT=12K)								With electr. contr. (excluded pump and burner)			
REX 7 F	REX K 7 F	0,9	5,16	0,50	0,10	148	11,0	8	5	105	222	230	50	IP40	20	X	X	-	-
REX 8 F	REX K 8 F	1,1	5,05	0,50	0,10	146	11,0	10	5	105	222	230	50	IP40	20	X	X	-	-
REX 9 F	REX K 9 F	0,9	4,96	0,50	0,10	143	11,0	13	5	123	266	230	50	IP40	20	X	X	-	-
REX 10 F	REX K 10 F	1,1	4,80	0,50	0,10	140	11,0	16	5	123	266	230	50	IP40	20	X	X	-	-
REX 12 F	REX K 12 F	1,3	4,64	0,50	0,10	136	11,0	23	5	123	266	230	50	IP40	20	X	X	-	-
REX 15 F	REX K 15 F	1,3	4,44	0,50	0,10	131	11,0	35	5	172	357	230	50	IP40	20	X	X	-	-
REX 20 F	REX K 20 F	2,2	4,26	0,50	0,10	127	11,0	63	5	172	357	230	50	IP40	20	X	X	-	-
REX 25 F	REX K 25 F	2,4	4,62	0,50	0,10	135	11,0	98	5	220	442	230	50	IP40	20	X	X	-	-
REX 30 F	REX K 30 F	2,4	4,41	0,50	0,10	130	11,0	50	5	300	489	230	50	IP40	20	X	X	-	-
REX 35 F	REX K 35 F	3,4	4,13	0,50	0,10	124	11,0	67	5	356	558	230	50	IP40	20	X	X	-	-
REX 40 F	REX K 40 F	5,2	4,26	0,50	0,10	127	11,0	42	5	360	600	230	50	IP40	20	X	X	-	-
REX 50 F	REX K 50 F	4,8	4,08	0,50	0,10	122	11,0	60	5	540	871	230	50	IP40	20	X	X	-	-
REX 62 F	REX K 62 F	7,3	3,97	0,50	0,10	120	11,0	92	5	645	981	230	50	IP40	20	X	X	-	-
REX 75 F	REX K 75 F	5,8	4,08	0,50	0,10	122	11,0	55	5	855	1230	230	50	IP40	20	X	X	-	-
REX 85 F	REX K 85 F	8,0	4,10	0,50	0,10	123	11,0	71	5	855	1230	230	50	IP40	20	X	X	-	-
REX 95 F	REX K 95 F	5,9	4,21	0,50	0,10	126	11,0	89	5	950	1446	230	50	IP40	20	X	X	-	-
REX 100 F	REX K 100 F	4,5	4,08	0,50	0,10	122	11,0	42	5	1200	1880	230	50	IP40	20	X	X	-	-
REX 120 F	REX K 120 F	6,2	4,19	0,50	0,10	125	11,0	58	5	1200	1880	230	50	IP40	20	X	X	-	-
REX 130 F	REX K 130 F	7,3	4,19	0,50	0,10	125	11,0	68	5	1200	1880	230	50	IP40	20	X	X	-	-

Dimensions				H	H1	H2	H4	H6	H10	L	L2	P	P2	P3	P4	P5	P6	Øb	Øc	N1	N2	N1/N2	N3	N4	N5	N6	N7	N8
				mm	mm	mm	mm	mm	mm	mm	mm	mm	mm	mm	mm	mm	mm	mm	mm	DN/in	DN/in	PN	DN/in	DN/in	DN/in	DN/in	DN/in	DN/in
REX 7	REX K 7	REX 7 F	REX K 7 F	1063	853	415	912	415	54,5	756	700	994	630	413	240	341	200-250	130	200	50	50	6	1"	1"	-	1/2"	1/2"	1/2"
REX 8	REX K 8	REX 8 F	REX K 8 F	1063	853	415	912	415	54,5	756	700	994	630	413	240	341	200-250	130	200	50	50	6	1"	1"	-	1/2"	1/2"	1/2"
REX 9	REX K 9	REX 9 F	REX K 9 F	1030	855	415	912	415	54,5	756	700	1119	755	513	265	341	200-250	130	200	50	50	6	1"	1"	-	1/2"	1/2"	1/2"
REX 10	REX K 10	REX 10 F	REX K 10 F	1030	855	415	912	415	54,5	756	700	1119	755	513	265	341	200-250	130	200	50	50	6	1"	1"	-	1/2"	1/2"	1/2"
REX 12	REX K 12	REX 12 F	REX K 12 F	1030	855	415	912	415	54,5	756	700	1119	755	513	265	341	200-250	130	200	50	50	6	1"	1"	-	1/2"	1/2"	1/2"
REX 15	REX K 15	REX 15 F	REX K 15 F	1080	905	440	962	440	54,5	806	750	1364	1000	513	475	376	200-250	160	250	50	50	6	1"	1"	-	1/2"	1/2"	1/2"
REX 20	REX K 20	REX 20 F	REX K 20 F	1080	905	440	962	440	54,5	806	750	1364	1000	513	475	376	200-250	160	250	50	50	6	1"	1"	-	1/2"	1/2"	1/2"
REX 25	REX K 25	REX 25 F	REX K 25 F	1080	905	440	962	440	54,5	806	750	1614	1250	513	725	376	200-250	160	250	50	50	6	1"	1"	-	1/2"	1/2"	1/2"
REX 30	REX K 30	REX 30 F	REX K 30 F	1180	1005	490	1061	490	54,5	906	850	1614	1250	513	725	391	200-250	180	250	65	65	6	1"	1"	-	1/2"	1/2"	1/2"
REX 35	REX K 35	REX 35 F	REX K 35 F	1180	1005	490	1061	490	54,5	906	850	1864	1500	523	980	361	200-250	180	250	65	65	6	1"	1"	-	1/2"	1/2"	1/2"
REX 40	REX K 40	REX 40 F	REX K 40 F	1190	1015	500	1095	500	50	946	890	1872	1502	600	850	422	230-280	225	250	80	80	6	1"	1"	1"1/4(1)	1/2"	1/2"	1/2"
REX 50	REX K 50	REX 50 F	REX K 50 F	1380	1205	610	1285	610	60	1166	1110	1946	1502	663	850	433	270-320	225	300	80	80	6	1"	1"1/4	1"1/4	1/2"	1/2"	1/2"
REX 62	REX K 62	REX 62 F	REX K 62 F	1380	1205	610	1285	610	60	1166	1110	2235	1792	663	1150	422	270-320	225	300	80	80	6	1"	1"1/4	1"1/4	1/2"	1/2"	1/2"
REX 75	REX K 75	REX 75 F	REX K 75 F	1510	1335	675	1417	675	60	1296	1240	2247	1753	704	1100	443	270-320	280	350	100	100	6	1"	1"1/4	1"1/2	1/2"	1/2"	1/2"
REX 85	REX K 85	REX 85 F	REX K 85 F	1510	1335	675	1417	675	60	1296	1240	2247	1753	704	1100	443	270-320	280	350	100	100	6	1"	1"1/4	1"1/2	1/2"	1/2"	1/2"
REX 95	REX K 95	REX 95 F	REX K 95 F	1510	1335	675	1417	675	60	1296	1240	2497	2003	704	1200	593	270-320	280	350	100	100	6	1"	1"1/4	1"1/2	1/2"	1/2"	1/2"
REX 100	REX K 100	REX 100 F	REX K 100 F	1660	1485	750	1568	750	60	1446	1390	2477	2003	703	1200	574	270-320	280	400	125	125	6	1"	1"1/4	1"1/2	1/2"	1/2"	1/2"
REX 120	REX K 120	REX 120 F	REX K 120 F	1660	1485	750	1568	750	60	1446	1390	2477	2003	703	1200	574	270-320	280	400	125	125	6	1"	1"1/4	1"1/2	1/2"	1/2"	1/2"
REX 130	REX K 130	REX 130 F	REX K 130 F	1660	1485	750	1568	750	60	1446	1390	2477	2003	703	1200	574	270-320	280	400	125	125	6	1"	1"1/4	1"1/2	1/2"	1/2"	1/2"

P6 bio-gas: +40 mm

(1) One fitting only

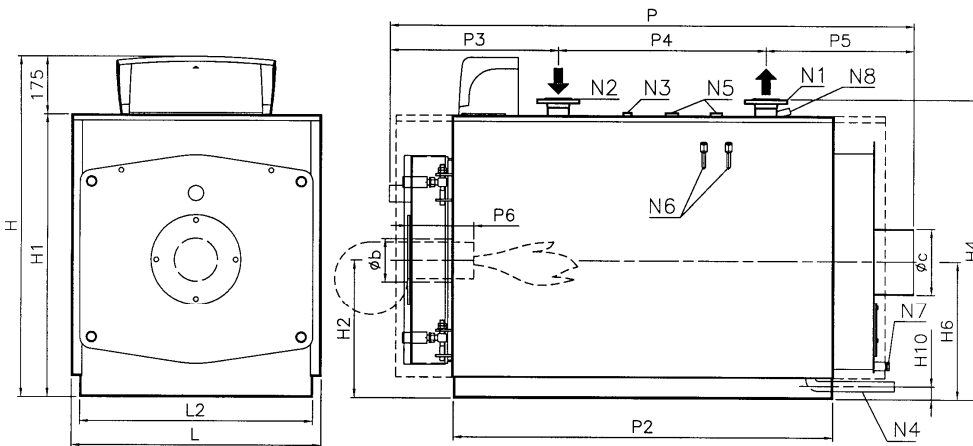

- N1 - Flow
- N2 - Return
- N3 - Fitting for instruments
- N4 - System filling/drainage
- N5 - Fitting for safety valves
- N6 - Bulb wells
- N7 - Condensation drain
- N8 - Inspection well

4.2 REX/REX K/REX F/REX K F 140-350 BOILER

Characteristics			Heat output		Heat input		Efficiency 100% (N.C.V.)	NG max flow rate G20	NG max flow rate G30	NG max flow rate G31	Max flow rate of flues	Max fluid flow	Min. fluid flow	Efficiency at 30% (N.C.V.)
			u.m.	kW	kcal/h	kW	kcal/h	%	Stm ² /h	kg/h	kg/h	kg/h	kg/h	%
			NOTE	Medium Temp. 70°C		Medium Temp. 70°C								Medium Temp. 70°C
REX 140	REX K 140	(3)	1400	1.204.000	1517	1.304.620	92,29	160,53	119,14	117,85	2391,90	120400	48160	91,70
REX 160	REX K 160	(3)	1600	1.376.000	1733	1.490.380	92,33	183,39	136,11	134,63	2732,51	137600	55040	91,80
REX 180	REX K 180	(3)	1800	1.548.000	1950	1.677.000	92,31	206,35	153,15	151,49	3074,62	154800	61920	91,80
REX 200	REX K 200		2000	1.720.000	2167	1.863.620	92,29	229,31	170,19	168,35	3416,72	172000	68800	91,70
REX 240	REX K 240		2400	2.064.000	2600	2.236.000	92,31	275,13	204,20	201,99	4099,44	206400	82560	91,80
REX 300	REX K 300		3000	2.580.000	3250	2.795.000	92,31	343,92	255,25	252,48	5124,41	258000	103200	91,80
REX 350	REX K 350		3500	3.010.000	3792	3.261.120	92,3	401,27	297,82	294,59	5978,92	301000	120400	91,70

Characteristics		Pressure losses flue gas side	Heat losses through the chimney	Heat losses through the casing	Heat losses with burner off	Flue gas temp. at boiler output and air at 20 deg. C			CO2			Press. losses fluid side	Design Pressure	Total capacity	Total weight	Electric supply	Frequency	Insulation class	Electric power	Fuel				
		mbar	%	%	%	°C			%			mbar	bar	l	kg	Volt ~	Hz	IP	W					
						GAS GASOIL HEAVY OIL			GAS GASOIL HEAVY OIL			(ΔT=12K)								With electr. contr. (excluded pump and burner)				
						°C			%												Nat. gas LPG Gasoil Heavy oil			
REX 140	REX K 140	6,0	6,91	0,80	0,10	184	187	187	10,5	13,5	14,0	38	5	1500	2600	230	50	IP40	20	X	X	X	X	
REX 160	REX K 160	6,5	6,87	0,80	0,10	183	186	186	10,5	13,5	14,0	50	5	1500	2600	230	50	IP40	20	X	X	X	X	
REX 180	REX K 180	7,0	6,89	0,80	0,10	184	186	186	10,5	13,5	14,0	63	5	1650	2750	230	50	IP40	20	X	X	X	X	
REX 200	REX K 200	6,0	6,91	0,80	0,10	184	187	187	10,5	13,5	14,0	25	5	2000	3650	230	50	IP40	20	X	X	X	X	
REX 240	REX K 240	7,5	6,89	0,80	0,10	184	186	186	10,5	13,5	14,0	35	5	2300	3900	230	50	IP40	20	X	X	X	X	
REX 300	REX K 300	8,0	6,89	0,80	0,10	184	186	186	10,5	13,5	14,0	55	5	3150	5200	230	50	IP40	20	X	X	X	X	
REX 350	REX K 350	9,0	6,90	0,80	0,10	184	187	186	10,5	13,5	14,0	75	5	3650	5700	230	50	IP40	20	X	X	X	X	

Characteristics			Heat output		Heat input		Efficiency 100% (N.C.V.)	NG max flow rate G20	NG max flow rate G30	NG max flow rate G31	Max flow rate of flues	Max fluid flow	Min. fluid flow	Efficiency at 30% (N.C.V.)
			u.m.	kW	kcal/h	kW	kcal/h	%	Stm ² /h	kg/h	kg/h	kg/h	kg/h	%
			NOTE	Medium Temp. 70°C		Medium Temp. 70°C								Medium Temp. 70°C
REX 140 F	REX K 140 F	(3)	1400	1.204.000	1468	1.262.480	95,37	155,34	115,29	114,05	2314,57	120400	48160	95,87
REX 160 F	REX K 160 F	(3)	1600	1.376.000	1675	1.440.500	95,52	177,25	131,55	130,13	2641,03	137600	55040	95,80
REX 180 F	REX K 180 F	(3)	1800	1.548.000	1885	1.621.100	95,49	199,47	148,05	146,44	2972,10	154800	61920	95,70
REX 200 F	REX K 200 F		2000	1.720.000	2094	1.800.840	95,51	221,59	164,46	162,68	3301,69	172000	68800	95,80
REX 240 F	REX K 240 F		2400	2.064.000	2518	2.165.480	95,31	266,46	197,76	195,62	3970,25	206400	82560	95,40
REX 300 F	REX K 300 F		3000	2.580.000	3142	2.702.120	95,48	332,49	246,77	244,09	4954,10	258000	103200	95,60
REX 350 F	REX K 350 F		3500	3.010.000	3670	3.156.200	95,37	388,36	288,24	285,11	5786,56	301000	120400	95,87

Characteristics		Pressure losses flue gas side	Heat losses through the chimney	Heat losses through the casing	Heat losses with burner off	Flue gas temp. at boiler output and air at 20 deg. C			CO2	Press. losses fluid side	Design Pressure	Total capacity	Total weight	Electric supply	Frequency	Insulation class	Electric power	Fuel			
		mbar	%	%	%	°C			%	mbar	bar	l	kg	Volt ~	Hz	IP	W				
						GAS GASOIL HEAVY OIL			GAS GASOIL HEAVY OIL	(ΔT=12K)								With electr. contr. (excluded pump and burner)			
						°C			%									Nat. gas LPG Gasoil Heavy oil			
REX 140 F	REX K 140 F	6,6	4,13	0,50	0,10	124	124	124	11,0	38	5	1500	2665	230	50	IP40	20	X	X	-	-
REX 160 F	REX K 160 F	7,1	3,98	0,50	0,10	120	120	120	11,0	50	5	1500	2665	230	50	IP40	20	X	X	-	-
REX 180 F	REX K 180 F	7,6	4,01	0,50	0,10	124	124	124	11,0	63	5	1650	2815	230	50	IP40	20	X	X	-	-
REX 200 F	REX K 200 F	6,6	3,99	0,50	0,10	120	120	120	11,0	25	5	2000	3730	230	50	IP40	20	X	X	-	-
REX 240 F	REX K 240 F	8,1	4,19	0,50	0,10	125	125	125	11,0	35	5	2300	3980	230	50	IP40	20	X	X	-	-
REX 300 F	REX K 300 F	8,6	4,02	0,50	0,10	121	121	121	11,0	55	5	3150	5300	230	50	IP40	20	X	X	-	-
REX 350 F	REX K 350 F	9,6	4,13	0,50	0,10	124	124	124	11,0	75	5	3650	5800	230	50	IP40	20	X	X	-	-

Dimensions				H	H1	H2	H6	H10	L	L2	P	P2	P3	P4	P5	P6	Øb	Øc	N1	N2	N1/N2	N3	N4	N5	N6	N7	N8	
				mm	mm	mm	mm	mm	mm	mm	mm	mm	mm	mm	mm	mm	mm	mm	mm	DN/in	DN/in	PN	DN/in	DN/in	DN/in	DN/in	DN/in	DN/in
REX 140	REX K 140	REX 140 F	REX K 140 F	1746	1630	880	880	150	1470	1270	2886	2300	831	1300	755	350-400	320	400	150	150	16	1"	1 1/4"	1 1/2"	1/2"	1/2"	1/2"	
REX 160	REX K 160	REX 160 F	REX K 160 F	1746	1630	880	880	150	1470	1270	2886	2300	831	1300	755	350-400	320	400	150	150	16	1"	1 1/4"	1 1/2"	1/2"	1/2"	1/2"	
REX 180	REX K 180	REX 180 F	REX K 180 F	1746	1630	880	880	150	1470	1270	3096	2510	771	1850	475	450-500	320	400	150	150	16	1"	1 1/4"	1 1/2"	1/2"	1/2"	1/2"	
REX 200	REX K 200	REX 200 F	REX K 200 F	1876	1760	945	945	150	1600	1400	3220	2510	903	1550	767	450-500	360	500	200	200	16	1"	1 1/4"	2"	1/2"	1/2"	1/2"	
REX 240	REX K 240	REX 240 F	REX K 240 F	1876	1760	945	945	150	1600	1400	3480	2770	903	1950	627	450-500	360	500	200	200	16	1"	1 1/4"	2"	1/2"	1/2"	1/2"	
REX 300	REX K 300	REX 300 F	REX K 300 F	2146	2030	1080	1080	150	1870	1670	3480	2770	903	2050	527	450-500	400	550	200	200	16	1"	1 1/4"	2"	1/2"	1/2"	1/2"	
REX 350	REX K 350	REX 350 F	REX K 350 F	2146	2030	1080	1080	150	1870	1670	3935	3225	903	2050	982	450-500	400	550	200	200	16	1"	1 1/4"	2"	1/2"	1/2"	1/2"	

(3) Door opening reversible

P6 bio-gas:+40 mm

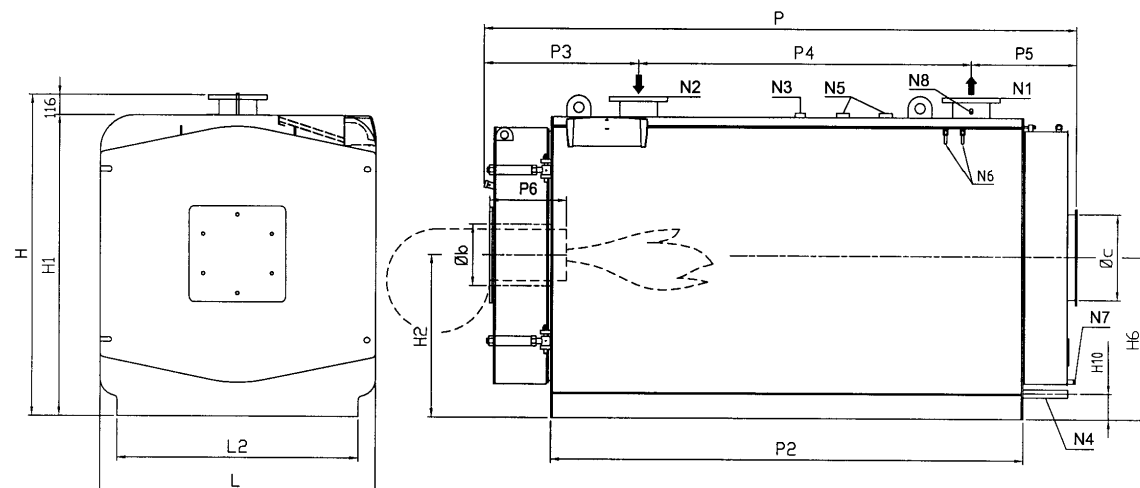

- N1 - Flow
- N2 - Return
- N3 - Fitting for instruments
- N4 - System filling/drainage
- N5 - Fitting for safety valves
- N6 - Bulb wells
- N7 - Condensation drain
- N8 - Inspection well

4.3 REX 400-600 BOILER

Characteristics	Heat output		Heat input		Efficiency 100% (N.C.V.)	NG max flow rate G20	NG max flow rate G30	NG max flow rate G31	Max flow rate of flues	Max fluid flow	Min. fluid flow	Efficiency at 30% (N.C.V.)
	kW	kcal/h	kW	kcal/h								
	Medium Temp. 70°C				Medium Temp. 70°C							Medium Temp. 70°C
REX 400	4000	3.440.000	4333	3.726.380	92,31	458,52	340,31	336,62	6831,95	344000	137600	91,80
REX 450	4500	3.870.000	4865	4.183.900	92,5	514,81	382,09	377,95	7670,67	387000	154800	91,90
REX 500	5000	4.300.000	5402	4.645.720	92,56	571,64	424,27	419,67	8517,44	430000	172000	91,90
REX 600	6000	5.160.000	6480	5.572.800	92,59	685,71	508,93	503,41	10217,08	516000	206400	91,90

Characteristics	Pressure losses flue gas side	Heat losses through the chimney	Heat losses through the casing	Heat losses with burner off	Flue gas temp. at boiler output and air at 20 deg. C			CO2			Press. losses fluid side	Design Pressure	Total capacity	Total weight	Electric supply	Frequency	Insulation class	Electric power	Fuel												
					°C			%											mbar	bar	l	kg	Volt ~	Hz	IP	W	With electr. contr. (excluded pump and burner)	Nat. gas	Lpg	Gasoil	Heavy oil
					GAS	GASOIL	HEAVY OIL	GAS	GASOIL	HEAVY OIL																					
REX 400	9,0	6,89	0,80	0,10	184	186	186	10,5	13,5	14,0	98	6	4450	7420	230	50	IP40	20	X	X	X	X									
REX 450	10,0	6,70	0,80	0,10	179	182	182	10,5	13,5	14,0	124	6	4900	7920	230	50	IP40	20	X	X	X	X									
REX 500	10,0	6,64	0,80	0,10	178	181	180	10,5	13,5	14,0	63	6	6200	9530	230	50	IP40	20	X	X	X	X									
REX 600	12,0	6,61	0,80	0,10	177	180	180	10,5	13,5	14,0	91	6	6900	11330	230	50	IP40	20	X	X	X	X									

Characteristics	Heat output		Heat input		Efficiency 100% (N.C.V.)	NG max flow rate G20	NG max flow rate G30	NG max flow rate G31	Max flow rate of flues	Max fluid flow	Min. fluid flow	Efficiency at 30% (N.C.V.)
	kW	kcal/h	kW	kcal/h								
	Medium Temp. 70°C				Medium Temp. 70°C							Medium Temp. 70°C
REX 400 F	4000	3.440.000	4195	3.607.700	95,35	443,92	329,47	325,90	6614,41	344000	137600	95,45
REX 450 F	4500	3.870.000	4720	4.059.200	95,34	499,47	370,70	366,68	7442,10	387000	154800	95,50
REX 500 F	5000	4.300.000	5245	4.510.700	95,33	555,03	411,94	407,47	8269,95	430000	172000	95,46
REX 600 F	6000	5.160.000	6295	5.413.700	95,31	666,14	494,40	489,04	9925,49	516000	206400	95,48

Characteristics	Pressure losses flue gas side	Heat losses through the chimney	Heat losses through the casing	Heat losses with burner off	Flue gas temp. at boiler output and air at 20 deg. C			CO2	Press. losses fluid side	Design Pressure	Total capacity	Total weight	Electric supply	Frequency	Insulation class	Electric power	Fuel												
					°C												mbar	bar	l	kg	Volt ~	Hz	IP	W	With electr. contr. (excluded pump and burner)	Nat. gas	Lpg	Gasoil	Heavy oil
					GAS	GASOIL	HEAVY OIL																						
REX 400 F	11,0	3,85	0,80	0,10	114	114	114	10,5	98	6	4450	7540	230	50	IP40	20	X	X	-	-									
REX 450 F	11,0	3,86	0,80	0,10	114	114	114	10,5	124	6	4900	8040	230	50	IP40	20	X	X	-	-									
REX 500 F	11,0	3,87	0,80	0,10	114	114	114	10,5	63	6	6200	9670	230	50	IP40	20	X	X	-	-									
REX 600 F	12,0	3,89	0,80	0,10	115	115	115	10,5	91	6	6900	11480	230	50	IP40	20	X	X	-	-									

Dimensions		H	H1	H2	H6	H10	L	L2	P1	P2	P3	P4	P5	P6	Øb	Øc	N1	N2	N1/N2	N3	N4	N5	N6	N7	N8
		mm	mm	mm	mm	mm	mm	mm	mm	mm	mm	mm	mm	mm	mm	mm	DN/in	DN/in	PN	DN/in	DN/in	DN/in	DN/in	DN/in	DN/in
REX 400	REX 400 F	2326	2140	1135	1135	150	1980	1780	4310	3596	1105	2200	1005	450-500	400	600	200	200	16	50	1"1/4	50	1/2"-3/4"	1/2"	1/2"
REX 450	REX 450 F	2326	2140	1135	1135	150	1980	1780	4660	3946	1105	2550	1005	500-550	400	600	200	200	16	50	1"1/4	50	1/2"-3/4"	1/2"	1/2"
REX 500	REX 500 F	2529	2340	1235	1235	150	2180	1980	4729	3948	1174	2550	1005	500-550	450	650	250	250	16	65	1"1/4	65	1/2"-3/4"	1/2"	1/2"
REX 600	REX 600 F	2529	2340	1235	1235	150	2180	1980	5261	4488	1174	3100	987	530-580	450	650	250	250	16	65	1"1/4	65	1/2"-3/4"	1/2"	1/2"

P6 bio-gas: +40 mm P

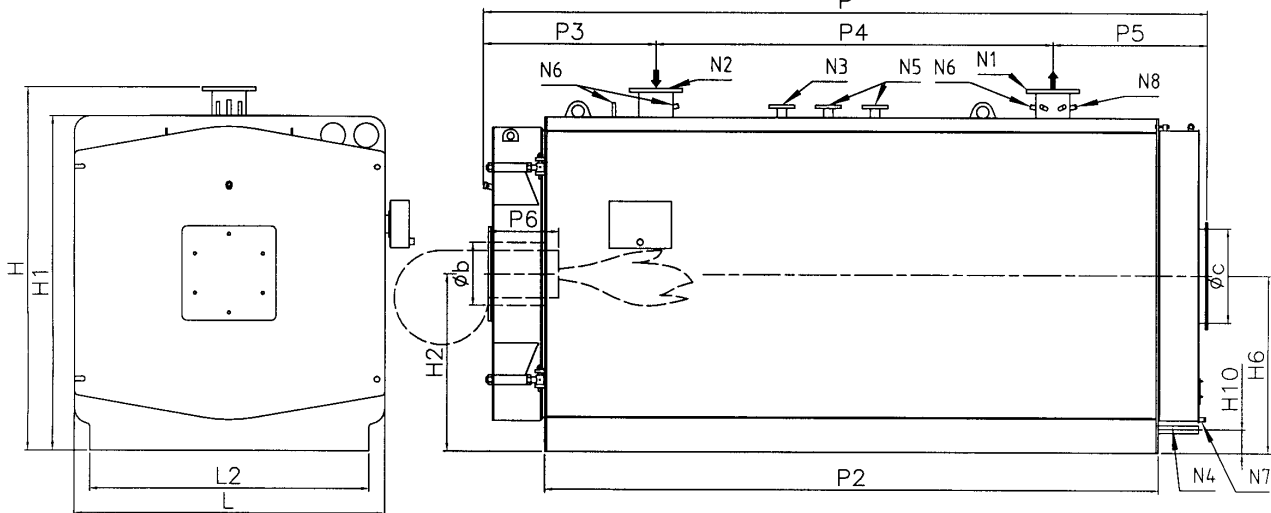

- N1 - Flow
- N2 - Return
- N3 - Fitting for instruments
- N4 - System filling/drainage

- N5 - Fitting for safety valves
- N6 - Bulb wells
- N7 - Condensation drain
- N8 - Inspection well

4.4 REX DUAL/REX DUAL F (staked) 14-170 BOILER

Characteristics	u.m.	Heat output		Heat input		Efficiency 100%	Effic. 100%	NG max flow	NG max flow	NG max flow	Max flow rate	Max fluid	Min. fluid	Efficiency at 30%
		kW	kcal/h	kW	kcal/h	(N.C.V.)	(stars)	rate G20	rate G30	rate G31	of flues	flow	flow	(N.C.V.)
		Medium Temp. 70°C				%	%	Stm ³ /h	kg/h	kg/h	kg/h	kg/h	kg/h	kg/h
	NOTE	Medium Temp. 70°C				Medium Temp. 70°C	(Efficiency Dir. 92/42/CEE)							Medium Temp. 70°C
REX DUAL 14	(3)	140	120.000	152	130.720	92,11	**	16,08	11,94	11,81	239,59	12000	4800	91,40
REX DUAL 16	(3)	160	138.000	174	149.640	91,95	**	18,41	13,67	13,52	274,31	13800	5520	91,50
REX DUAL 18	(3)	180	155.000	196	168.560	91,84	**	20,74	15,39	15,23	309,03	15500	6200	91,55
REX DUAL 20	(3)	200	172.000	218	187.480	91,74	**	23,07	17,12	16,94	343,74	17200	6880	91,66
REX DUAL 24	(3)	240	206.000	260	223.600	92,31	**	27,51	20,42	20,20	409,90	20600	8240	91,45
REX DUAL 30	(3)	300	258.000	326	280.360	92,02	**	34,50	25,60	25,33	514,05	25800	10320	91,30
REX DUAL 40	(3)	420	361.000	455	391.008	92,38	-	48,11	35,71	35,32	716,84	36100	14440	91,36
REX DUAL 50	(3)	500	430.000	542	466.120	92,25	-	57,35	42,57	42,11	854,52	43000	17200	91,70
REX DUAL 60	(3)	600	516.000	650	559.000	92,31	-	68,78	51,05	50,50	1024,82	51600	20640	91,90
REX DUAL 70	(3)	700	602.000	758	651.880	92,35	-	80,21	59,53	58,89	1195,13	60200	24080	91,90
REX DUAL 80	(3)	840	722.000	909	781.981	92,38	-	96,22	71,41	70,64	1433,68	72200	28880	91,80
REX DUAL 100	(3)	1000	860.000	1084	932.240	92,25	-	114,71	85,14	84,21	1709,18	86000	34400	91,90
REX DUAL 124	(3)	1240	1.066.000	1344	1.155.840	92,26	-	142,22	105,56	104,41	2119,08	106600	42640	91,80
REX DUAL 150	(3)	1500	1.290.000	1626	1.398.360	92,25	-	172,06	127,70	126,32	2563,69	129000	51600	91,80
REX DUAL 170	(3)	1700	1.462.000	1842	1.584.120	92,29	-	194,92	144,67	143,10	2904,31	146200	58480	91,80

Characteristics	Pressure losses flue gas side	Heat losses through the chimney	Heat losses through the casing	Heat losses with burner off	Flue gas temp. at boiler output and air at 20 deg. C			CO2			Press. losses fluid side	Design Pressure	Total capacity	Total weight	Electric supply	Frequency	Insulation class	Electric power	Fuel											
					°C		%	%	%	mbar									bar	l	kg	Volt ~	Hz	IP	W	With electr. contr. (excluded pump and burner)	Nat. gas	LPG	Gasoil	Heavy oil
					GAS	GASOIL	HEAVY OIL	GAS	GASOIL																					
REX DUAL 14	0,8	7,09	0,80	0,10	188	191	191	10,5	13,5	14,0	11	5	210	465	230	50	IP40	20	X	X	X	X								
REX DUAL 16	1,0	7,25	0,80	0,10	192	195	194	10,5	13,5	14,0	14	5	210	465	230	50	IP40	20	X	X	X	X								
REX DUAL 18	0,8	7,36	0,80	0,10	194	197	197	10,5	13,5	14,0	18	5	246	549	230	50	IP40	20	X	X	X	X								
REX DUAL 20	1,0	7,46	0,80	0,10	197	199	199	10,5	13,5	14,0	22	5	246	549	230	50	IP40	20	X	X	X	X								
REX DUAL 24	1,1	6,89	0,80	0,10	184	186	186	10,5	13,5	14,0	32	5	246	549	230	50	IP40	20	X	X	X	X								
REX DUAL 30	1,2	7,18	0,80	0,10	190	193	193	10,5	13,5	14,0	22	5	344	726	230	50	IP40	20	X	X	X	X								
REX DUAL 40	2,1	6,82	0,80	0,10	182	185	184	10,5	13,5	14,0	42	5	344	726	230	50	IP40	20	X	X	X	X								
REX DUAL 50	2,0	6,95	0,80	0,10	185	188	187	10,5	13,5	14,0	60	5	440	898	230	50	IP40	20	X	X	X	X								
REX DUAL 60	2,0	6,89	0,80	0,10	184	186	186	10,5	13,5	14,0	86	5	600	986	230	50	IP40	20	X	X	X	X								
REX DUAL 70	2,9	6,85	0,80	0,10	183	186	185	10,5	13,5	14,0	118	5	712	1122	230	50	IP40	20	X	X	X	X								
REX DUAL 80	4,5	6,82	0,80	0,10	182	185	184	10,5	13,5	14,0	69	5	720	1285	230	50	IP40	20	X	X	X	X								
REX DUAL 100	4,2	6,95	0,80	0,10	185	188	187	10,5	13,5	14,0	98	5	1080	1830	230	50	IP40	20	X	X	X	X								
REX DUAL 124	6,4	6,94	0,80	0,10	185	188	187	10,5	13,5	14,0	62	5	1290	2065	230	50	IP40	20	X	X	X	X								
REX DUAL 150	5,2	6,95	0,80	0,10	185	188	187	10,5	13,5	14,0	44	5	1710	2621	230	50	IP40	20	X	X	X	X								
REX DUAL 170	7,2	6,91	0,80	0,10	184	187	187	10,5	13,5	14,0	56	5	1710	2621	230	50	IP40	20	X	X	X	X								

Characteristics	u.m.	Heat output		Heat input		Efficiency 100%	Effic. 100%	NG max flow	NG max flow	NG max flow	Max flow rate	Max fluid	Min. fluid	Efficiency at 30%
		kW	kcal/h	kW	kcal/h	(N.C.V.)	(stars)	rate G20	rate G30	rate G31	of flues	flow	flow	(N.C.V.)
		Medium Temp. 70°C				%	%	Stm ³ /h	kg/h	kg/h	kg/h	kg/h	kg/h	kg/h
	NOTE	Medium Temp. 70°C				Medium Temp. 70°C	(Efficiency Dir. 92/42/CEE)							Medium Temp. 70°C
REX DUAL 14 F	(3)	140	120.000	148	127.624	94,34	***	15,70	11,66	11,53	233,93	12000	4800	94,80
REX DUAL 16 F	(3)	160	138.000	169	145.684	94,45	***	17,93	13,30	13,16	267,16	13800	5520	94,70
REX DUAL 18 F	(3)	180	155.000	190	163.744	94,54	***	20,15	14,95	14,79	300,24	15500	6200	95,00
REX DUAL 20 F	(3)	200	172.000	211	181.632	94,70	***	22,35	16,59	16,41	333,02	17200	6880	94,80
REX DUAL 24 F	(3)	240	206.000	253	217.580	94,86	***	26,77	19,87	19,65	398,87	20600	8240	95,10
REX DUAL 30 F	(3)	300	258.000	316	271.416	95,06	***	33,40	24,79	24,52	497,66	25800	10320	95,70
REX DUAL 40 F	(3)	420	361.000	441	379.260	95,24	-	46,67	34,64	34,26	695,38	36100	14440	95,30
REX DUAL 50 F	(3)	500	430.000	527	453.220	94,88	-	55,77	41,39	40,94	830,97	43000	17200	95,38
REX DUAL 60 F	(3)	600	516.000	631	542.660	95,09	-	66,77	49,56	49,02	994,87	51600	20640	95,59
REX DUAL 70 F	(3)	700	602.000	734	631.240	95,37	-	77,67	57,65	57,02	1157,28	60200	24080	95,60
REX DUAL 80 F	(3)	840	722.000	926	796.472	90,7	-	98,00	72,74	71,95	1460,20	72200	28880	95,40
REX DUAL 100 F	(3)	1000	860.000	1048	901.280	95,42	-	110,90	82,31	81,42	1652,41	86000	34400	95,70
REX DUAL 124 F	(3)	1240	1.066.000	1298	1.116.280	95,53	-	137,35	101,94	100,84	2046,52	106600	42640	95,90
REX DUAL 150 F	(3)	1500	1.290.000	1572	1.351.920	95,42	-	166,35	123,46	122,12	2478,62	129000	51600	95,92
REX DUAL 170 F	(3)	1700	1.462.000	1782	1.532.520	95,40	-	188,57	139,96	138,44	2809,69	146200	58480	95,80

Characteristics	Pressure losses flue gas side	Heat losses through the chimney	Heat losses through the casing	Heat losses with burner off	Flue gas temp. at boiler output and air at 20 deg. C		CO2	Press. losses fluid side	Design Pressure	Total capacity	Total weight	Electric supply	Frequency	Insulation class	Electric power	Fuel													
					°C											%	mbar	bar	l	kg	Volt ~	Hz	IP	W	With electr. contr. (excluded pump and burner)	Nat. gas	LPG	Gasoil	Heavy oil
					GAS	GASOIL										(ΔT=12K)													
REX DUAL 14 F	0,9	5,16	0,50	0,10	148	148	11,0	11	5	210	477	230	50	IP40	20	X	X	-	-										
REX DUAL 16 F	1,1	5,05	0,50	0,10	146	146	11,0	14	5	210	477	230	50	IP40	20	X	X	-	-										
REX DUAL 18 F	0,9	4,96	0,50	0,10	143	143	11,0	18	5	246	565	230	50	IP40	20	X	X	-	-										
REX DUAL 20 F	1,1	4,80	0,50	0,10	140	140	11,0	22	5	246	565	230	50	IP40	20	X	X	-	-										
REX DUAL 24 F	1,3	4,64	0,50	0,10	136	136	11,0	32	5	246	565	230	50	IP40	20	X	X	-	-										
REX DUAL 30 F	1,3	4,44	0,50	0,10	131	131	11,0	22	5	344	748	230	50	IP40	20	X	X	-	-										
REX DUAL 40 F	2,4	4,26	0,50	0,10	127	127	11,0	42	5	344	748	230	50	IP40	20	X	X	-	-										
REX DUAL 50 F	2,4	4,62	0,50	0,10	135	135	11,0	60	5	440	920	230	50	IP40	20	X	X	-	-										
REX DUAL 60 F	2,4	4,41	0,50	0,10	130	130	11,0	86	5	600	1014	230	50	IP40	20	X	X	-	-										
REX DUAL 70 F	3,4	4,13	0,50	0,10	124	124	11,0	118	5	712	1154	230	50	IP40	20	X	X	-	-										
REX DUAL 80 F	5,2	8,80	0,50	0,10	235	235	11,0	69	5	720	1317	230	50	IP40	20	X	X	-	-										
REX DUAL 100 F	4,8	4,08	0,50	0,10	122	122	11,0																						

Dimensions		H	H1	H2	H3	H4	H6	H7	H8	H10	H11	L	L1	L2	L4	P	P2	P3	P4	P6	Øb	Øc	N1/N2	N1	N2	N3	N4	N5	N6	N7	N8
		mm	mm	mm	mm	mm	mm	mm	mm	mm	mm	mm	mm	mm	mm	mm	mm	mm	mm	mm	mm	mm	mm	PN	DN/in	DN/in	DN/in	DN/in	DN/in	DN/in	DN/in
REX DUAL 14	REX DUAL 14 F	1693	-	415	1245	1610	415	1245	780	54,5	884,5	939	756	700	540	1365	630	996	369	200-250	130	200	6	65	65	1"	1"	1"	1/2"	1/2"	1/2"
REX DUAL 16	REX DUAL 16 F	1693	-	415	1245	1610	415	1245	780	54,5	884,5	939	756	700	540	1365	630	996	369	200-250	130	200	6	65	65	1"	1"	1"	1/2"	1/2"	1/2"
REX DUAL 18	REX DUAL 18 F	1693	-	415	1245	1610	415	1245	780	54,5	884,5	939	756	700	540	1490	755	1121	369	200-250	130	200	6	65	65	1"	1"	1"	1/2"	1/2"	1/2"
REX DUAL 20	REX DUAL 20 F	1693	-	415	1245	1610	415	1245	780	54,5	884,5	939	756	700	540	1490	755	1121	369	200-250	130	200	6	65	65	1"	1"	1"	1/2"	1/2"	1/2"
REX DUAL 24	REX DUAL 24 F	1693	-	415	1245	1610	415	1245	780	54,5	884,5	939	756	700	540	1490	755	1121	369	200-250	130	200	6	65	65	1"	1"	1"	1/2"	1/2"	1/2"
REX DUAL 30	REX DUAL 30 F	1793	-	440	1320	1710	440	1320	830	54,5	934,5	989	806	750	590	1798	1000	1400	398	200-250	160	250	6	80	80	1"	1"	1"	1/2"	1/2"	1/2"
REX DUAL 40	REX DUAL 40 F	1793	-	440	1320	1710	440	1320	830	54,5	934,5	989	806	750	590	1798	1000	1400	398	200-250	160	250	6	80	80	1"	1"	1"	1/2"	1/2"	1/2"
REX DUAL 50	REX DUAL 50 F	1793	-	440	1320	1710	440	1320	830	54,5	1034,5	989	806	750	590	2048	1250	1650	398	200-250	160	250	6	80	80	1"	1"	1"	1/2"	1/2"	1/2"
REX DUAL 60	REX DUAL 60 F	1993	-	490	1470	1910	490	1470	930	54,5	1034,5	1089	906	850	690	2049	1250	1651	398	200-250	180	250	6	80	80	1"	1"	1"	1/2"	1/2"	1/2"
REX DUAL 70	REX DUAL 70 F	1993	-	490	1470	1910	490	1470	930	54,5	1034,5	1089	906	850	690	2299	1500	1901	398	200-250	180	250	6	80	80	1"	1"	1"	1/2"	1/2"	1/2"
REX DUAL 80	REX DUAL 80 F	2244	2040	500	1525	2139	500	1525	1069	50	1075	1129	946	890	720	2440	1502	1795	645	230-280	225	250	6	100	100	1"	1"	1"1/4(1)+1"1/2(2)	1/2"	1/2"	1/2"
REX DUAL 100	REX DUAL 100 F	2624	2420	610	1825	2520	610	1825	1259	60	1275	1349	1166	1110	900	2490	1502	1847	643	270-320	225	300	6	100	100	1"	1"1/4	1"1/4+1"1/2(2)	1/2"	1/2"	1/2"
REX DUAL 124	REX DUAL 124 F	2640	2420	610	1825	2520	610	1825	1259	60	1275	1349	1166	1110	900	2792	1792	2113	679	270-320	225	300	6	125	125	1"	1"1/4	1"1/4+1"1/2(2)	1/2"	1/2"	1/2"
REX DUAL 150	REX DUAL 150 F	2935	2680	675	2020	2793	675	2020	1372	60	1405	1479	1296	1240	1000	2756	1753	2087	668	270-320	280	350	6	150	150	1"	1"1/4	1"1/2+1"1/2(2)	1/2"	1/2"	1/2"
REX DUAL 170	REX DUAL 170 F	2935	2680	675	2020	2793	675	2020	1372	60	1405	1479	1296	1240	1000	2756	1753	2087	668	270-320	280	350	6	150	150	1"	1"1/4	1"1/2+1"1/2(2)	1/2"	1/2"	1/2"

P6 bio-gas:+40 mm

- (1) One fitting only
- (2) Upon flow pipe

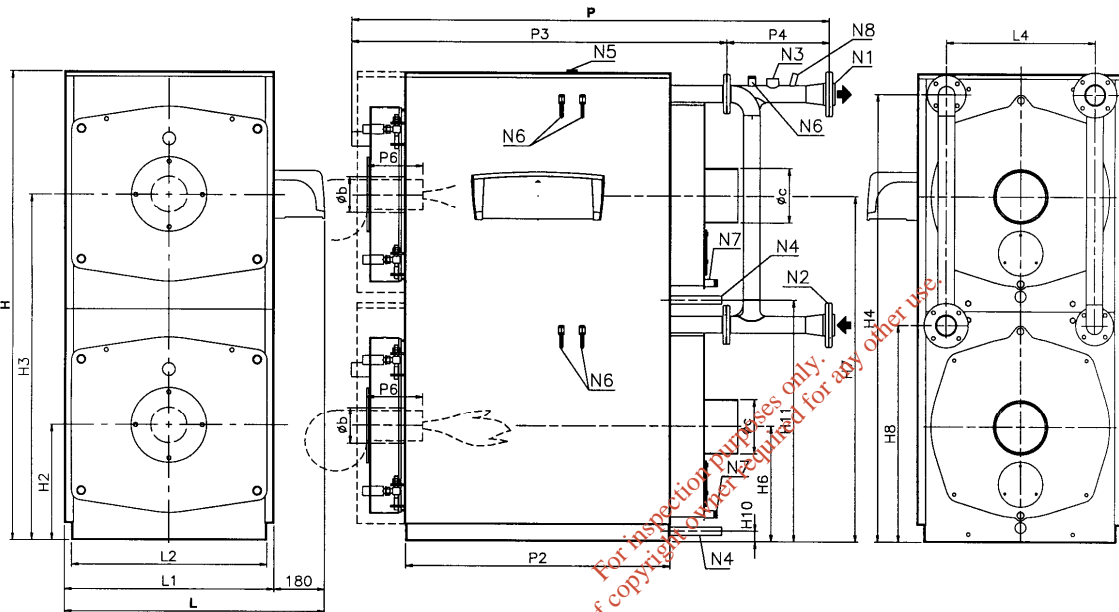

Mod 14-70

- N1 - Flow
- N2 - Return
- N3 - Fitting for instruments
- N4 - System filling/drainage
- N5 - Fitting for safety valves
- N6 - Bulb wells
- N7 - Condensation drain
- N8 - Inspection well

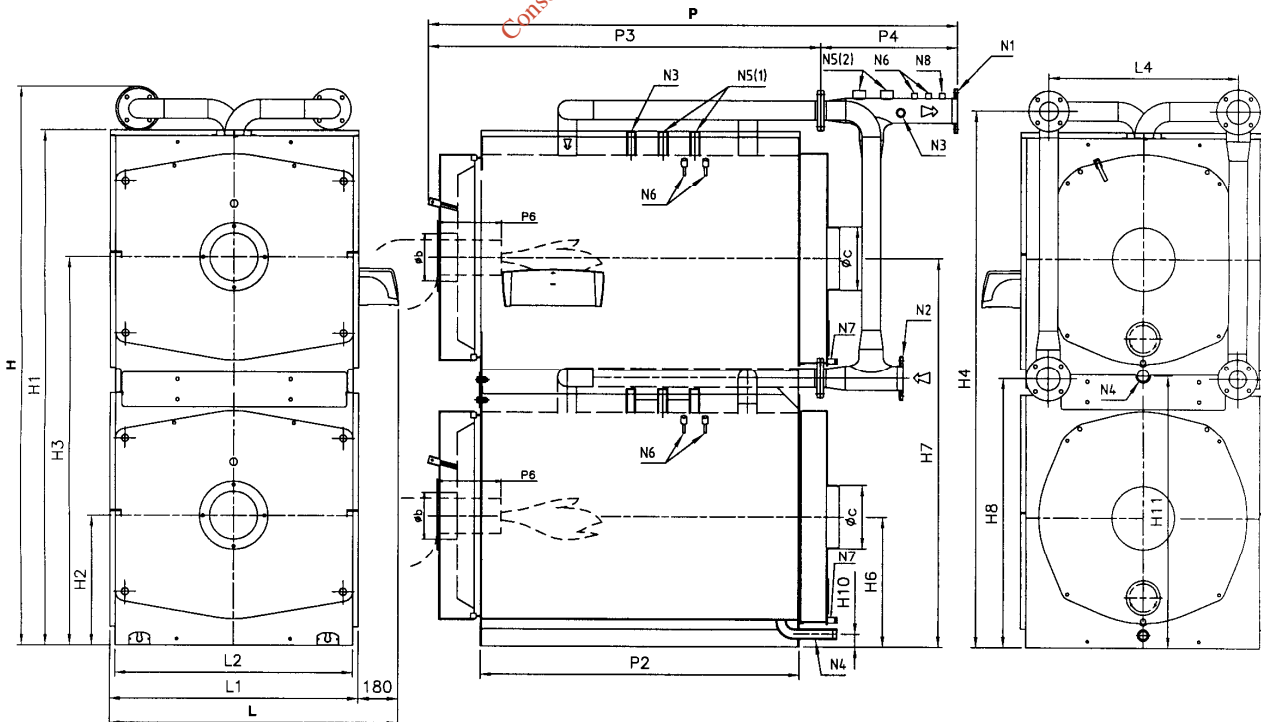

Mod. 80-170

4.5 REX DUAL/REX DUAL F (side by side) 80-260 BOILER

Characteristics	u.m.	Heat output		Heat input		Efficiency 100% (N.C.V.)	NG max flow rate G20	NG max flow rate G30	NG max flow rate G31	Max flow rate of flues	Max fluid flow	Min. fluid flow	Efficiency at 30% (N.C.V.)
		kW	kcal/h	kW	kcal/h	%	Stm ³ /h	kg/h	kg/h	kg/h	kg/h	kg/h	kg/h
	NOTE	Medium Temp. 70°C				Medium Temp. 70°C							Medium Temp. 70°C
REX DUAL 80	(3)	840	722.000	909	781.981	92,38	96,22	71,41	70,64	1433,68	72200	28880	91,80
REX DUAL 100	(3)	1000	860.000	1084	932.240	92,25	114,71	85,14	84,21	1709,18	86000	34400	91,90
REX DUAL 124	(3)	1240	1.066.000	1344	1.155.840	92,26	142,22	105,56	104,41	2119,08	106600	42640	91,80
REX DUAL 150	(3)	1500	1.290.000	1626	1.398.360	92,25	172,06	127,70	126,32	2563,69	129000	51600	91,80
REX DUAL 170	(3)	1700	1.462.000	1842	1.584.120	92,29	194,92	144,67	143,10	2904,31	146200	58480	91,80
REX DUAL 190	(3)	1900	1.634.000	2060	1.771.600	92,23	217,99	161,79	160,04	3248,05	163400	65360	91,70
REX DUAL 200	(3)	2040	1.754.000	2212	1.902.320	92,22	234,07	173,73	171,84	3487,64	175400	70160	91,70
REX DUAL 240	(3)	2400	2.064.000	2602	2.237.720	92,24	275,34	204,36	202,14	4102,57	206400	82560	91,80
REX DUAL 260	(3)	2600	2.236.000	2818	2.423.480	92,26	298,20	221,32	218,92	4443,18	223600	89440	91,70

Characteristics	Pressure losses flue gas side mbar	Heat losses through the chimney %	Heat losses through the casing %	Heat losses with burner off %	Flue gas temp. at boiler output and air at 20 deg. C			CO2			Press. losses fluid side mbar	Design Pressure bar	Total capacity l	Total weight kg	Electric supply Volt ~	Frequency Hz	Insulation class IP	Electric power W	Fuel				
					°C			%	%	%									With electr. contr. (excluded pump and burner)	Nat. gas	Lpg	Gasoil	Heavy oil
					GAS	GASOIL	HEAVY OIL	GAS	GASOIL	HEAVY OIL													
REX DUAL 80	4,5	6,82	0,80	0,10	182	185	184	10,5	13,5	14,0	69	5	720	1167	230	50	IP40	20	X	X	X	X	
REX DUAL 100	4,2	6,95	0,80	0,10	185	188	187	10,5	13,5	14,0	98	5	1080	1705	230	50	IP40	20	X	X	X	X	
REX DUAL 124	6,4	6,94	0,80	0,10	185	188	187	10,5	13,5	14,0	62	5	1290	1925	230	50	IP40	20	X	X	X	X	
REX DUAL 150	5,2	6,95	0,80	0,10	185	188	187	10,5	13,5	14,0	44	5	1710	2409	230	50	IP40	20	X	X	X	X	
REX DUAL 170	7,2	6,91	0,80	0,10	184	187	187	10,5	13,5	14,0	56	5	1710	2409	230	50	IP40	20	X	X	X	X	
REX DUAL 190	5,2	6,97	0,80	0,10	185	188	188	10,5	13,5	14,0	22	5	1900	2833	230	50	IP40	20	X	X	X	X	
REX DUAL 200	4,0	6,98	0,80	0,10	186	189	188	10,5	13,5	14,0	26	5	2400	3686	230	50	IP40	20	X	X	X	X	
REX DUAL 240	5,5	6,96	0,80	0,10	185	188	188	10,5	13,5	14,0	35	5	2400	3686	230	50	IP40	20	X	X	X	X	
REX DUAL 260	6,5	6,94	0,80	0,10	185	188	187	10,5	13,5	14,0	42	5	2400	3686	230	50	IP40	20	X	X	X	X	

Characteristics	u.m.	Heat output		Heat input		Efficiency 100% (N.C.V.)	NG max flow rate G20	NG max flow rate G30	NG max flow rate G31	Max flow rate of flues	Max fluid flow	Min. fluid flow	Efficiency at 30% (N.C.V.)
		kW	kcal/h	kW	kcal/h	%	Stm ³ /h	kg/h	kg/h	kg/h	kg/h	kg/h	kg/h
	NOTE	Medium Temp. 70°C				Medium Temp. 70°C							Medium Temp. 70°C
REX DUAL 80 F	(3)	840	722.000	926	796.472	90,7	98,00	72,74	71,95	1460,20	72200	28880	95,40
REX DUAL 100 F	(3)	1000	860.000	1048	901.280	95,42	110,90	82,31	81,42	1652,41	86000	34400	95,70
REX DUAL 124 F	(3)	1240	1.066.000	1298	1.116.280	95,53	137,35	101,94	100,84	2046,52	106600	42640	95,90
REX DUAL 150 F	(3)	1500	1.290.000	1572	1.351.920	95,42	166,35	123,46	122,12	2478,62	129000	51600	95,92
REX DUAL 170 F	(3)	1700	1.462.000	1782	1.532.520	95,40	188,57	139,96	138,44	2809,69	146200	58480	95,80
REX DUAL 190 F	(3)	1900	1.634.000	1994	1.714.840	95,29	211,01	156,61	154,91	3144,05	163400	65360	95,70
REX DUAL 200 F	(3)	2040	1.754.000	2138	1.838.680	95,42	226,24	167,92	166,10	3370,98	175400	70160	95,75
REX DUAL 240 F	(3)	2400	2.064.000	2518	2.165.480	95,31	266,46	197,76	195,62	3970,25	206400	82560	95,85
REX DUAL 260 F	(3)	2600	2.236.000	2728	2.346.080	95,31	288,68	214,25	211,93	4301,33	223600	89440	95,78

Characteristics	Pressure losses flue gas side mbar	Heat losses through the chimney %	Heat losses through the casing %	Heat losses with burner off %	Flue gas temp. at boiler output and air at 20 deg. C			CO2 %	Press. losses fluid side mbar	Design Pressure bar	Total capacity l	Total weight kg	Electric supply Volt ~	Frequency Hz	Insulation class IP	Electric power W	Fuel				
					°C												With electr. contr. (excluded pump and burner)	Nat. gas	Lpg	Gasoil	Heavy oil
					GAS	GASOIL	HEAVY OIL														
REX DUAL 80 F	5,2	8,80	0,50	0,10	235	235	235	11,0	69	5	720	1255	230	50	IP40	20	X	X	-	-	
REX DUAL 100 F	4,8	4,08	0,50	0,10	122	122	122	11,0	98	5	1080	1802	230	50	IP40	20	X	X	-	-	
REX DUAL 124 F	7,3	3,97	0,50	0,10	120	120	120	11,0	62	5	1290	2033	230	50	IP40	20	X	X	-	-	
REX DUAL 150 F	5,8	4,08	0,50	0,10	122	122	122	11,0	44	5	1710	2566	230	50	IP40	20	X	X	-	-	
REX DUAL 170 F	8,0	4,10	0,50	0,10	123	123	123	11,0	56	5	1710	2566	230	50	IP40	20	X	X	-	-	
REX DUAL 190 F	5,9	4,21	0,50	0,10	126	126	126	11,0	22	5	1900	2998	230	50	IP40	20	X	X	-	-	
REX DUAL 200 F	4,5	4,08	0,50	0,10	122	122	122	11,0	26	5	2400	3905	230	50	IP40	20	X	X	-	-	
REX DUAL 240 F	6,2	4,19	0,50	0,10	125	125	125	11,0	35	5	2400	3905	230	50	IP40	20	X	X	-	-	
REX DUAL 260 F	7,3	4,19	0,50	0,10	125	125	125	11,0	42	5	2400	3905	230	50	IP40	20	X	X	-	-	

(3) Door opening reversible

Dimensions		H	H1	H2	H4	H6	H10	L	L2	L4	P	P2	P3	P4	P5	P6	Øb	Øc	N1	N2	N1/N2	N3	N4	N5	N6	N7	N8
		mm	mm	mm	mm	mm	mm	mm	mm	mm	mm	mm	mm	mm	mm	mm	mm	mm	mm	DN/in	DN/in	PN	DN/in	DN/in	DN/in	DN/in	DN/in
REX DUAL 80	REX DUAL 80 F	1690	1015	500	1095	500	50	1901	890	955	1872	1502	600	850	422	230-280	225	250	100	100	6	1"	1"	1"1/4(1)	1/2"	1/2"	1/2"
REX DUAL 100	REX DUAL 100 F	1880	1205	610	1285	610	60	2341	1110	1175	1946	1502	663	850	433	270-320	225	300	100	100	6	1"	1"1/4	1"1/4	1/2"	1/2"	1/2"
REX DUAL 124	REX DUAL 124 F	1902	1205	610	1285	610	60	2341	1110	1175	2235	1792	663	1150	422	270-320	225	300	125	125	6	1"	1"1/4	1"1/4	1/2"	1/2"	1/2"
REX DUAL 150	REX DUAL 150 F	1990	1335	675	1417	675	60	2600	1240	1305	2247	1753	704	1100	443	270-320	280	350	150	150	6	1"	1"1/4	1"1/2	1/2"	1/2"	1/2"
REX DUAL 170	REX DUAL 170 F	1990	1335	675	1417	675	60	2600	1240	1305	2247	1753	704	1100	443	270-320	280	350	150	150	6	1"	1"1/4	1"1/2	1/2"	1/2"	1/2"
REX DUAL 190	REX DUAL 190 F	1990	1335	675	1417	675	60	2600	1240	1305	2497	2003	704	1200	593	270-320	280	350	200	200	6	1"	1"1/4	1"1/2	1/2"	1/2"	1/2"
REX DUAL 200	REX DUAL 200 F	2025	1485	750	1568	750	60	2900	1390	1455	2477	2003	703	1200	574	270-320	280	400	200	200	6	1"	1"1/4	1"1/2	1/2"	1/2"	1/2"
REX DUAL 240	REX DUAL 240 F	2025	1485	750	1568	750	60	2900	1390	1455	2477	2003	703	1200	574	270-320	280	400	200	200	6	1"	1"1/4	1"1/2	1/2"	1/2"	1/2"
REX DUAL 260	REX DUAL 260 F	2025	1485	750	1568	750	60	2900	1390	1455	2477	2003	703	1200	574	270-320	280	400	200	200	6	1"	1"1/4	1"1/2	1/2"	1/2"	1/2"

P6 bio-gas: +40 mm

⁽¹⁾ One fitting only

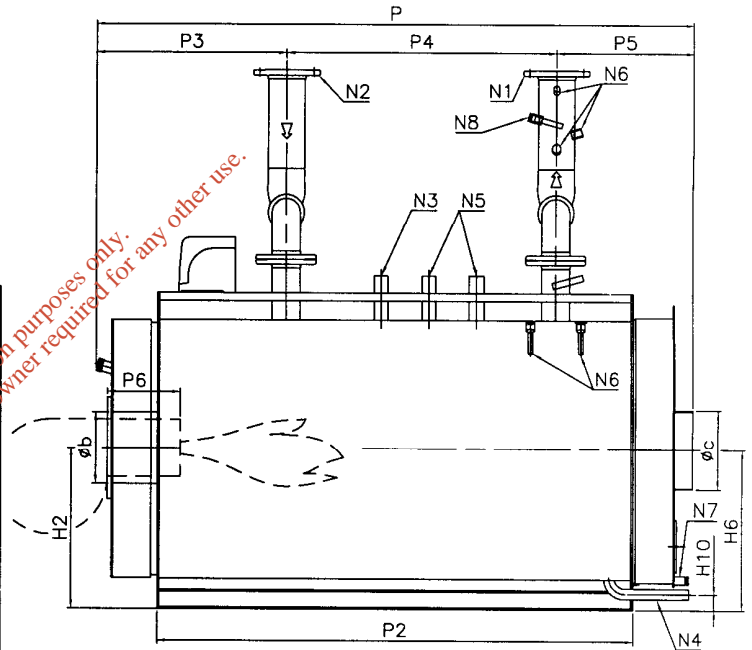
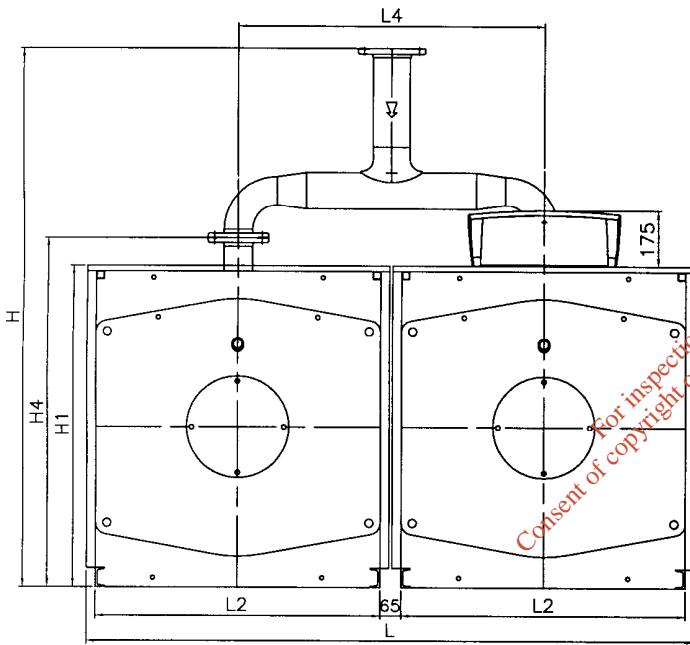

For inspection purposes only.
Consent of copyright owner required for any other use.

- N1 - Flow
- N2 - Return
- N3 - Fitting for instruments
- N4 - System filling/drainage
- N5 - Fitting for safety valves
- N6 - Bulb wells
- N7 - Condensation drain
- N8 - Inspection well

5 INSTALLATION

Before **connecting** the boiler, perform the following operations:

- Thoroughly clean all the **system pipes** in order to remove any foreign matter that could affect correct operation of the boiler;
- Check that the **flue** has an **adequate draught**, that there is no narrowing of passages and that it is free from debris; also check that other appliances do not discharge into the flue (unless designed to serve several utilities).

See the regulations in force.

5.1 THERMAL PLANT

5.1.1 BOILER ROOM

As a rule, regulations in force should be always observed. Premises in which boilers will be installed should be sufficiently ventilated and guarantee access for ordinary and extraordinary maintenance operations.

5.1.2 FLUE

The smokestack must be dimensioned as to applicable regulations.

*For inspection purposes only.
Consent of copyright owner required for any other use.*

5.2 HYDRAULIC CONNECTION

5.2.1 HOT WATER HEATING SYSTEM WITH CLOSED EXPANSION VESSEL - Furnace output ≤ 348 kW

The generator must be provided with:

- a - Safety valve
- b - Expansion vessel (connected with a hose ≥ 18 mm diameter)
- c - Regulation thermostats
- d - Safety thermostat
- e - Cut-off pressure switch
- f - Well for control thermometer
- g - Pressure gauge with flange for control pressure gauge
- h - Heat discharge valve or fuel on-off valve.
- N1 - Flow
- N2 - Return
- N3 - Instrument fitting
- N4 - Lower fitting:
 - N4b expansion vessel fitting
 - N4c filling/drain
- N6 - Bulb wells (thermometer, pump consent thermostat, regulation thermostat, safety thermostat).

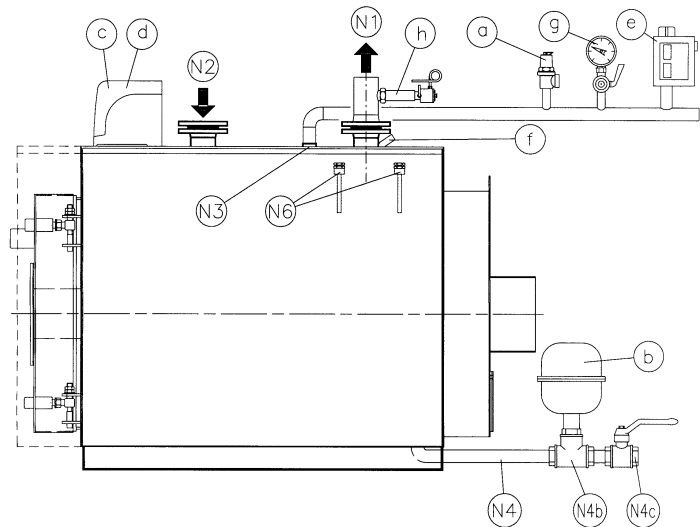

5.2.2 HOT WATER HEATING SYSTEM WITH CLOSED EXPANSION VESSEL - Furnace output > 300,000 kcal/h

The generator must be provided with:

- a - 1 safety valve
- 2 safety valves if output is > 500,000 kcal/h
- b - Expansion vessel
- c - Regulation thermostats
- d - 1st safety thermostat
- f - Cut-off pressure switch
- g - Well for control thermometer
- h - Pressure gauge with flange for control pressure gauge
- i - Heat discharge valve or fuel on-off valve
- N1 - Flow
- N2 - Return
- N3 - Instrument fitting
- N4 - Lower fitting:
 - N4b expansion vessel fitting
 - N4c Filling/drain
- N5 - Safety valves fitting
- N6 - Bulb wells (thermometer, pump consent thermostat, regulation thermostat, safety thermostat)

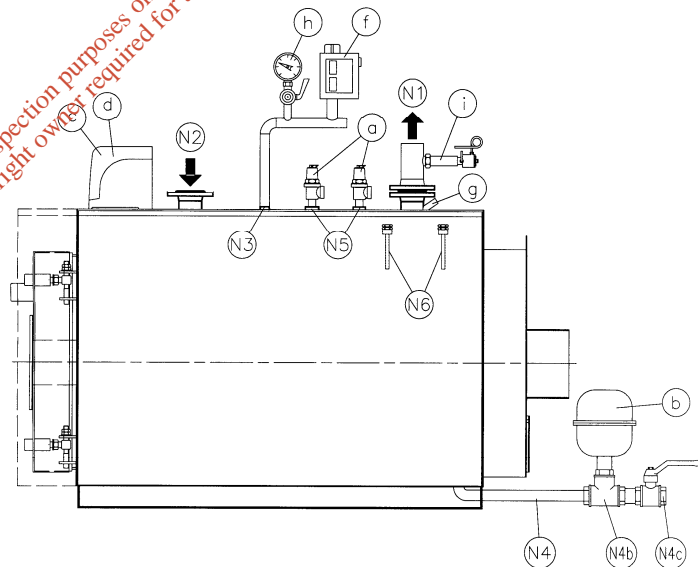

Ensure that the hydraulic pressure measured after the reduction valve on the supply pipe does not exceed the operating **pressure specified on the rating plate of the component** (boiler, heater etc.).

- As the water contained in the heating system increases in pressure during operation, ensure that its maximum value does not exceed the maximum hydraulic pressure specified on the component rating plate.
- Ensure that the safety valve outlets of the boiler and hot water tank, if any, have been connected to an exhaust funnel in order to prevent the valves from **flooding the room** if they open.
- Ensure that the pipes of the water and heating system **are not used as an earth connection** for the electrical system as this can seriously and very rapidly damage the pipes, boiler, heater and radiators.
- Once the heating system has been filled, you are advised to close the supply cock and keep it closed so that **any leaks from the system** will be identified by a drop in hydraulic pressure indicated on the system pressure gauge.

5.2.3 REX DUAL/REX DUAL F (side by side) 80÷260 POSITIONING INSTRUMENTS

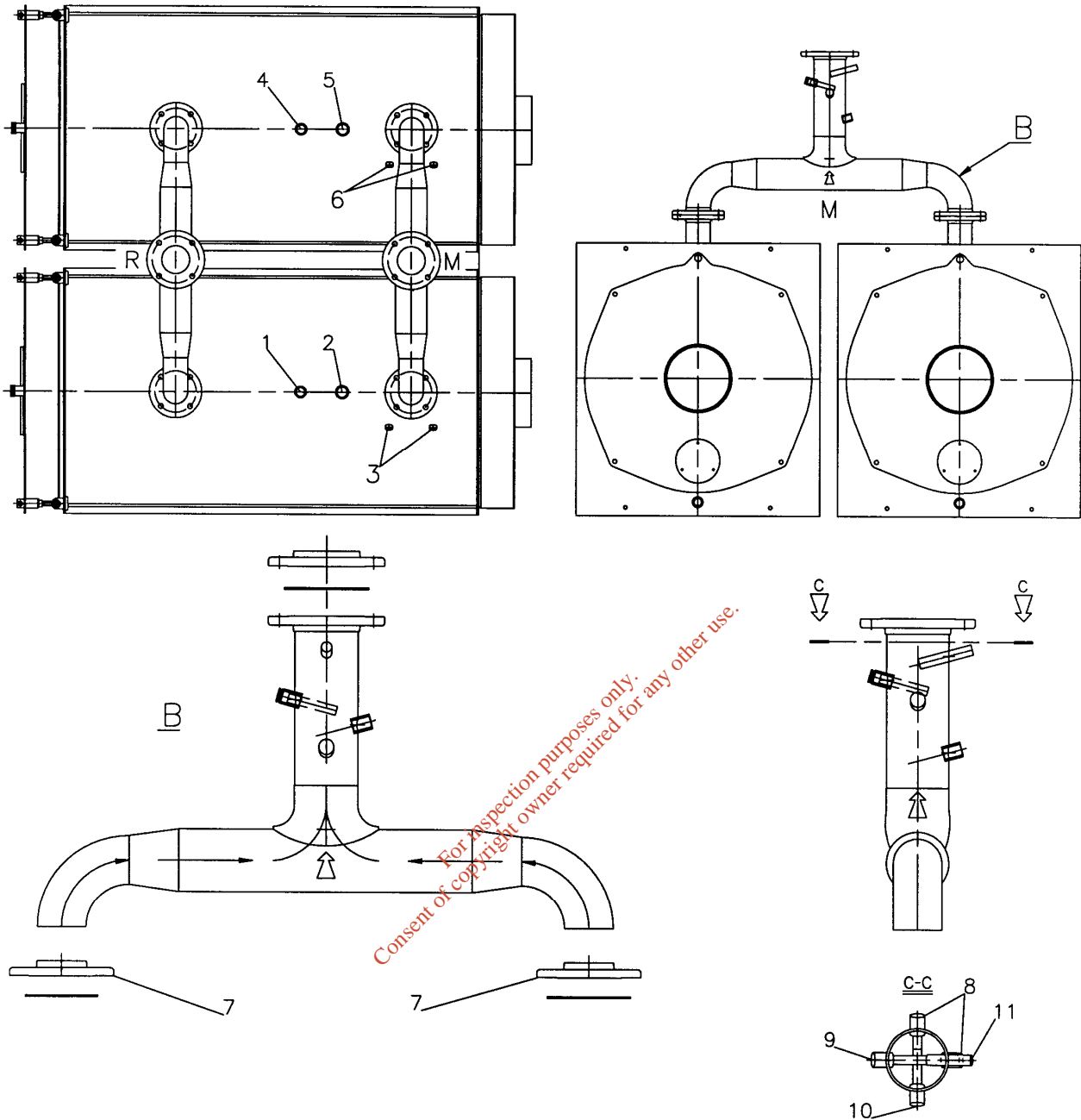

Key

1. Pressure switch fitting
 2. 1st safety valve fitting or thermal drainage 1st safety
 3. 1st boiler circulator consent thermostat and safety thermostat bulb wells
 4. Manometer fitting with control manometer flange
 5. 2nd safety valve fitting or thermal drainage 1st safety
 6. 2nd boiler circulator consent thermostat and safety thermostat bulb wells
 7. Flanges to weld after the definitive and correct positioning of the boilers
 8. 1st and 2nd boiler fuel valve bulbs wells
 9. Boiler thermometer bulb well
 10. 1st and 2nd boiler bi-thermostats bulbs well, digital regulator thermal-resistance (optional)
 11. Temperature test bulb wells
- M. Flow
R. Return

5.3 ELECTRICAL CONNECTION

Electrical systems of thermal plants designed only for heating purposes **must comply with numerous legal regulations which apply to in general as well as specifically to each application or fuel type.**

5.4 REX/REX F/REX K/REX K F OPTIONAL CONTROL PANEL

The control panel (optional) with the boilers is made of self-extinguishing plastic and houses the regulation and safety instruments:

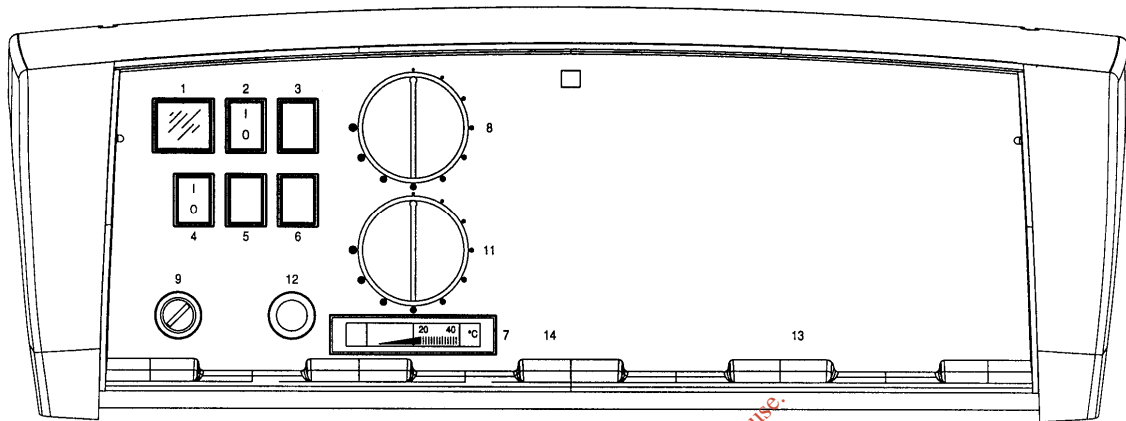

KEY

- 1 PANEL LIVE
- 2 BURNER SWITCH N. 1
- 4 HEATING PUMP SWITCH
- 7 BOILER THERMOMETER
- 8 LIMIT CONTROL THERMOSTAT
- 9 SAFETY LIMIT THERMOSTAT N. 1
- 11 BURNER HIGH/LOW THERMOSTAT

The upper part of the control panel can be rotated to gain access to the terminal board and uncoil the thermostat and thermometer capillaries. A copy of the wiring diagram is contained inside the control panel cover. The **regulation thermostats** have an operating range from 60° to 100° and can be set by the user by means of the front knob.

Safety thermostats has a fixed setting of 110°C and can be manually reset in accordance by law.

Circulator consent thermostat located inside the panel can be adjusted from 0°C to 90°C using a tool and is factory-set at 50°C, while its differential deviation is 6°C. Thanks to this thermostat, the circulator is inactive when the temperature is below 50°C to avoid dangerous exhaust condensation.

For correct installation, refer to the boiler casing assembly instructions.

WIRING DIAGRAM

Refer to the diagram supplied with the specific switchboard.

5.5 INSTALLATION OF REX 140÷350 BOILER CONTROL PANEL

NOTE: the control panel picture is purely indicative as it may vary according to the type of panel installed.

- a. Choose the side on which to install the control panel (RH or LH), remove the covers (1) and push in the pre-cut opening (2).
- b. Pick up the kit of the arm complete with bracket (3).
- c. Open the control panel (4) and cut the preset window on the rear side.
- d. Pass the bulbs (5) of thermostats and thermometer through the window and screw them in the square pipe of the bracket and slide them in the protective tube through top openings until they reach the wells (6). Lock them using the special locking springs.
- e. Connect the cables of burner (7) to the control panel using a protective sheath and lock them with the cable glands (8).
- f. Secure the control panel to the bracket (3) using the kit supplied.
- g. Use the two screws (9) and fasten the arm-control panel group to the top section of the boiler.
- h. Assemble the covers (1).

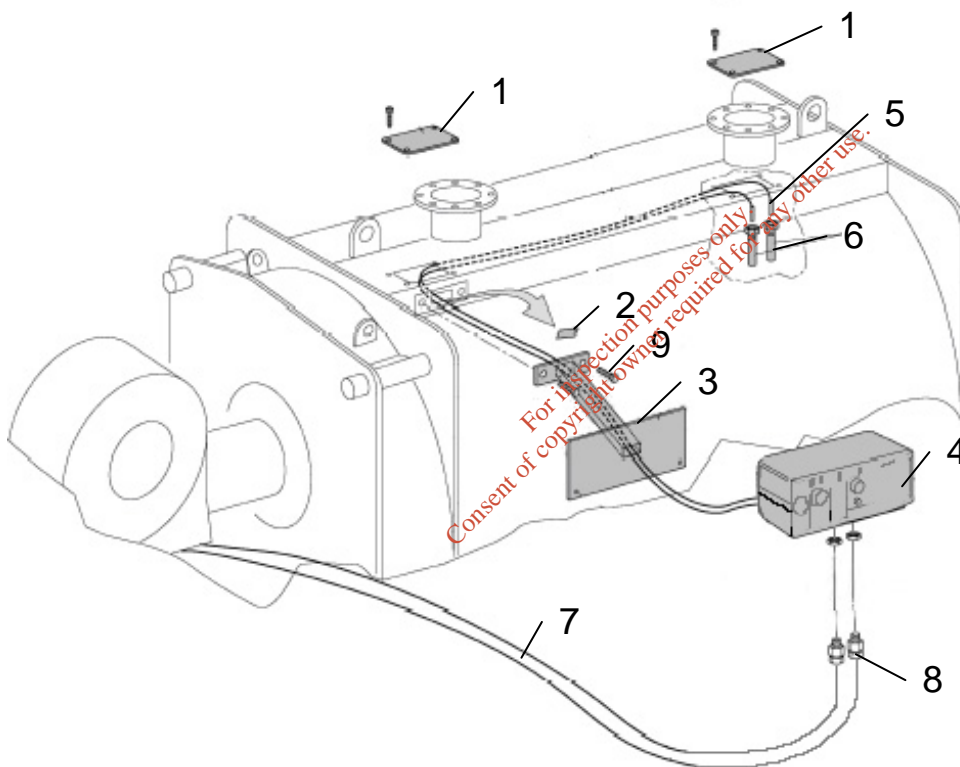

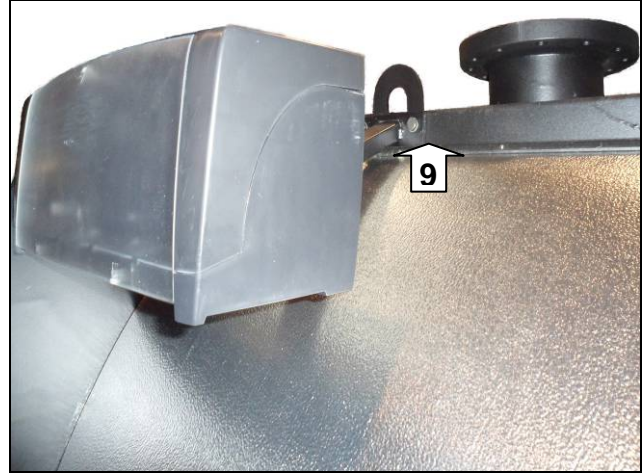
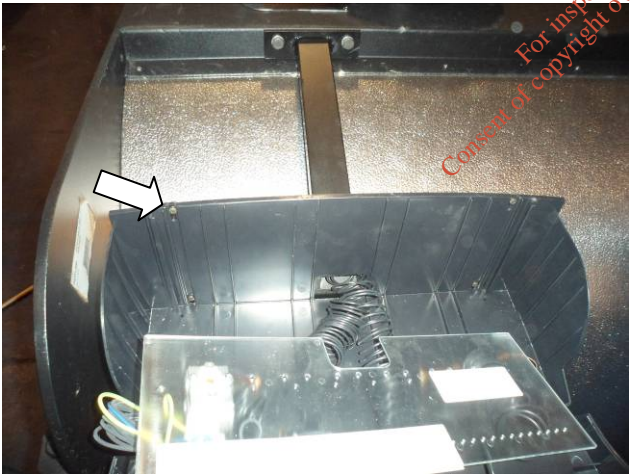
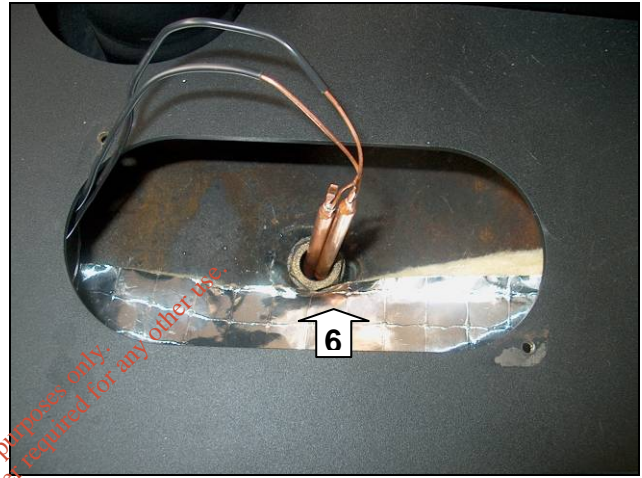
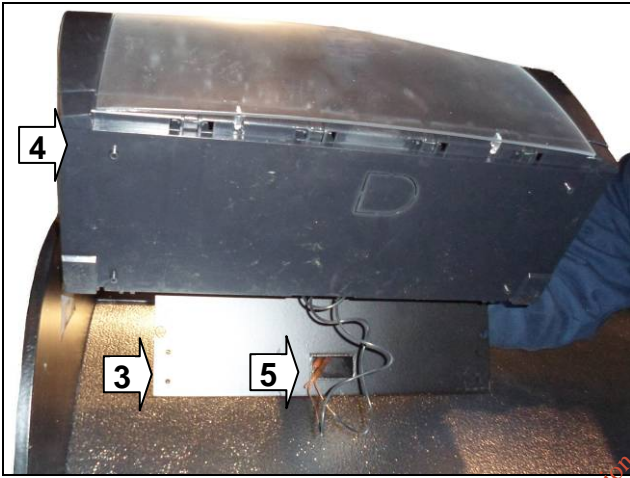
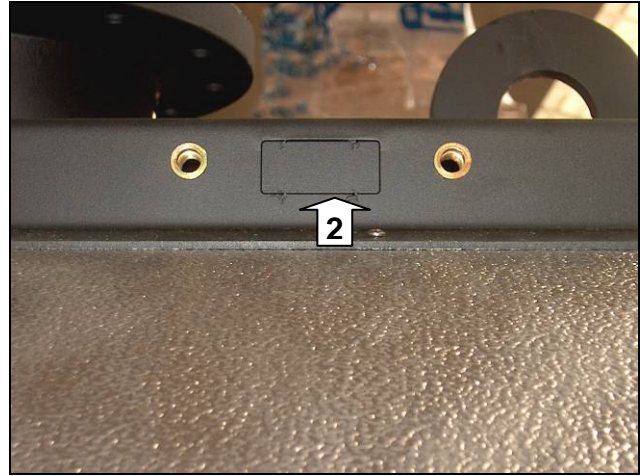
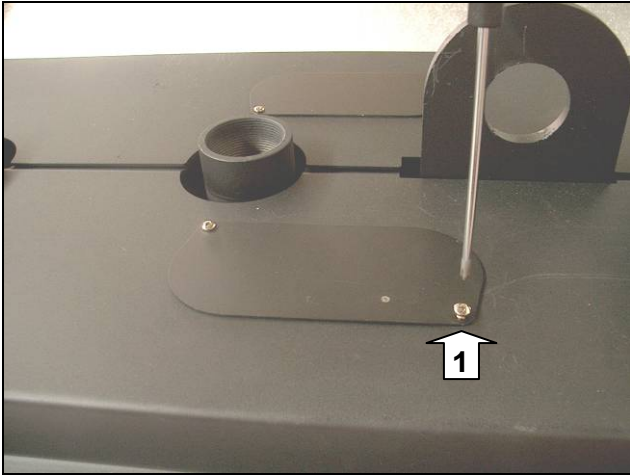

The bracket provided, which is equipped with a 2-hole shaped plate, enables the user to mount the panels with two inclinations, and hence to choose the position he/she prefers (see figures).

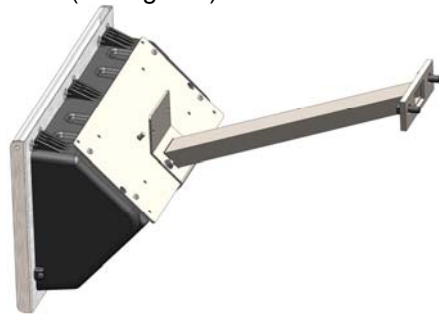
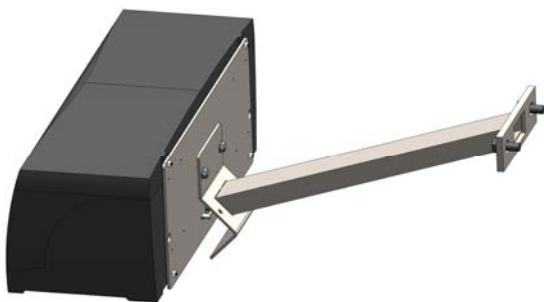

5.6 REX/REX F 400-600 CONTROL PANEL

The generators are equipped with electric board (IP 55 protection level), which are already assembled to the different boiler accessories.

ELECTRONIC CONTROLLER

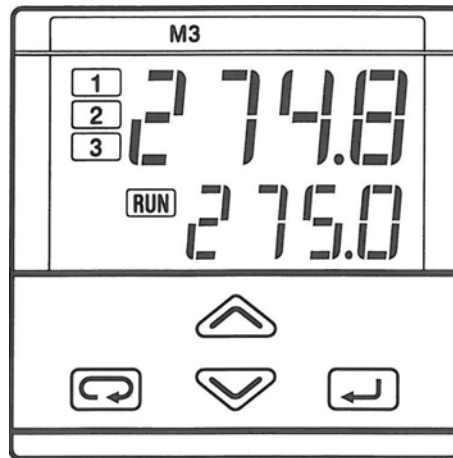



On the controller appear the water temperature in the boiler and can setting three values:





1. OP1 – ON/OFF burner;
2. OP2 – Second stage burner;
3. OP3 – Anticondensate pump.

To change the value:





OP1:

On main screen under the water temperature, can read the value of ON/OFF burner, to change use the button  and  for increase or decrease, wait 2 seconds and the parameter will be saved automatically.

OP2:

From the main screen push  and the parameter A2S.P is the value of the second stage burner; change it with the arrows   and confirm with .

OP3:

From the main screen push  and after  and the parameter A3S.P is the value of the stop anticondensating pump; change it with the arrows   and confirm with .

Note: For more information, refer to the specific manual inside the electrical panel.

WIRING DIAGRAM

Refer to the diagram supplied with the specific switchboard.

5.7 REX DUAL/REX DUAL F OPERATING PRINCIPLES

The boiler consists of 2 units of same capacity and one only control panel for both units. Each unit can work independently and the boiler can be operated partially. This means that all panel controls (burner switches, thermostats and thermometers) have been doubled. See paragraph 6.3 on connection. As an example, bi-thermostats TR1 and TR2 can be adjusted so that there is a 10°C intervention difference between each other (do not forget that knobs have a 30°C a 90°C regulation range with a 1/2 turn rotation about). Flow water temperature after 2 equal flows have been mixed corresponds to mean flow temperature of two units

5.7.1 REX DUAL/REX DUAL F OPTIONAL CONTROL PANEL

NOTE: for boilers with two different control panels, see Par. 5.4

The optional control panel is made of plastic with IP40 protection degree and houses the regulation and safety instruments:

The upper part of the control panel can be rotated to gain access to the terminal board and uncoil the thermostat and thermometer capillaries. A copy of the wiring diagram is contained inside the control panel.

The regulation bi-thermostats have an operating range from 30°C a 90°C and can be set by the user by means of the front knob. The temperature differential of each bi-thermostat is fixed and approx. 10°C.

Safety thermostats have a fixed setting of 110°C and can be manually reset in accordance by law.

Circulator consent thermostats located inside the panel can be adjusted from 0°C to 90°C using a tool and are factory-set at 45°C, while their differential deviation is 6°C. Thanks to these thermostats, the circulators are inactive when the temperature is below 45°C to avoid dangerous exhaust condensation.

For correct installation, refer to the boiler casing assembly instructions.

Note: both hour meters start each time their own burner starts. It is recommended that the numbers displayed by both hour meters are monitored. This helps guarantee that burners have almost the same number of working hours.

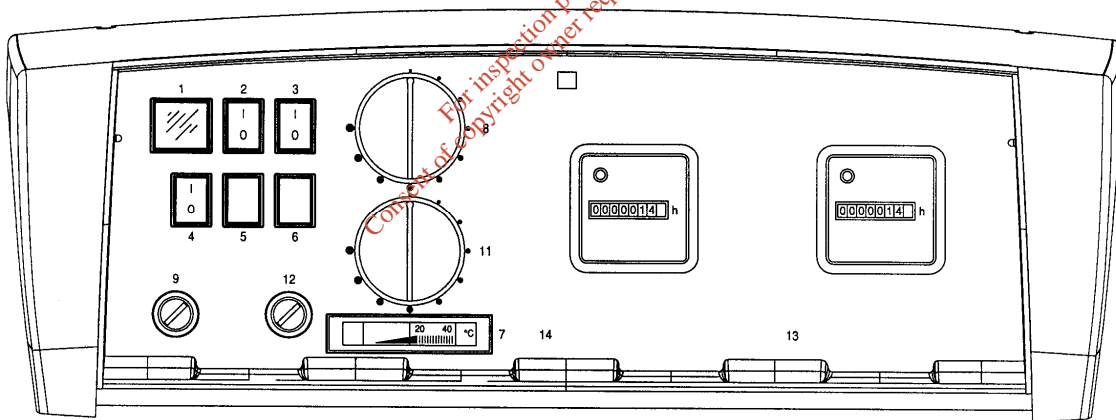

KEY

- 1 PANEL LIVE
- 2 BURNER SWITCH N. 1
- 3 BURNER SWITCH N. 2
- 4 HEATING PUMP SWITCH
- 7 BOILER THERMOMETER
- 8 CONTROL BI-THERMOSTAT N. 1
- 9 SAFETY LIMIT THERMOSTAT N. 1
- 11 CONTROL BI-THERMOSTAT N. 2
- 12 SAFETY LIMIT THERMOSTAT N. 2
- 13 HOURS RUN METER BOILER N. 1
- 14 HOURS RUN METER BOILER N. 2

WIRING DIAGRAM

Refer to the diagram supplied with the specific switchboard.

5.8 DOOR

5.8.1 DOOR OPENING

The door is adjusted in the factory with standard opening to the left (s) and with hinges on the right (d).



CAUTION: it is dangerous to unscrew the ring nuts (8d) on the side of the hinges to avoid causing the door to detach, with possible serious damage to people and property.

5.8.2 DOOR OPENING REVERSAL (to the right)

Only for models listed in the Technical Data table

Proceed as follows to reverse the opening direction of the door:

Door with ferrules perforated on both sides

1. **Screw the left perforated ferrules (8s)** so that the door seal gasket is pressed in the same way as the right part. Bring the conical washers (10s) of the left tie-rods close to the mechanical tubes (9s) of the door and tighten the nuts (7s) using a suitable wrench.
2. On the right opening side, loosen the nuts (7d) and free the conical washers (10d) from the mechanical tubes (9d) of the door.

Door with wrench ferrules, hinge side

IMPORTANT NOTE: In models equipped with wrench-adjustable ferrules (8d), these must always be mounted on the hinges to prevent the door from being accidentally opened through the lever (12).

In this case, proceed as follows:

3. Proceed as indicated in point 1.
4. Cross-change the wrench ferrule of a hinge (8d) with the opposite perforated ferrule (8s), after loosening the locking nuts on the tie rods and freeing the conical washers.
5. On the left hinge side, fasten the conical washer (9s) onto the door using the nut (10s).
6. Proceed with the other two ferrules following the procedure described in points 4 and 5.



CAUTION: When cross-changing ferrules, always make sure that the other two ferrules are fastened, so that they hold the door.

7. Check the correct adjustment of the tie-rods and hinges ensuring that, during closure, the seal gasket is **evenly pressed in the centre on the whole circumference** (see figure).

If necessary, adjust as described in the next par.

5.8.3 DOOR ADJUSTMENT (opening on the right)

Vertical adjustment

1. With the door ajar, loosen the counter-nuts (5s) of the hinge units.
2. Act on the adjustment nuts (4s) to lift or lower the door by centring the gasket on the stop plate (see figure), then block the counter-nuts (5s).
3. Close the door and centre the tie-rod (1d) on the mechanical tube (9d), proceeding as in point 2.

Horizontal adjustment

Close the door using the lever and check that there is equal distance on both sides, between the stop plate and the band.

Otherwise, proceed as follows:

1. With the door ajar, loosen the locking nuts (7s) of the hinge units.
2. Act on the ferrule (8s) to adjust the distance depth-wise.
3. Screw the nuts (7s) and block the conical washers on the mechanical tubes.

Check the proper adjustment in depth ensuring that the door, manually pushed up to the stop plate, naturally returns remaining ajar. This is to ensure the hinge side fume seal.

For any problems related to the reversal and adjustment of the door, we recommend contacting our local Authorised Technical Assistance Centre.



IMPORTANT: Incorrect door adjustment with consequent damage to people and property voids the warranty conditions.

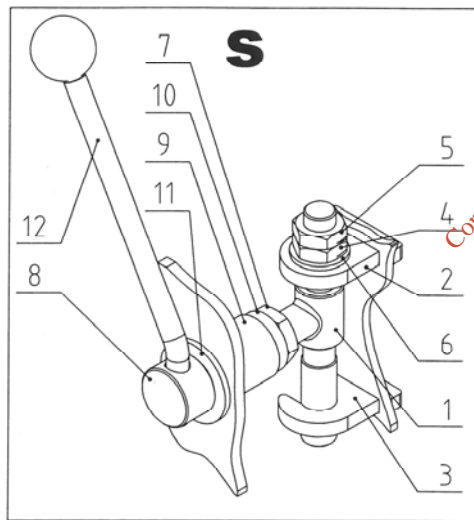

OPENING UNIT

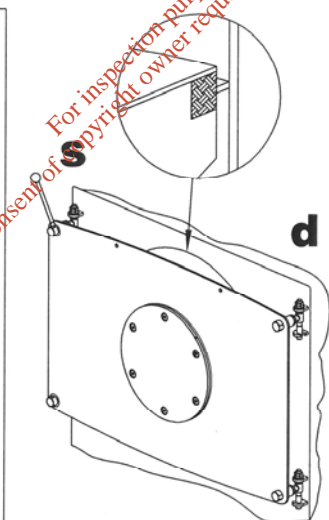

HINGE UNIT

KEY

- | | |
|----------------------------------|---|
| 1. Tie-rod with pin | 8. Perforated ferrule for opening (s)
Wrench ferrule for hinge (d) |
| 2. Upper bracket | 9. Door mechanical tube |
| 3. Lower bracket | 10. Conical centring washer |
| 4. Vertical adjustment nut | 11. Opening lever washer |
| 5. Locking counter nut | 12. Opening lever |
| 6. Vertical tie-rod plain washer | |
| 7. Horizontal locking nut | |

5.9 BURNER CONNECTION

Before installation you are advised to thoroughly clean the inside of all the fuel supply system pipes in order to remove any foreign matter that could affect correct operation of the boiler. See technical specification tables and check the max pressure value inside the furnace. The value found on the table may also increase by 20% if heavy oil is used instead of gas or light oil; furthermore the following checks should also be carried out:

- a) Check the internal and external seal of the fuel supply system;
- b) Regulate the fuel flow according to the power required by the boiler;
- c) Check that the boiler is fired by the correct type of fuel;
- d) Check that the fuel supply pressure is within the values specified on the burner rating plate;
- e) Check that the fuel supply system is sized for the maximum flow rate necessary for the boiler and that it is provided with all control and safety devices provided for by the regulations referred to above;
- f) Check that the boiler room vents are sized in order to guarantee the air flow established by the regulations referred to above and that they are in any case sufficient to obtain perfect combustion.

In particular, when using gas:

- g) Check that the feeding line and the gas ramp comply with the regulations in force;
- h) Check that all the gas connections are sealed;
- i) Check that the gas pipes are not used as earth connections for electrical appliances.

If the boiler is not going to be used for some time, close the fuel supply cock or cocks.

IMPORTANT: check that the air spaces between the burner draught tube and the manhole are suitably filled with thermoinsulating material.

The thermoinsulating strip provided with the boiler must be wrapped around the mouthpiece for at least an entire circumference of the flame radiation to protect the flange of the burner. Not that the ceramic insulation is necessary to fill the gap until the insulation inside surface of the door.

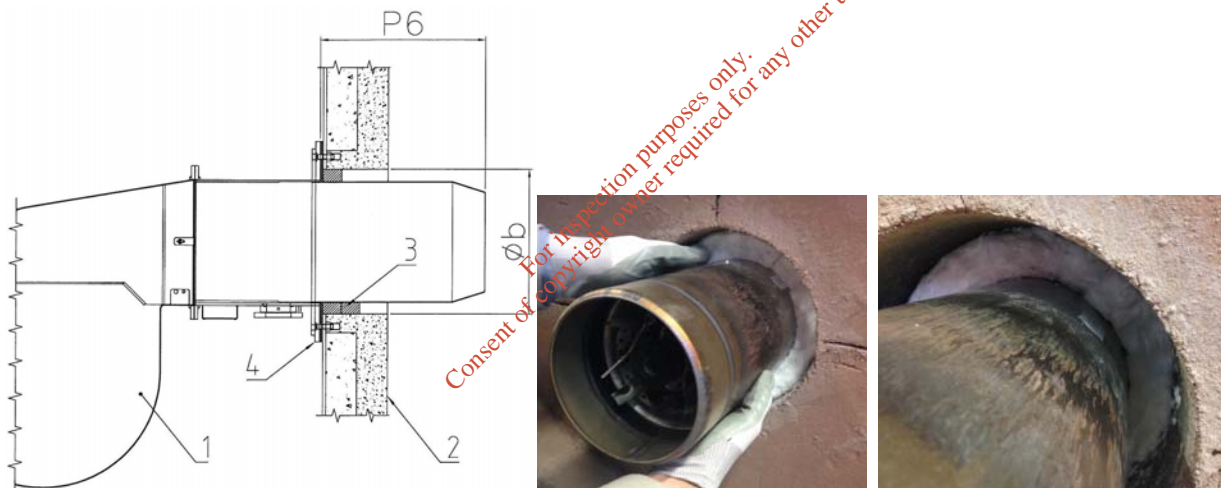

The above picture is only for reference.

KEY:

1. Burner
2. Manhole
3. Thermoinsulating material
4. Flange

All details on the draught tube length (P6), the diameter of the burner hole (ϕb) and the pressurization are included in the par. Technical Specifications.



ATTENTION: when using oil or bio-gas for operation, the door must have cement insulation and special tie rods. Any alterations and/or lack of communication during the selling phase shall nullify the warranty conditions.

6 ASSEMBLY

6.1 REX K/REX K F ASSEMBLY

Ensure that installation premises floor is even and perfectly horizontal.

For perfect welding, use acid or rutile cored electrodes (check codes AWS E6020 or AWS E6013 or E44LA3 or E44LC3).

- a) Put the boiler rear plate (1) on the floor with the hinges pointing down and ensure that it is perfectly levelled (mark the middle of the plate sides in order to position correctly the furnace and the tube nest.
- b) Position the furnace (2) on the internal edge of the front plate (1) keeping the longitudinal welding of the furnace in the lower part of the boiler. **Ensure that plate and furnace are perfectly perpendicular when coupling them.**
- c) Weld the furnace (2) onto the front plate (1) along the outer circumference.
- d) Add the top tube nest part (3)* (the return stub which can be recognised by its flow trap (4) welded inside the tube nest, must be close to the front tube plate). **For positioning, ensure that the flanged stub hole axis is aligned with the sign previously marked on the plate middle.** For easy centering, check height **A** between the tube nest edge and the plate edge. Spot-weld the middle only.
- e) Position the lower tube nest (5)* in respect of height **B** and spot-weld it only in the lower middle part of the rear plate (1).
- f) Spot-weld the two tube nest parts (3)* and (5)*
- g) Position the rear tube plate (6) and insert the tie rod or the stiffening stub (8) in the furnace.
- h) Weld the rear tube plate (6) and the tie rod or stiffening stub (8), carefully avoiding any damage to the four threaded rivets or screws which will be used to secure the smokebox.
- i) Weld all the nest (3)* and (5)* onto the rear plate (1).
- j) Now, smoke tubes (7) can be inserted and welded on the rear plate tube (6) keeping the boiler in upright position or (but welding will be more difficult) horizontally; the choice will depend on the size of premises and the equipment available to turn the boiler upside down. **Caution: smoke tuber (7) must protrude 3 mm from the front plate (1) and approx. 10 mm from the rear plate (6).**

NB: the condensate groove for the F version (with extruded aluminium) must be positioned in the lower section.

- k) Spot-weld the drain (N4) and ensure that it is perpendicular to the front plate (1) and parallel to the tube nest.
- l) Position the boiler horizontally. For this reason, a lifting hook is supplied that can be conveniently welded to the tube nest in order to simplify the boiler overturning. Remember not to have this hook protruding from the casing.
- m) Weld the two parts of the tube nest (3)* and (5)* longitudinally as well as the furnace inside (2) to the front plate (1); you can simplify this operation by using rolls for rotating.
- n) Weld both ½" couplings (N6) onto the tube nest (3)* after having ensured that the bulb sheaths inclination is correct to avoid that sheaths are not blocked by smoke tubes; remove sheaths when welding. Weld the two flanged stubs (N1) and (N2) for flow and return, ensuring that flanges are perfectly horizontal. Weld the instrument fitting (N3) and fittings (N5) if included in the supply.
- o) Weld smoke tubes (7) onto the rear plate (1).
- p) Ensure that plate shapes (1) and (6) have not been altered and weld on plate surface the side frames (9).
- q) Weld the square tubes (10) that support the casing and, if part of the supply, weld also the side ones keeping height **C**.
- r) Carry out the hydraulic test under pressure. **FILL THE GUARANTEE WITH THE TEST DATE.**
- s) Install the manhole (11) and the smoke box (12).
- t) Touch-up visible parts by using the paint supplied.

* **NB: ref. 3-5, single piece up to mod. 25**

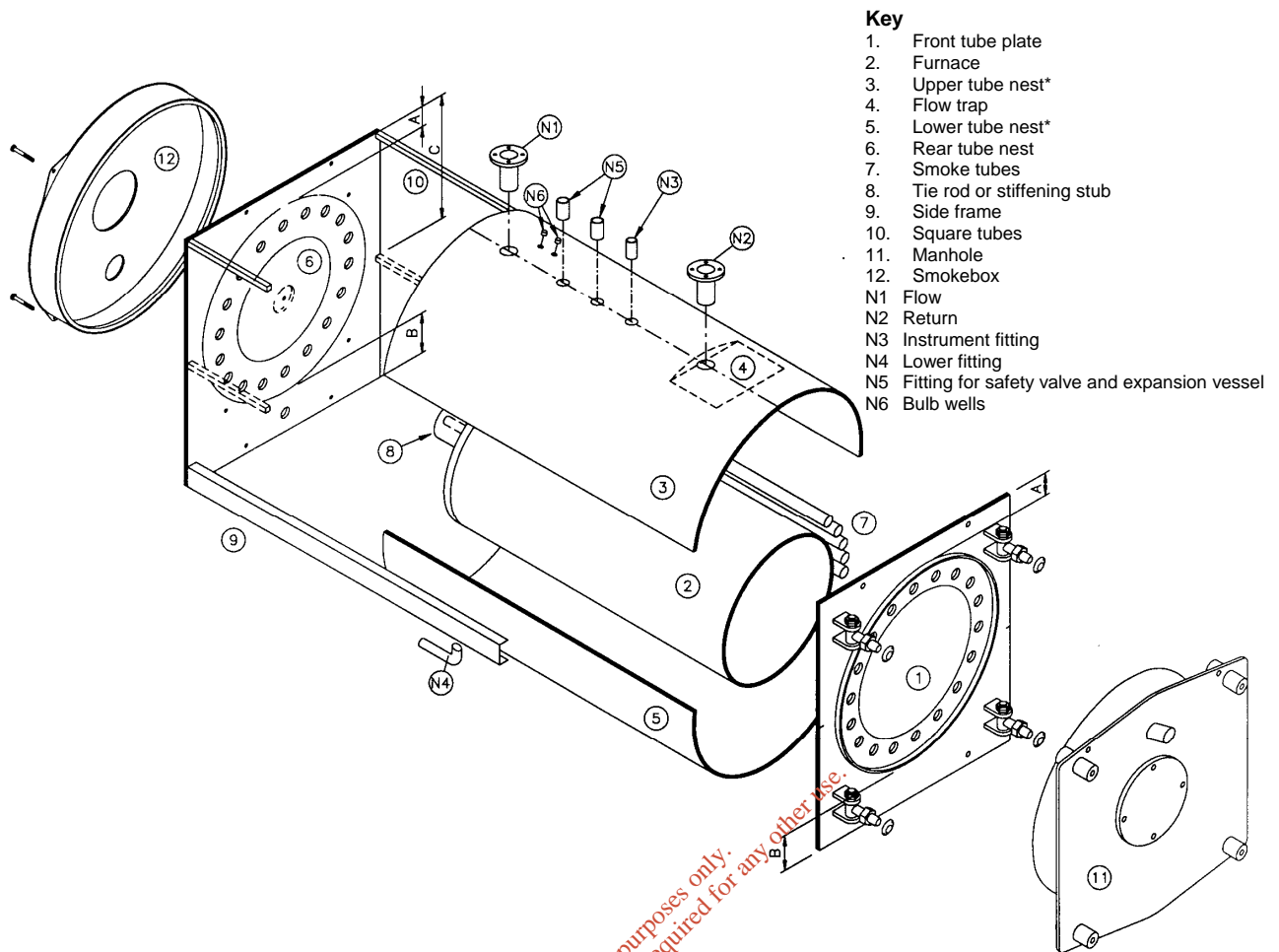

Key

- 1. Front tube plate
- 2. Furnace
- 3. Upper tube nest*
- 4. Flow trap
- 5. Lower tube nest*
- 6. Rear tube nest
- 7. Smoke tubes
- 8. Tie rod or stiffening stub
- 9. Side frame
- 10. Square tubes
- 11. Manhole
- 12. Smokebox
- N1 Flow
- N2 Return
- N3 Instrument fitting
- N4 Lower fitting
- N5 Fitting for safety valve and expansion vessel
- N6 Bulb wells

* NB: ref. 3-5, single piece up to mod. 25

MOD	7	8	9	10	12	15	20	25	30	35	40	50	62	75	85	95	100	120	130	140	160	180
A	100	100	100	100	100	100	100	100	100	100	85	85	85	85	85	85	85	85	85	85	85	85
B	100	100	100	100	100	100	100	100	100	100	95	125	125	125	125	125	125	125	125	215	215	215
C	-	-	-	-	-	-	-	-	-	-	-	550	550	605	605	605	680	680	680	-	-	-

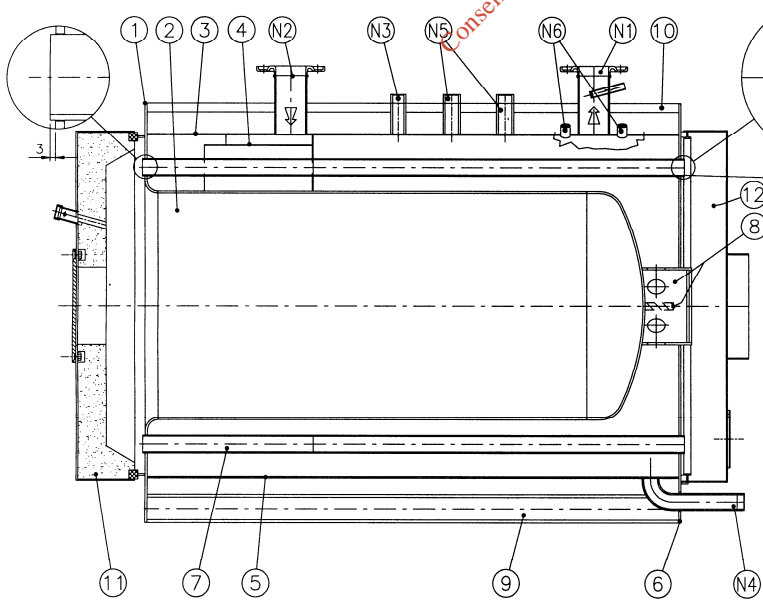

DIMENSIONS AND WEIGHTS OF THE BULKIEST PARTS

MOD.	Tube nest*/Furnace			Manhole		
	Ø mm	length mm	weight kg	width mm	height mm	weight kg
7*	631	620	30	700	630	33
8*	631	620	30	700	630	33
9*	631	745	35	700	630	33
10*	631	745	35	700	630	33
12*	631	745	35	700	630	33
15*	681	990	50	750	680	40
20*	681	990	50	750	680	40
25*	681	1240	63	750	680	65
30	500	1240	73	850	778	90
35	500	1490	88	850	778	90
40	545	1490	115	890	807	110
50	645	1500	145	1100	984	180
62	645	1790	172	1100	984	180
75	690	1800	227	1240	1130	210
85	690	1800	227	1240	1130	210
95	690	2050	257	1240	1130	210
100	790	2065	316	1390	1270	235
120	790	2065	316	1390	1270	235
130	790	2065	316	1390	1270	235
140	845	2378	390	1470	1367	435
160	845	2378	390	1470	1367	435
180	845	2588	425	1470	1367	435

6.2 REX/REX F/REX K/REX K F BOILER CASINGS AND CONTROL PANEL

- 1) Wrap the fibreglass around the boiler body and use the supplied strap to secure it (see fig.).

DIAGRAM OF PLASTIC STRAP LOCKING
TO SECURE THE FIBREGLASS
TO THE BOILER SHELL

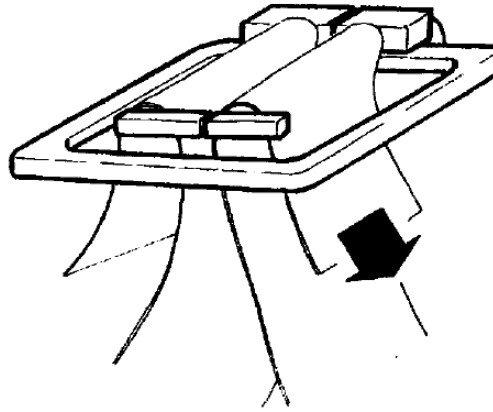

- 2) Prepare the staves by inserting the four stoppers, as shown in the figure.

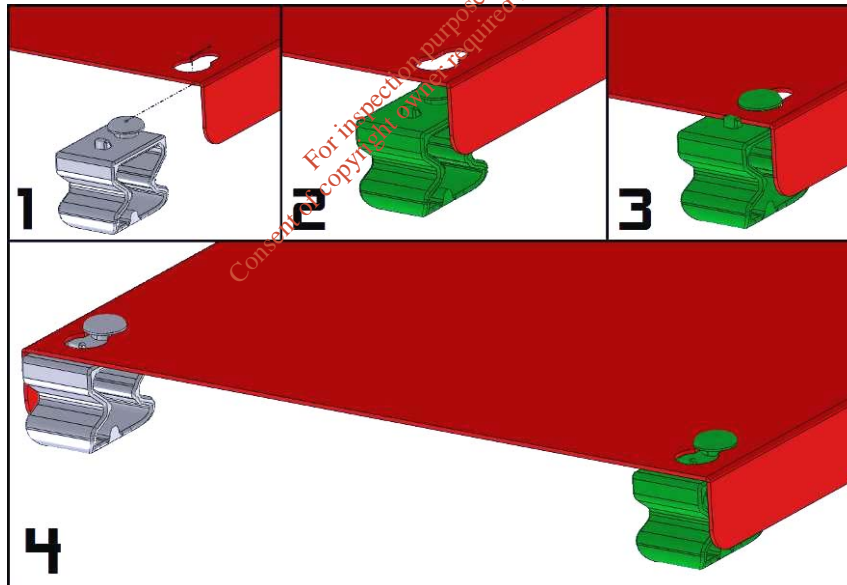

3) Fasten the uprights and the beams to the plates by means of appropriate screws and nuts.

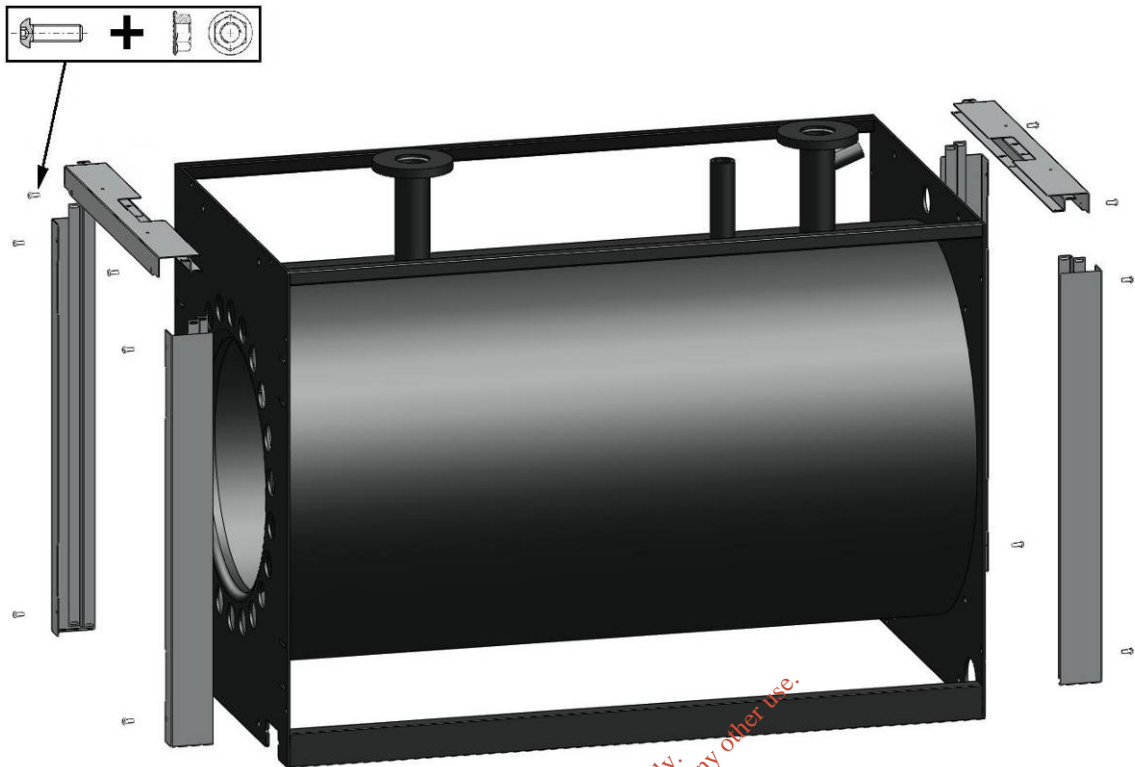

NOTE: the beam shown in the figure, if supplied in the package, must be placed between the two tube panels in order to support the staves.

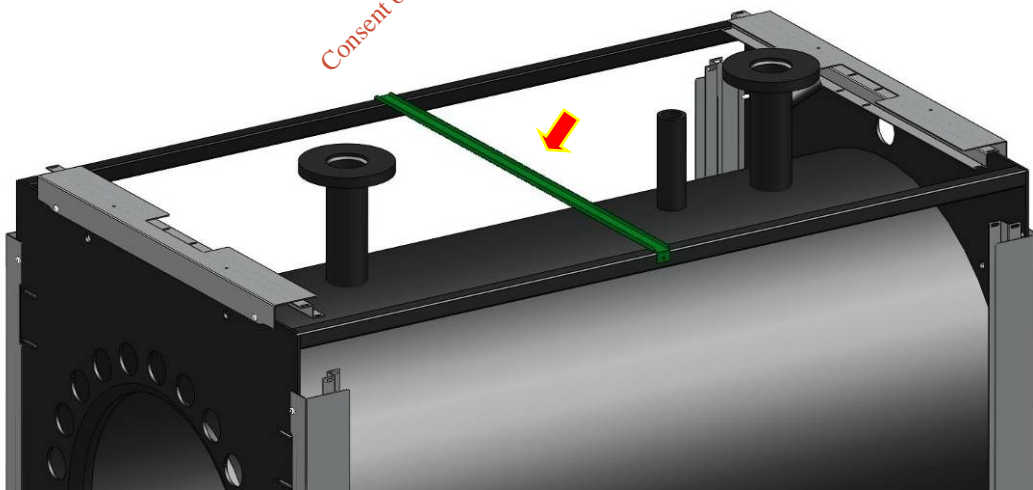

-
- 4) Insert the staves, with the previously installed stoppers, between the uprights and the beams, as shown in the figure.

PLEASE NOTE: do not cover the upper corner on the manhole side; this is required for the subsequent installation of the control panel and its bulbs.

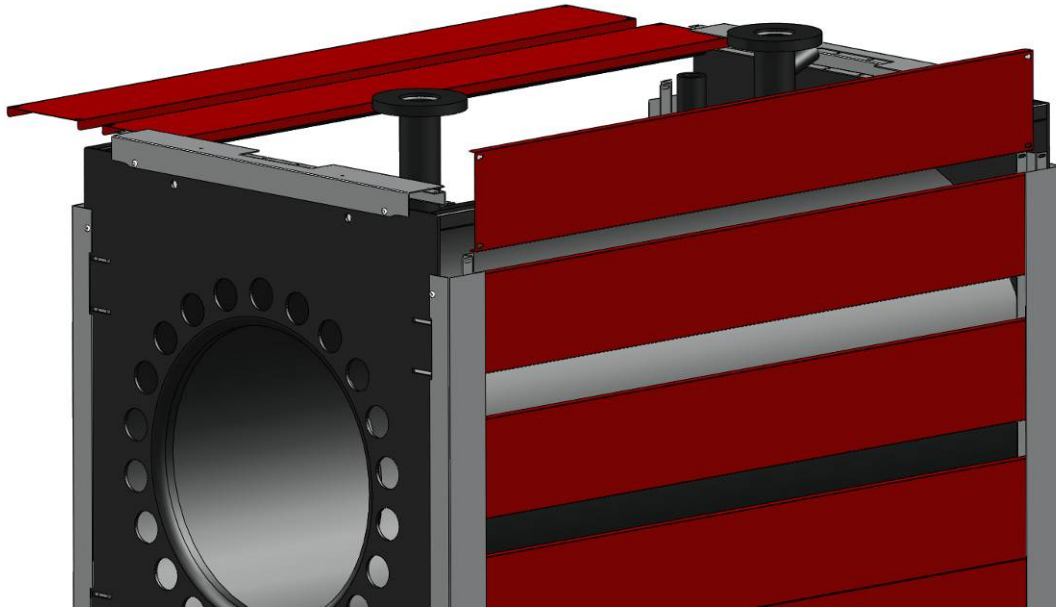

- 5) After inserting the lags and fastening the relevant central masks (1), install the closing profiles (2) using the self-tapping screws, on the side opposite the manholes.

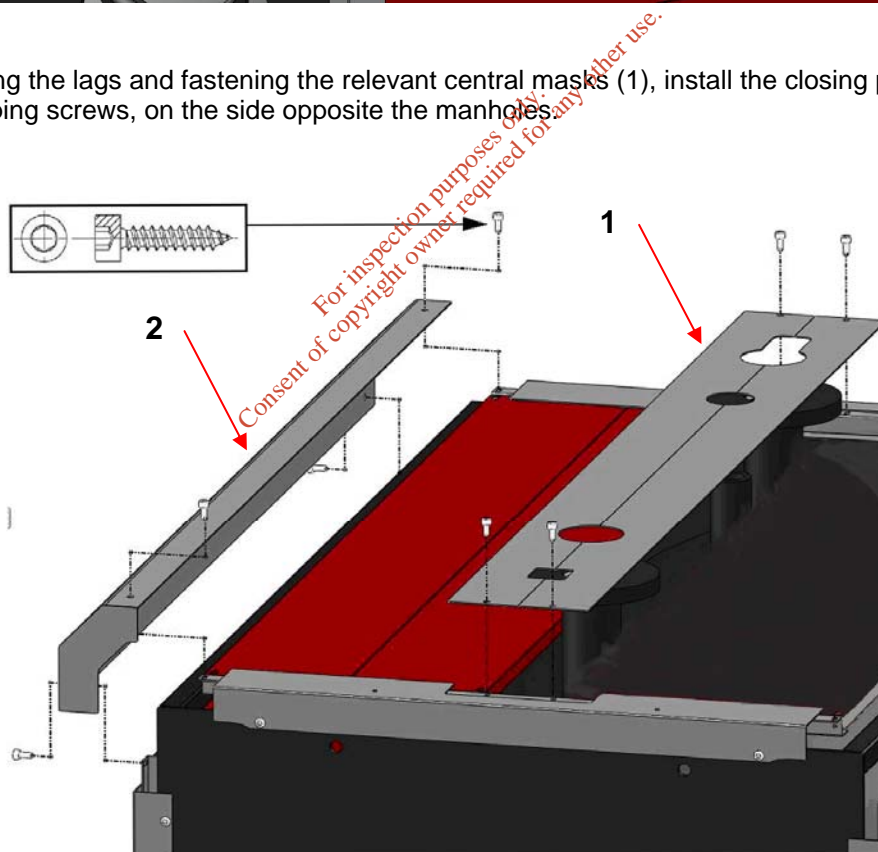

CONTROL PANEL INSTALLATION

NOTE: the control panel picture is purely indicative as it may vary according to the type of panel installed.

- 6) Install the control panel support (3) included in the kit on the front beam of the boiler.
- 7) Place the control panel (4) onto the support (3) and insert the boiler adjustment thermostats capillary tubes, the safety thermostat capillary tubes, the circulator consent thermostat capillary tubes and the boiler thermometer capillary tubes through the relevant openings, until the bulb-holding manholes (5) on the shell have been reached.

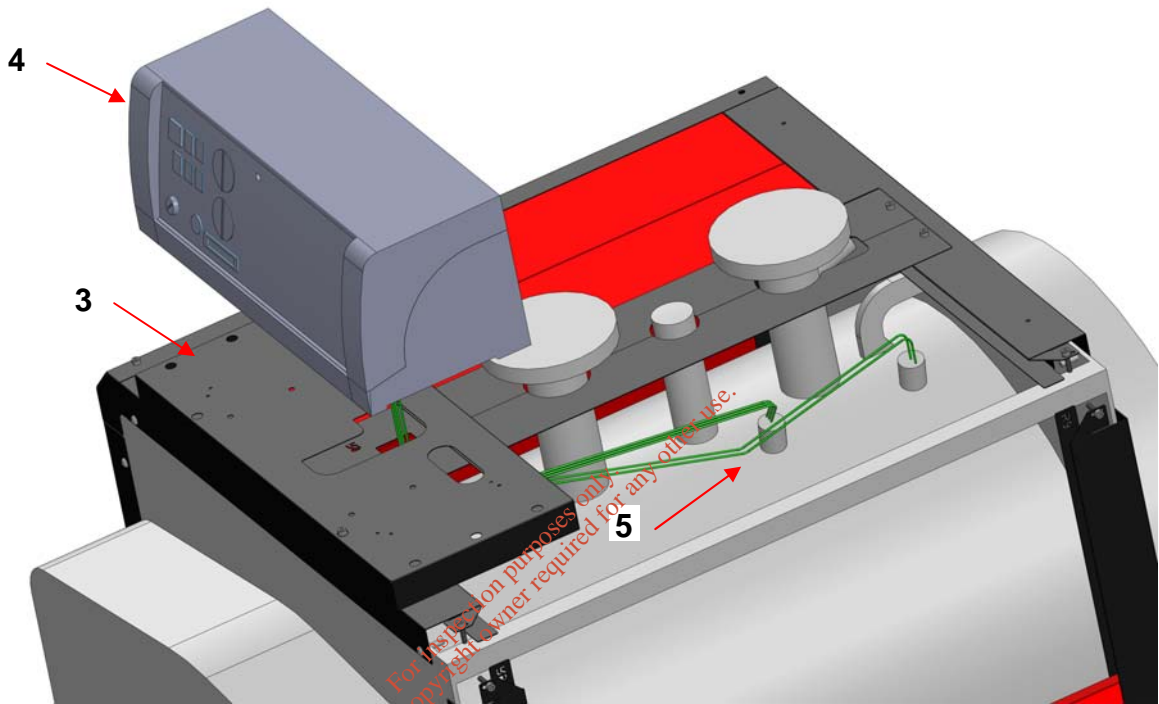

- 8) Fasten the control panel onto the support using the screws provided.
- 9) Finish inserting the lags and installing the closing profiles (2) using the self-tapping screws on the man-hole side.

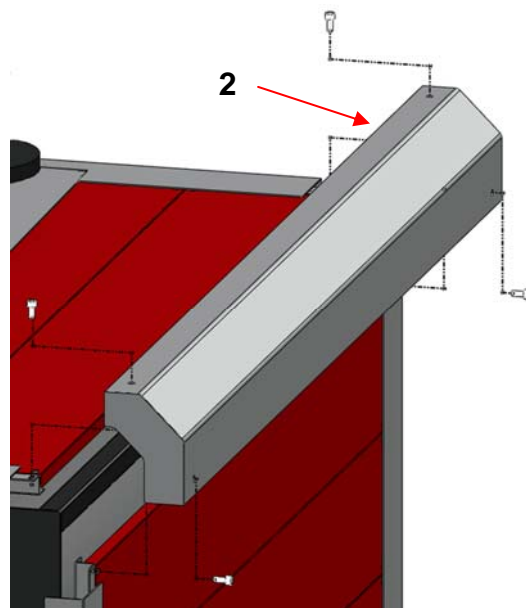

6.3 REX DUAL/REX DUAL F BOILER CASINGS AND CONTROL PANEL

STACKED BOILERS

For stacked boilers, 2 kits are supplied: the standard kit for the upper boiler and a special kit for the lower boiler. The main difference is the control panel support stave (1) to be mounted where preferred and the two closing frames (2) supplied in lieu of the upper staves (3) which are not applicable.

NOTE: For installation, please refer to the manual of the individual boiler. In the figure, all lags are already inserted, but before closing the upper corners on the manhole side, the control panel is to be installed along with the relevant bulbs, as described below.

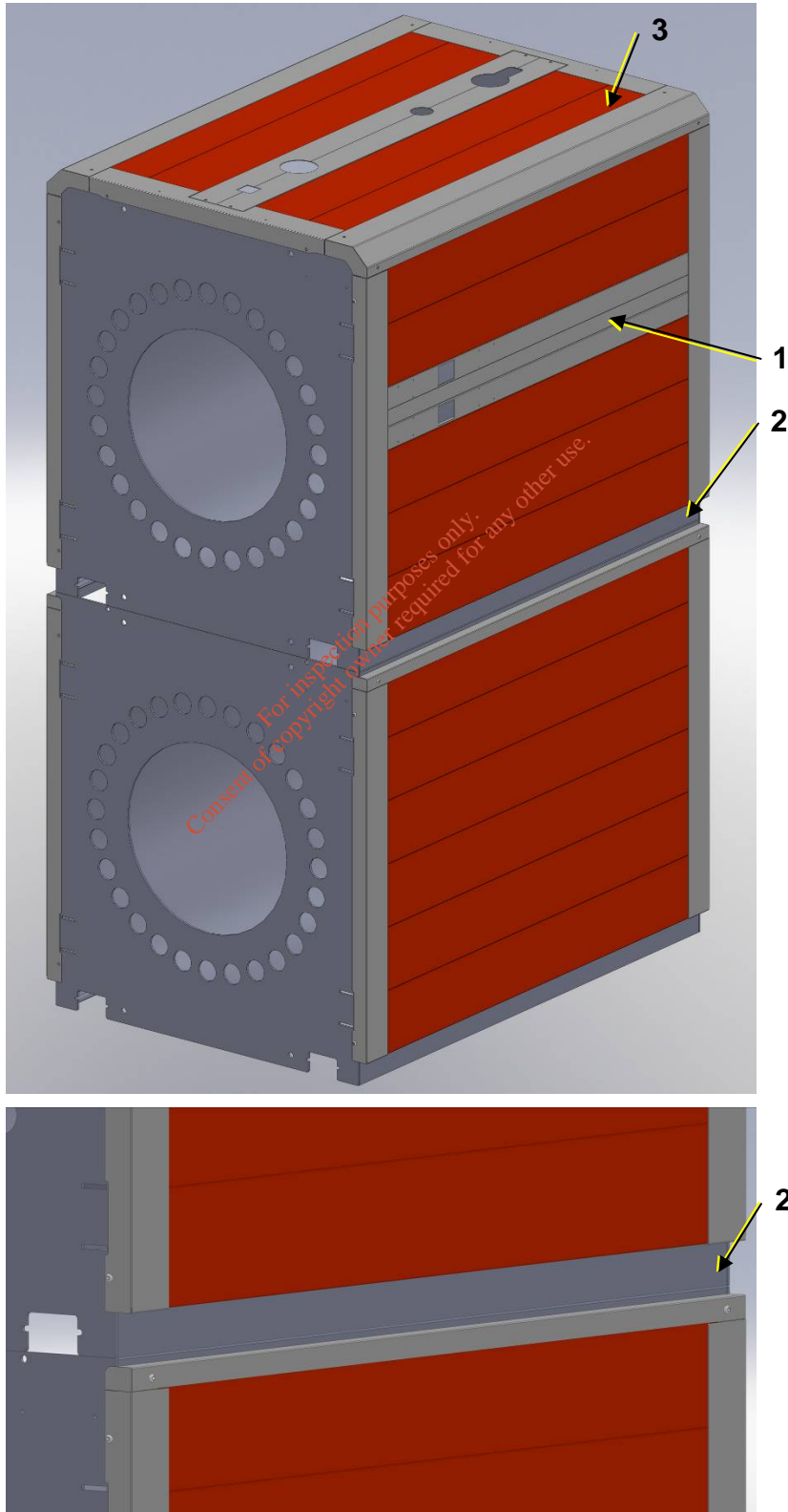

CONTROL PANEL INSTALLATION

NOTE: the control panel picture is purely indicative as it may vary according to the type of panel installed.

- 10) Place the control panel (4) close to the panel-holding lag (1) and insert the adjusting thermostats capillary tubes of the 1st and 2nd boiler with thermometer through the openings provided. They must be inserted into the manholes of the flow pipe (5); then the safety thermostat and the circulator consent thermostat of the 1st boiler into the manholes on the shell (6); finally, the safety thermostat and the circulator consent thermostat of the 2nd boiler into the manholes on the shell (7).

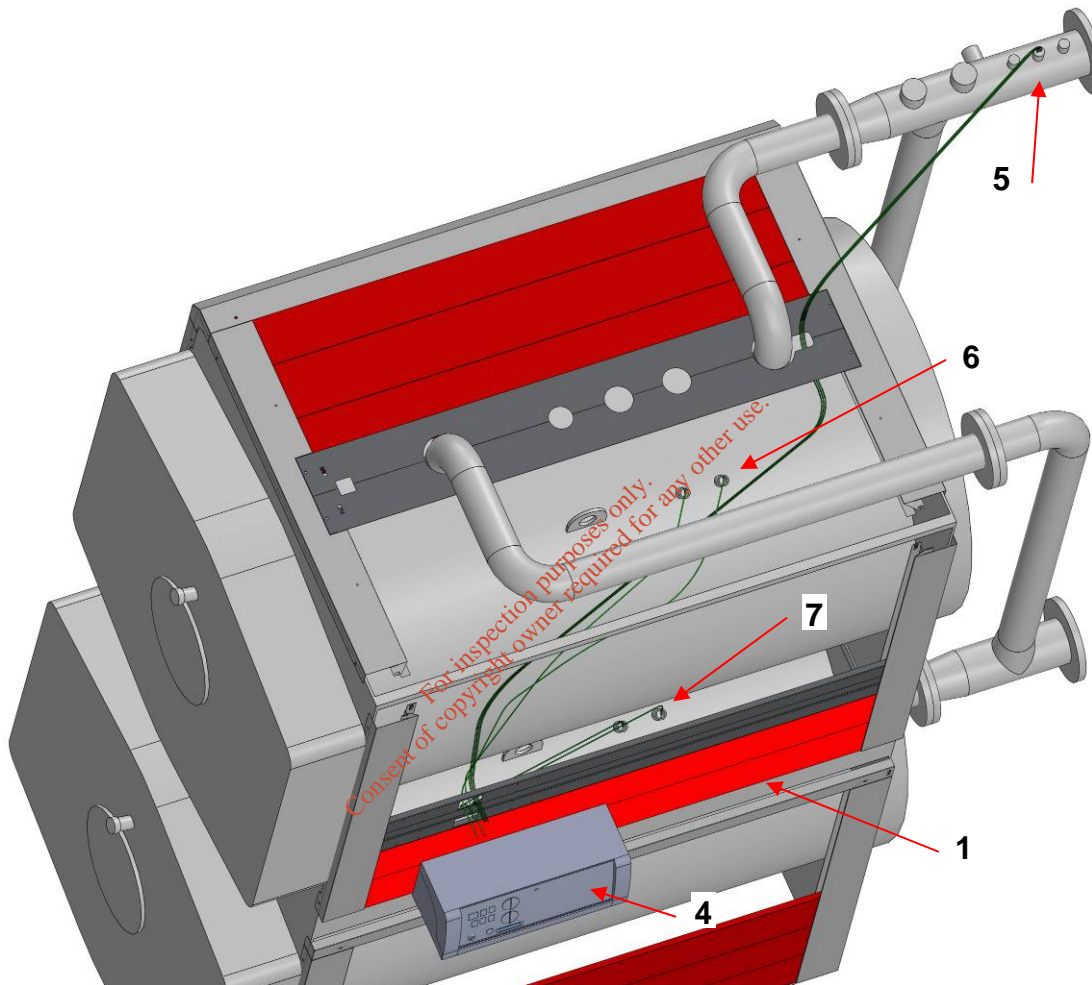

- 11) Fasten the control panel (4) onto the lag (1) using the screws provided.
- 12) Finish inserting the lags and installing the closing profiles using the self-tapping screws on the manhole side, as shown in point 9).

SIDE BY SIDE BOILERS

For combined boilers, 2 standard kits are provided. The installation process is the same as the one described for single boilers. For the positioning of the boiler's bulbs see par. 5.2.3.

7 START UP

WARNING: Before start up, open the door and insert wholly turbolators into the front end sections of the smoke tubes, ensuring that they have been pushed inside for at least 100 mm.

7.1 PRELIMINARY CHECKS

Before starting the boiler, check that:

- The **rating plate** specifications and power supply network (electricity, water, gas or fuel oil) specifications correspond;
- The burner **power range** is compatible with the power of the boiler;
- The boiler room also contains the instructions for the burner;
- The **flue gas exhaust pipe** is operating correctly;
- The **air inlet supply** is well dimensioned and free from any obstacle;
- The **manhole**, the **smokebox** and the **burner plate** are closed in order to provide a complete flue gas seal;
- The system is **full of water** and that any **air pockets** have therefore been eliminated;
- The **anti-freeze** protections are operative;
- The water **circulation pumps** are operating correctly.
- The expansion vessel and the safety valve(s) have been connected correctly (with no interception) and are properly operating.
- Check the electrical parts and thermostat operation.



The above picture is only for reference

7.2 WATER TREATMENT

The most common phenomena that occur in heating systems are:

- Scaling

Scale obstructs heat transfer between the combustion gases and the water, causing an abnormal increase in the temperature of the metal and therefore reducing the life of the boiler.

Scale is found mostly at the points where the wall temperature is highest and the best remedy, at construction level, is to eliminate areas that overheat.

Scale creates an insulating layer which reduces the thermal transfer of the generator, affecting system efficiency. This means that the heat produced by burning the fuel is not fully exploited and is lost to the flue.

Scale diagram

Key

% % fuel not used
mm mm scale

- Corrosion on the water side

Corrosion of the metal surfaces of the boiler on the water side is due to the passage of dissolved iron through its ions (Fe⁺). In this process the presence

of dissolved gases and in particular of oxygen and carbon dioxide is very important. Corrosion often occurs with softened or demineralised water which has a more aggressive effect on iron (acid water with Ph <7): in these cases, although the system is protected from scaling, it is not protected against corrosion and the water must be treated with corrosion inhibitors.

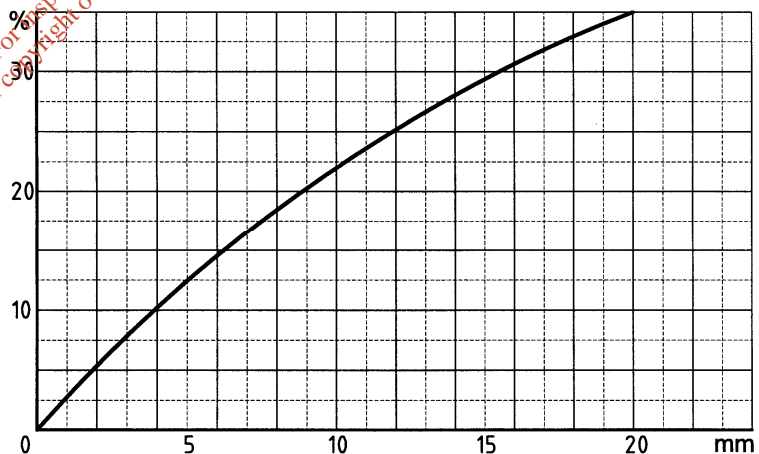

7.3 FILLING THE SYSTEM

The water must enter the system as slowly as possible and in a quantity proportional to the air bleeding capacity of the components involved. Filling times vary depending on the capacity and characteristics of the system but should never be less than 2 or 3 hours.

In the case of a system with closed expansion vessel, water must be let in until the pressure gauge indicator reaches the static pressure value pre-set by the vessel.

Heat the water to maximum temperature. During this operation the air contained in the water is released through the automatic air separators or through manual bleed valves. The water discharged from the system with elimination of the air is made up by the automatic or manual filling valve.

8 OPERATION

8.1 OPERATING CHECKS

The heating system must be correctly operated to ensure perfect combustion as far as possible with reduced emissions of carbon monoxide, unburnt hydrocarbons and soot into the atmosphere, and to avoid hazards and damage to people and goods. Guide to combustion values:

FUELS	%CO ₂	Flue gases temperature	% CO
Gas	10	190°C	0 – 20 ppm
Gas oil	13	195°C	10 – 80 ppm
Heavy oil	13.5	200°C	50 – 150 ppm

A diagram is provided in which the system efficiency is obtained according to the flue gas temperature, the ambient temperature and the percentage of carbon dioxide (CO₂). Dispersions through the boiler casings are not considered.

Example:

Flue gas temperature.....210 °C

Ambient temperature.....20 °C

%CO₂.....13 %

Fuel usedGAS OIL

Efficiency.....91.4 %

% EFFICIENCY CHART (significant losses only)

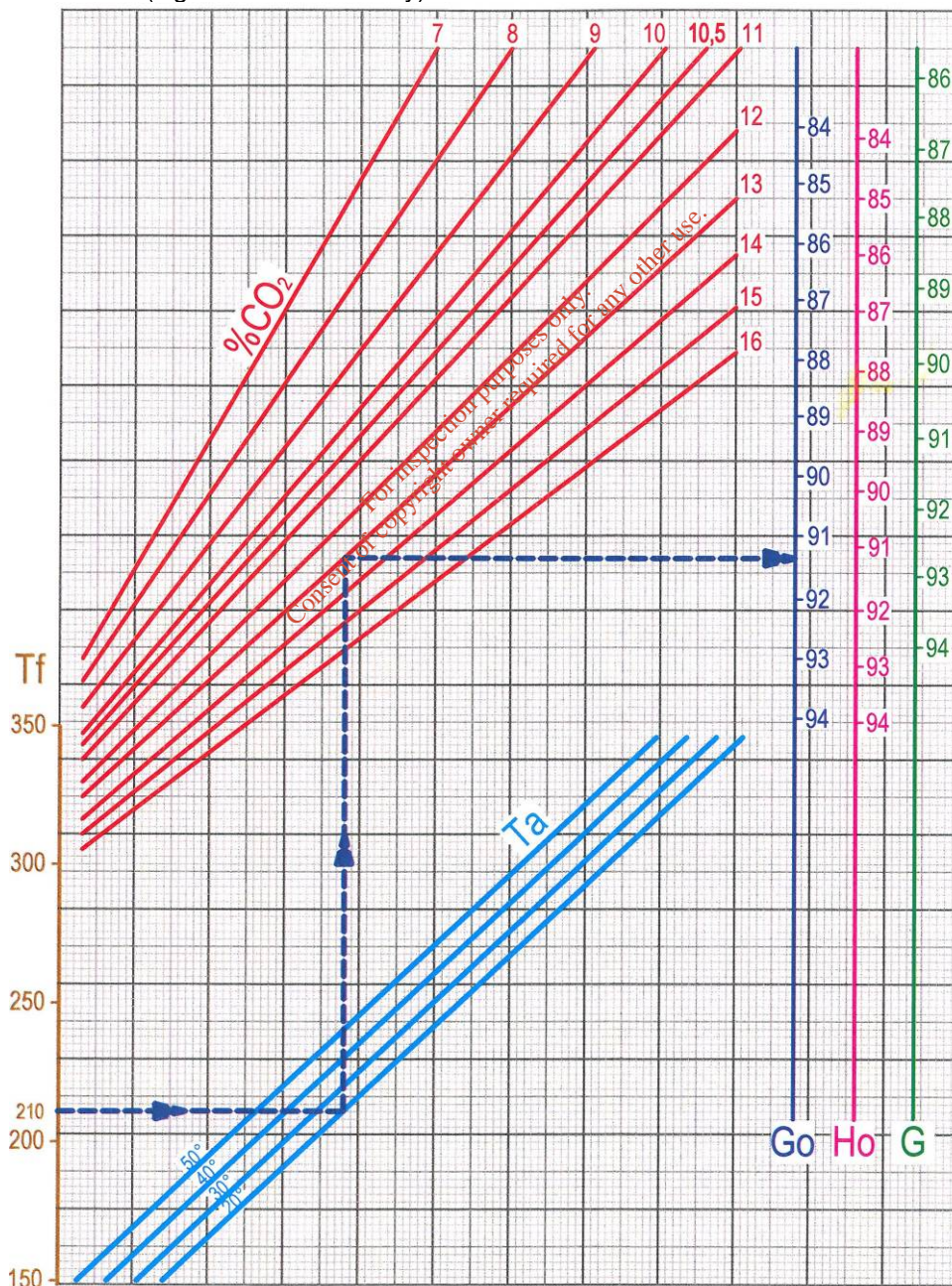

Key:

Tf Flue gas temperature – Ta Ambient temperature °C – Go Gas oil – Ho Heavy oil – G Gas

Pressurisation values should be included in the range given in the table of technical specifications.

IMPORTANT

The delta T between flow and return must not exceed 30°C, in order to avoid thermal shocks in the boiler. The boiler return temperature must be higher than 50°C on natural gas or LPG firing and higher than 40°C on oil firing, in order to protect the boiler from corrosion due to acid flue gas condensation; the guarantee therefore does not cover damages due to condensation. If the system return temperature does not fulfill the above requirements, it is necessary to increase the return temperature by using a mixing valve and/or a recirculation pump.

It is necessary to keep the burner switch always switched on in order to maintain water temperature equal approximately to the value set through the thermostat.

If the flue gas seal is poor in the front part of the boiler (manhole and burner plate) or the back part (smokebox), the closing tie rods of the individual parts must be adjusted; if this is not sufficient, the seals must be replaced.

CAUTION

Do not open the manhole and do not remove the smokebox while the burner is working. Always wait few minutes after the burner has been switched off until the insulating parts are cooler.

*For inspection purposes only.
Consent of copyright owner required for any other use.*

9 MAINTENANCE



IMPORTANT

Carry out thorough cleaning and periodic maintenance to ensure a correct and safe operation of the system. A perfectly clean tube bundle increases the thermal exchange between fumes and water contributing to energy saving and reducing air pollution.

9.1 PREPARATION FOR INSPECTION AND MAINTENANCE



Before carrying out any kind of maintenance, in order to avoid risks, the operator must be equipped with all the personal protection provided by the standards in force.



Before performing any cleaning and maintenance operation, it is first necessary to disconnect the device from both the fuel and the mains supply.

Maintenance must be entrusted only to **technically qualified personnel** and can be either mechanical or electrical.

The preparation and status of the generator may be different, depending on the operations to be performed:

- **With the boiler running**, to check the integrity of the generator when hot (fume trace seal, water side gasket seal, flue draught, operation of adjustment and safety accessories),
- **With switch-off and complete cooling** of the generator, when having to open the front door with inspection inside the furnace and fume chamber.
- **With cooling, complete emptying and safe shut-off of the generator** towards the system of use, in the case of water side internal visit.



Particular precautions must be taken to avoid the risk of electric shock since the system on the generator has accessories powered at 230V and/or at 400V.



Before intervening on the generator, ensure that the connection to the electrical system has been made according to current standards, also ensuring proper earthing connection to the system.

9.2 ORDINARY

- Carry out burner maintenance (as to the specific instructions) and have the calibration checked by duly qualified personnel.
- Check the tightness of flange bolts and the state of the gaskets;
- Analyse the system water and make sure it is treated in such a way that scaling does not occur, as scales would not only reduce the boiler performance, but also cause potentially fatal damage to the boiler in the long run.
- Make sure that refractory cladding and fume seal gaskets are intact; if they are not, replace them;
- Check the integrity of the flame warning light.
- Periodically clean the furnace (1) and the tube bundle (2) using a brush.
- Check the integrity and cleanliness of the turbulators (3), if any; in general gaseous fuels should not produce any carbon deposit while with the use of liquid fuels, it is necessary to clean frequently to avoid substantial fouling.
- To clean more thoroughly, the smoke chamber is to be removed; in this way, carbon residues can be eliminated from the back.

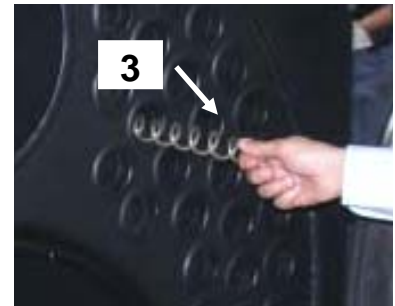
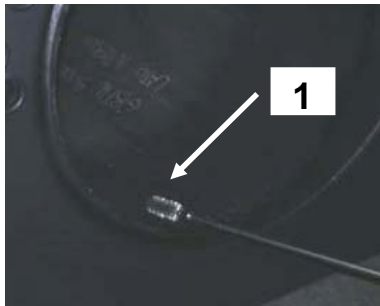

The above picture is only for reference

- Check the integrity of the electrical system on the generator.
- Check the integrity of the electrical panel, both outside (IP protection) and inside (check of all components inside the electrical panel).
- Periodically check the efficiency of adjusting and system safety tools.

10 QR CODE

HOW TO REGISTER YOUR BOILER

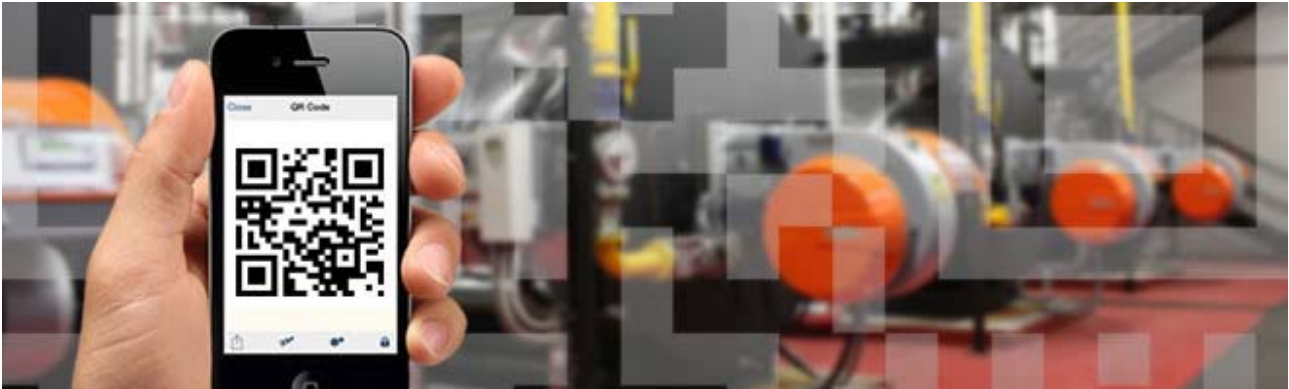

The boiler registration must be completed once the product is installed, either before or after the commissioning.

R107			
ICI CALDAIE S.p.A. Via G.Pascoli, 38 - 37059 ZEVIO (VR) - ITALIA -			
Tipo - Type - Typ - Modelos REX 400 EXP		Matricola - S/N - Matricule - Matricula 09437 200020871	
Codice - Code - Code - Codice 83819012			
CALDAIA PER RISCALDAMENTO - HEATING BOILER CHAUDIERE CHAUFFAGE - CALDERAPOR RISCALDAMIENTO			
PORTATA TERMICA - HEAT INPUT DEBIT THERM. - POTENC. TERM.		POTENZA UTILE - HEAT OUTPUT DEBIT THERM. UTILE - POTENCIA UTIL	
Q		P	
MAX	4333 kW 3,726,380 Kcal/h	MAX	4000 kW 3,440,000 Kcal/h
RISCALD. - HEATING - CHAUFFAGE - CALEFAC. TEMP. T 110 °C PRES. PMS 6 BAR		SANIT. - SAN.WATER - EAU SAN. - AGUA SAN. TEMP. °C PRES. BAR PROD. lt/min dT °C	
COMBUST. LIQUIDO - LIQUID FUEL GASOLIO - LIGHT OIL METANO - METHANE		GAS CATEG. V. CATEG. BRUC. TIPO - TYPE - TYP B23 GAS G20 (METANO-METHANE) 20 MBAR GAS G30-G31 (GPL-LPG) 28-30,57MBAR	
BRUCIAT. - BURNER - BRULEUR - QUEMADOR		V. 1/N- 230 ~	
ALIM.ELETT.-VOLTAGE-ALIM.ELECT.-TENSION D'ALIMENT.		Hz. 50	
		W. 20	
CLASSE PROT.-PROTECT.CLAS- CLASE DE PROC.-PROTEC.		IP40	
CLASSE NOx - NOx CLASS -			

The steps are as follows:

- 1) You only need a smartphone (iPhone, Samsung Galaxy, Htc, Blackberry etc.) or a tablet.
- 2) Download and install a "QR Reader" application on your device (a common free application will be sufficient). Open the program and point the camera on the QR code located on the label of the boiler (red circle in the picture).
- 3) You will be redirected on a web page where you can register the boiler and the plant data, filling the blank spaces.

Once completed the registration, it will be necessary to authenticate your email address following the link sent on your mail box.

You will receive a further email with username and password in order to have access to all the services that ICI has developed for those who register their boiler with the QR code.

The registration entitles you, also in the future, to enjoy promotions and specified services for the registered boiler (for example: discount for spare parts, free ordinary maintenance for some types of products etc.).

info at assistenza@icaldaie.com



alta tecnologia del calore

ICI CALDAIE SpA
Via G. Pascoli, 38
37059 Campagnola di Zevio VR

Telefono 045 8738511
Fax 045 8731148
Info@icialdaie.com
www.icialdaie.com

Partita Iva 00227490232
Rag. Soc. n. 6677
C.C.I.A.A. VR n. 69600

Appartenente al Gruppo Finluc
Iscritto R.I. VR 02245640236

DECLARATION OF CONFORMITY WITH THE EUROPEAN COMMUNITY REGULATIONS

I undersigned Emanuela Lucchini, Managing Director of ICI CALDAIE S.p.A.,
headquartered in via G. Pascoli 38 – 37059 Campagnola di Zevio (VR) Italy

DECLARE THAT STEEL BOILERS

**REX/REX F
REX K/REX K F
REX DUAL/REX DUAL F**

comply with the CE certificate and in accordance with the boards regulations:

- Gas Directive 2009/142/CE (Rif. EN 303)
- Low Voltage Directive 2014/35/UE
- Efficiency Directive 92/42/CEE
- EMC Directive 2014/30/UE

S. Maria di Zevio, li 04/08/2015

ICI CALDAIE S.p.A.
Direttore Generale
Emanuela Lucchini

*For inspection purposes only.
Consent of copyright owner required for any other use.*



Appartenente al Gruppo Finluc, iscritto R.I. VR n. 02245640236
Via G. Pascoli, 38 - 37059 Zevio - fraz. Campagnola - VERONA - ITALIA
Tel. 045/8738511 - Fax 045/8731148
info@icicaldaie.com - www.icicaldaie.com

The illustration and details reported are indicative only and are not binding. ICI CALDAIE reserves the right to introduce alterations and/or amendments as it deems fit and proper for the development of the product without the obligation of providing prior notice.