

# Attachment 2

For inspection purposes only.  
Consent of copyright owner required for any other use.

# MULTICAL® 402

## DATA SHEET

- Up to 16 years' battery lifetime
- Set/reset function
- Pulse outputs for energy and volume
- Pulse inputs for up to two water meters
- Wireless reading via Wireless M-Bus or radio

MID-2004/22/EC



PTB

22.52

05.04



## Compact meter for heat and cooling with maximum functionality

### Application

MULTICAL® 402 is the compact ultrasonic meter which registers the exact consumption due to its supreme measuring accuracy. The meter is maintenance-free and has a long lifetime which guarantees minimum yearly operating costs.

MULTICAL® 402 is used for heat, cooling and combined heat /cooling measurement in all water-based systems with temperatures from 2 to 160°C. The meter has been developed for measurement of energy consumption in family and multiple occupancy housing, housing associations, blocks of flats and small industry.

### Functionality

MULTICAL® 402 consists of calculator, flow sensor and two temperature

sensors and is simple to install, read and verify. Our flow sensor range for MULTICAL® 402 comprises of the sizes 0.6 – 15 m<sup>3</sup>/h, and the supply options are 230 or 24 VAC mains module, 2xAA-cell battery, or D-cell battery with up to 16 years' lifetime. MULTICAL® 402 is fitted with a connector for the supply and thus, it is easy to change battery or mains supply.

By means of the calculator's two front keys it is easy to adjust date and time or reset operating hour counter and info-event counter. Furthermore, the keys can be used to display log data, incl. yearly or monthly logger.

MULTICAL® 402 receives pulses from up to two connected hot or cold water meters and carries out remote accumulation of energy and volume via pulse outputs. If you change from

pulse input to pulse output, the meter is automatically configured for pulse inputs and pulse outputs respectively – without manual reconfiguration.

### Wireless reading

The meter is remotely read via Wireless M-Bus or radio module. Consumption data is read, saved and transferred by means of the USB Meter Reader. Furthermore, radio can be read by means of a hand-held terminal or form part of a Kamstrup radio network. The transferred data is used for individual billing, consumption analysis and/or energy optimisation.



# MULTICAL® 402

## DATA SHEET



## Content

---

Calculator functions	3
Pulse outputs and pulse inputs of the modules	7
Cabinet design	8
Approved meter data	9
Electrical data	10
Mechanical data	12
Materials	13
Accuracy	14
Dimensional sketches	16
Pressure loss	19
Accessories	20

*For inspection purposes only.  
Consent of copyright owner required for any other use.*

# MULTICAL® 402

## DATA SHEET



## Calculator functions

### Energy calculation

MULTICAL® 402 calculates energy based on the formula in EN 1434-1:2004, in which the international temperature scale from 1990 (ITS-90) and the pressure definition of 16 bar is used.

The energy calculation can in a simplified way be expressed as:  
 Energy =  $V \times \Delta\theta \times k$ .

V is the supplied water volume

$\Delta\theta$  is the temperature difference measured

k is the thermal coefficient of water

The calculator always calculates energy in [Wh], and then it is converted into the selected measuring unit.



E [Wh] =	$V \times \Delta\theta \times k \times 1000$
E [kWh] =	$E [\text{Wh}] / 1,000$
E [MWh] =	$E [\text{Wh}] / 1,000,000$
E [GJ] =	$E [\text{Wh}] / 277,780$
E [Gcal] =	$E [\text{Wh}] / 1,163,100$

### Application types

MULTICAL® 402 operates with four different energy formulas, E1...E9, that are all calculated in parallel in connection with each integration no matter how the meter is configured.

The four energy types are calculated as follows:

E1= $V1(T1-T2)k$  Heat energy (V1 in flow or return)

E3= $V1(T2-T1)k$  Cooling energy (V1 in flow or return)

E8= $m^3 \times T1$  (Flow pipe)

E9= $m^3 \times T2$  (Return pipe)

This renders MULTICAL® 402 capable of calculating the heat and cooling energy of most applications, both closed and open systems.

All energy types are data logged and can be displayed in-dependent of configuration.

### Flow measurement

MULTICAL® 402 calculates current water flow every 12 seconds or every 4 seconds depending on configuration.



### Power measurement

MULTICAL® 402 calculates current power on the basis of current water flow and the temperature difference measured in connection with the latest integration.

Current power is updated in the display every 24 seconds or every 4 seconds depending on configuration.

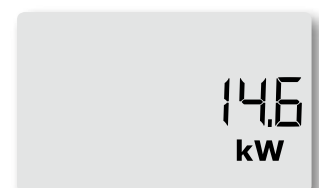

# MULTICAL® 402

## DATA SHEET



### Calculator functions

#### Min. and max. flow and power

MULTICAL® 402 registers minimum and maximum flow and power on a monthly as well as on a yearly basis. The registrations which can be read via data communication include max. and min. flow and power values, all with date indication.

All max. and min. values are calculated as largest and smallest average respectively of a number of current flow or power measurements. The average period used for all calculations is selected in the interval 1...1440 min.



#### Temperature measurement

MULTICAL® 402 is available in different versions for either Pt100 or Pt500 sensors in a 2-wire version.

The measuring circuit includes a high resolution analog/digital converter with a temperature range of 0,00°C...165,00°C.

In addition to current temperatures for the energy calculation average temperatures on a yearly and monthly basis can also be displayed.

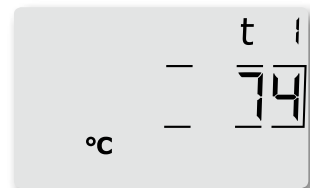

#### Display functions

MULTICAL® 402 is equipped with a clear LC display including 8 digits, units of measurement and information panel. In connection with energy and volume readings 7 digits and the units of measurement to match are used, whereas 8 digits are used when e.g. meter number is read.

As a starting point the display shows accumulated energy. When the push buttons are activated the display reacts immediately by calling other readings. The display automatically returns to accumulated energy reading 4 minutes after the latest activation of the push buttons.

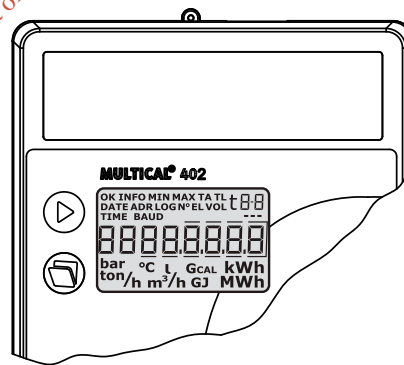

*The upper push button is used to switch between the primary readings. The consumers typically use the first primary readings in connection with self-reading for billing purposes.*

*The lower push button is used to show secondary information on the selected primary reading.*

# MULTICAL® 402

## DATA SHEET



## Calculator functions

### Set/reset function

The set/reset function of MULTICAL® 402 makes it possible to change a number of parameters by means of the two buttons on the meter's front.

The following parameters can be changed:

- Date
- Hour
- Input A (preset of register)
- Input B (preset of register)
- Meter no. of Input A
- Meter no. of Input B
- Primary M-Bus address
- Operating hour counter (reset)
- Info-event counter (reset)

As the installation seal is broken, the change can only be made by the energy supplier.

### Info codes

MULTICAL® 402 constantly monitors a number of important functions, e.g. power supply, temperature sensors and leakage alarms. Should a serious error occur in the measuring system or in the installation, a flashing "INFO" will appear in the display whilst the error exists. The "INFO" panel will automatically disappear when the error has been corrected.

An Info Event Logger indicates how many times the info code has been changed.

The info logger stores the latest 50 changes, of which 36 can be displayed.

Info code	Description	Response time
0	No irregularities	-
1	Supply voltage has been cut off	-
4	T2 sensor outside range, short-circuited or cut off	< 30 sec.
8	T1 sensor outside range, short-circuited or cut off	< 30 sec.
4096	Flow sensor with weak signal or air	< 30 sec.
16384	Flow sensor with wrong flow direction	< 30 sec.

# MULTICAL® 402

## DATA SHEET



## Calculator functions

### Data loggers

MULTICAL® 402 contains a permanent memory (EEPROM), where the results of a number of various data loggers are stored.

The meter contains the following data loggers:

Data logging interval	Data logging depth	Logged value
Yearly logger	15 years	Counter (as seen on the display)
Monthly logger	36 months	Counter (as seen on the display)
Daily logger	460 days	Consumption (increase)/day
Info logger	50 events (36 events can be shown in the display)	Info code and date

### Voltage supply

MULTICAL® 402 is available with 2 x AA battery supply (up to a lifetime of 6 years), D-cell battery (up to a lifetime of 16 years incl. Wireless M-Bus), 230 VAC mains module or 24 VAC mains module. The supply modules are exchangeable without breaking the verification seal.

### Plug-in modules

Plug-in modules can be added to MULTICAL® 402 such as

- Data
- M-Bus
- Wireless M-Bus
- Radio

In this way the meter can adapt to various applications and data reading methods.

### Programming and verification

METERTOOL for MULTICAL® 402 is a Windows® -based software which includes all facilities for calculator programming. If the software is used together with VERIFICATION EQUIPMENT for MULTICAL® 402, the calculator can be tested and verified.

# MULTICAL® 402

## DATA SHEET



## Calculator functions

### Tariff functions

MULTICAL® 402 has 2 extra registers TA2 and TA3 to accumulate energy parallelly to the main register based on a programmed tariff condition. No matter which tariff type you select the tariff registers will be displayed as TA2 and TA3.

The main register is always accumulated, irrespective of the selected tariff function, as it is considered the legal billing register.

Tariff conditions TL2 and TL3 are monitored before each integration. If the tariff conditions are fulfilled, the consumed heat energy is accumulated in either TA2 or TA3, as well as the main register.



## Pulse outputs and pulse inputs of the modules

### Pulse outputs CE and CV

MULTICAL® 402 has pulse outputs for energy and volume pulses respectively. CE on terminals 16-17 releases one pulse per least significant digit of the energy count in the display and CV on terminals 18-19 releases one pulse per least significant digit of the volume count in the display.

If a higher resolution of pulse outputs is required, a CCC code with high resolution must be selected.

### Pulse inputs VA and VB

MULTICAL® 402 has two extra pulse inputs, VA and VB, to collect and accumulate pulses remotely, e.g from cold-water meters and electricity meters. The pulse inputs are physically placed on the plug-in modules.

The pulse inputs VA and VB function independently of the other inputs/outputs.





# MULTICAL<sup>®</sup> 402

DATA SHEET



## Cabinet design

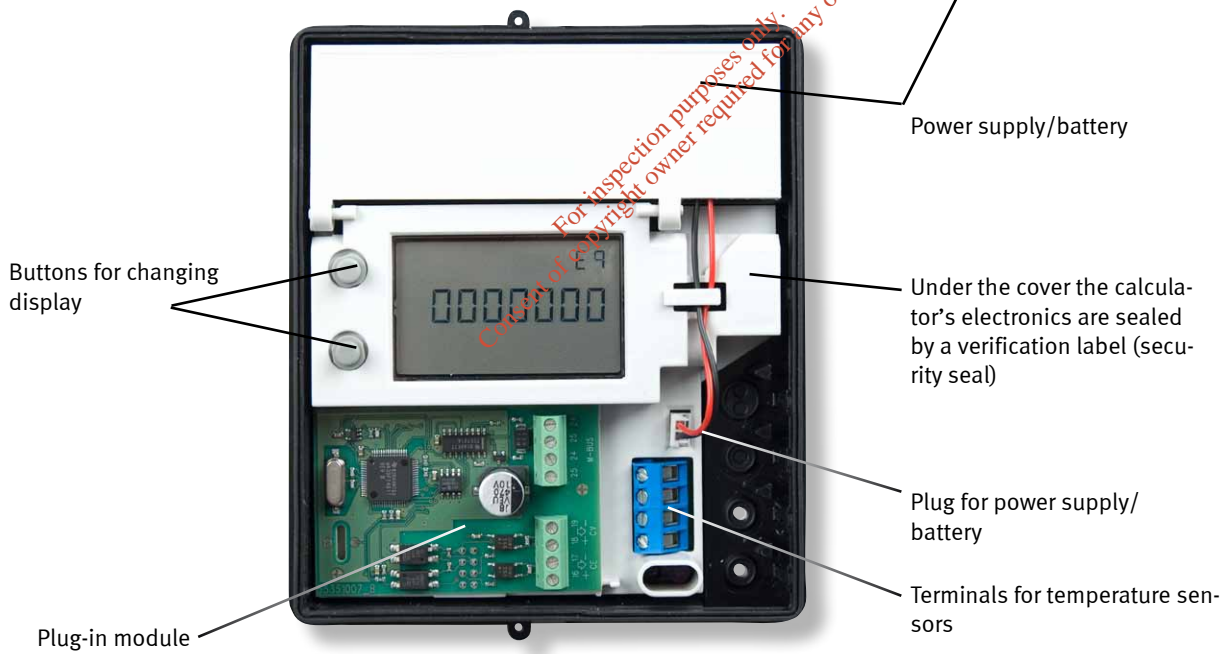

# MULTICAL® 402

## DATA SHEET



### Approved meter data

#### EU directives

- Measuring Instrument Directive
- Low Voltage Directive
- Electromagnetic Compatibility Directive
- Pressurised Equipment Directive

Standard prEN 1434:2009

#### Heat meter

- Approval DK-0200-MI004-013
- Temperature range  $\theta$ : 2°C...160°C
- Differential range  $\Delta\theta$ : 3K...150K

#### Cooling meter

- Temperature range  $\theta$ : 2°C...50°C
- Differential range  $\Delta\theta$ : 3K...30K

Accuracy  $E_c \pm (0,5 + \Delta\theta_{min} / \Delta\theta) \%$

#### Temperature sensors

- Type 402-V Pt100 – EN 60 751, 2-wire connection
- Type 402-W/T Pt500 – EN 60 751, 2-wire connection

EN 1434 designation Environmental class A

#### MID designation

- Mechanical environment class M1
- Electromagnetic environment class E1

Non condensing, closed location (indoor installation), 5...55°C

The stated minimum temperatures apply to the type approval only. The meter has no cutoff for low temperature and thus measures as low temperatures as 0.01°C and 0.01 K.

Type number	Nom. flow qp [m³/h]	Max. flow qs [m³/h]	Min. flow qi [l/h]	Min. cut off [l/h]	Pressure loss $\Delta p @ qp$ [bar]	Connection meter	Length [mm]
402xxxxx1xxx	0.6	1.2	6	3	0.04	G¾B	110
402xxxxx3xxx	0.6	1.2	6	3	0.04	G1B	190
402xxxxx4xxx	1.5	3.0	15	3	0.25	G¾B	110
402xxxxx5xxx	1.5	3.0	15	3	0.25	G¾B	165
402xxxxx7xxx	1.5	3.0	15	3	0.25	G1B	130
402xxxxx9xxx	1.5	3.0	15	3	0.25	G1B	190
402xxxxxAxxx	2.5	5.0	25	5	0.03	G1B	130
402xxxxxBxxx	2.5	5.0	25	5	0.03	G1B	190
402xxxxxDxxx	3.5	7.0	35	7	0.07	G5/4B	260
402xxxxxFxxx	6.0	12	60	12	0.19	G5/4B	260
402xxxxxGxxx	6.0	12	60	12	0.19	DN25	260
402xxxxxHxxx	10	20	100	20	0.06	G2B	300
402xxxxxJxxx	10	20	100	20	0.06	DN40	300
402xxxxxKxxx	15	30	150	30	0.14	DN50	270

# MULTICAL<sup>®</sup> 402

## DATA SHEET



## Electrical data

### Calculator data

Typical accuracy

– Calculator

$$E_c \pm (0.15 + 2/\Delta\Theta)\%$$

– Sensor set

$$E_T \pm (0.4 + 4/\Delta\Theta)\%$$

Display

LCD – 7 (8) digits with a digit height of 7.6 mm

Resolution

9999.999 – 99999.99 – 999999.9 – 9999999

Energy units

MWh – kWh – GJ – Gcal

Data logger (Eeprom)

460 days, 36 months, 15 years, 50 info codes

Clock/calendar

Clock, calendar, leap-year compensation, target date

Data communication

KMP protocol with CRC16 used for optical communication and for base modules

Power in temperature sensors

< 10  $\mu$ W RMS

### Supply voltage

3.6 VDC  $\pm$  0.1 VDC

### Battery

Replacement interval	3.65 VDC, D-celle lithium	3.65 VDC, 2xAA cell lithium
Mounted on wall	16 years @ $t_{BAT} < 30^\circ\text{C}$	6 years @ $t_{BAT} < 30^\circ\text{C}$
Mounted on the flow sensor	12 years @ $t_{BAT} < 40^\circ\text{C}$	5 years @ $t_{BAT} < 40^\circ\text{C}$

The replacement interval is reduced by using data modules, at frequent data communication and at high ambient temperature.

### Mains supply

230 VAC  $\pm$ 15/-30%, 50/60 Hz

24 VAC  $\pm$ 50%, 50/60 Hz

Insulation voltage

4 kV

Power supply

< 1 W

Back-up supply

Integral super-cap eliminates operational stop-down due to short-term power cuts.

EMC data

Meets EN 1434 class A (MID class E1)

# MULTICAL® 402

## DATA SHEET



## Electrical data

### Temperature measurement

		T1 Flow temperature	T2 Return temperature	$\Delta\Theta(T1-T2)$ Heat metering	$\Delta\Theta(T2-T1)$ Cooling metering
<b>402-V 2-W Pt100</b>	Measuring range	0.00...165.00°C	0.00...165.00°C	0.01...165.00K	0.01...165.00K
<b>402-W/T 2-W Pt500</b>	Measuring range	0.00...165.00°C	0.00...165.00°C	0.01...165.00K	0.01...165.00K

<b>Pulse inputs VA and VB VA: 65-66 and VB: 67-68 via module</b>	<b>Water meter connection FF(VA) and GG(VB) = 01...40</b>
Pulse input	680 k $\Omega$ pull-up to 3.6 V
Pulse ON	$\geq 0.4$ V for $> 30$ msec.
Pulse OFF	$> 2.5$ V for $> 1.1$ sec.
Pulse frequency	$< 0.5$ Hz
Electrical isolation	No
Max. cable length	25 m
Requirements to external contact	Leakage current at function open $< 1 \mu\text{A}$

<b>Pulse outputs CE and CV Energy (16-17) Volume (18-19) via module</b>	<b>The pulse outputs can be configured for heat or cooling energy</b>
Type	Open collector (OB)
Pulse length	Programmable 32 msec. or 100 msec.
External voltage	5...30 VDC
Current	1...10 mA
Residual voltage	$U_{CE} \approx 1$ V at 10 mA
Electrical isolation	2 kV
Max. cable length	25 m

# MULTICAL® 402

## DATA SHEET



### Mechanical data

Environment class	Meets EN 1434 class A (MID class E1)
Ambient temperature	5...55°C, non condensing, closed location (indoor installation)
Protection class	
– Calculator	IP54
– Flow sensor	IP65
<b>Media temperature</b>	
– Heat meters	402-V/W: 15...130°C
– Cooling meters	402-T: 2...50°C
– Heat/Cooling meters	402-T: 2...130°C
– Media in flow sensor	Water
Storage temperature	-20...60°C (drained flow meter)
Pressure step (with thread)	PN16
Pressure step (with flanges)	PN25
Weight	From 1.8 to 12 kg depending on the size of the flowpart
Flow sensor cable	1.5 m (the cable cannot be removed)
Connection cables	ø3.5...6 mm
Supply cable	ø5...10 mm

At medium temperatures over 90°C in the flow sensor, we recommend using flange meters and mounting the calculator on the wall.

For inspection purposes only.  
Consent of copyright owner required for any other use.

# MULTICAL® 402

## DATA SHEET



## Materials

---

### Wetted parts

Housing, gland	DZR brass (dezincification resistant)
Housing, flange	Stainless steel, W.no. 1.408
Transducers	AISI 316
Gaskets	EPDM
Measuring pipe	PES 30% GF
Reflectors	AISI 304

### Flow sensor housing

Top/wall brackets	PC + 20% glass
-------------------	----------------

### Calculator casing

Top cover	PC
Base unit	ABS with TPE gaskets (thermoplastic elastomer)
Internal cover	ABS
Flow sensor cable	Silicone cable with internal teflon insulation

For inspection purposes only  
Consent of copyright owner required for any other use

# MULTICAL® 402

## DATA SHEET



### Accuracy

Sub-units of the heat meter	MPE according to EN 1434-1	MULTICAL® 402, typical accuracy
Flow sensor	$E_f = \pm(2 + 0.02 \text{ qp}/q) \%$	$E_f = \pm(1 + 0.01 \text{ qp}/q) \%$
Calculator	$E_c = \pm(0.5 + \Delta\Theta_{\min}/\Delta\Theta) \%$	$E_c = \pm(0.15 + 2/\Delta\Theta) \%$
Sensor set	$E_t = \pm(0.5 + 3\Delta\Theta_{\min}/\Delta\Theta) \%$	$E_t = \pm(0.4 + 4/\Delta\Theta) \%$

MULTICAL® 402  $q_p$  1.5 m<sup>3</sup>/h @  $\Delta\Theta$  30K

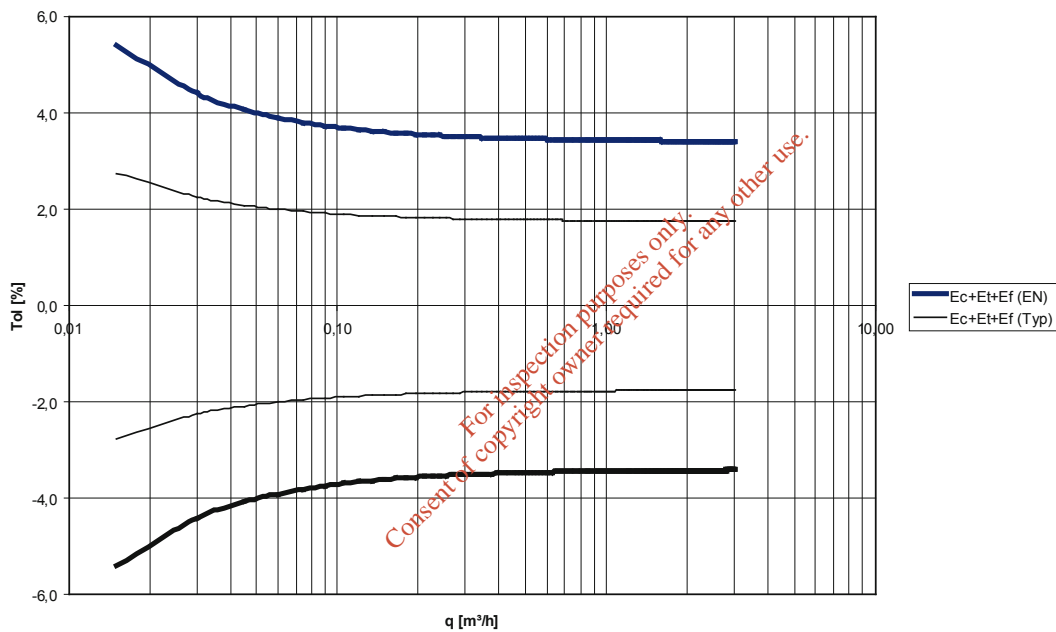

# MULTICAL® 402

## DATA SHEET



### Order specifications

MULTICAL® 402	Type 402	<input type="checkbox"/>	<input type="checkbox"/>	<input type="checkbox"/>	<input type="checkbox"/>	<input type="checkbox"/>	<input type="checkbox"/>	<input type="checkbox"/>	<input type="checkbox"/>
<b>Sensor connection</b>									
Pt100	V								
Pt500	W								
Pt500 (with condensation protected flow sensor for cooling)	T								
<b>Modules</b>									
No module			00						
Data + 2 pulse inputs (VA, VB)			10						
Data + 2 pulse outputs (CE, CV)			11						
M-Bus + 2 pulse inputs (VA, VB)			20						
M-Bus + 2 pulse outputs (CE, CV)			21						
Wireless M-Bus, EU, 868 MHz, Mode C1			30						
Radio, EU, 434 MHz, int. ant., NET0			40						
Radio, EU, 434 MHz, int. ant., NET1			41						
Radio, EU, 434 MHz, int.+ext. ant., NET0 + 2 pulse inputs (VA, VB)			42						
Radio, EU, 434 MHz, int.+ext. ant., NET0 + 2 pulse outputs (CE, CV)			43						
Radio, EU, 434 MHz, int.+ext. ant., NET1 + 2 pulse inputs (VA, VB)			44						
Radio, EU, 434 MHz, int.+ext. ant., NET1 + 2 pulse outputs (CE, CV)			45						
Radio, SE, 444 MHz, int. ant., NET0 + 2 pulse inputs (VA, VB)			50						
Radio, SE, 444 MHz, int. ant., NET1 + 2 pulse inputs (VA, VB)			51						
Radio, SE, 444 MHz, ext. ant., NET0 + 2 pulse inputs (VA, VB)			54						
Radio, SE, 444 MHz, ext. ant., NET1 + 2 pulse inputs (VA, VB)			56						
<b>Supply</b>									
No module							0		
Battery, 2 x AA							1		
Battery, D-cell							2		
230 VAC supply module							7		
24 VAC supply module							8		
<b>Pt500 sensor set</b>									
No sensor set								00	
Pocket sensor set with 1.5 m cable								0A	
Pocket sensor set with 3.0 m cable								0B	
Short direct sensor set with 1.5 m cable								0F	
Short direct sensor set with 3.0 m cable								0G	
<b>Flow sensor</b>									
<b>qp [m³/h]</b>	<b>Connection</b>	<b>Length [mm]</b>							
0.6	G¾B (R½)	110						1	
0.6	G1B (R¾)	190						3	
1.5	G¾B (R½)	110						4	
1.5	G¾B (R½)	165						5	
1.5	G1B (R¾)	130						7	
1.5	G1B (R¾)	190						9	
2.5	G1B (R¾)	130						A	
2.5	G1B (R¾)	190						B	
3.5	G5/4B (R1)	260						D	
6.0	G5/4B (R1)	260						F	
6.0	DN25	260						G	
10	G2B (R1½)	300						H	
10	DN40	300						J	
15	DN50	270						K	
<b>Meter type</b>									
Heat meter (MID: module B+D)									2
Heat meter (MID: module B+D. Only MULTICAL® 402 T)									3
Heat meter									4
Cooling meter (only MULTICAL® 402 T)									5
Heat/cooling meter (only MULTICAL® 402 T)									6
<b>Country code (language on lable etc.)</b>									XX

Consent of copyright owner required for any other use.  
For inspection purposes only.



# MULTICAL® 402

## DATA SHEET



### Dimensional sketches

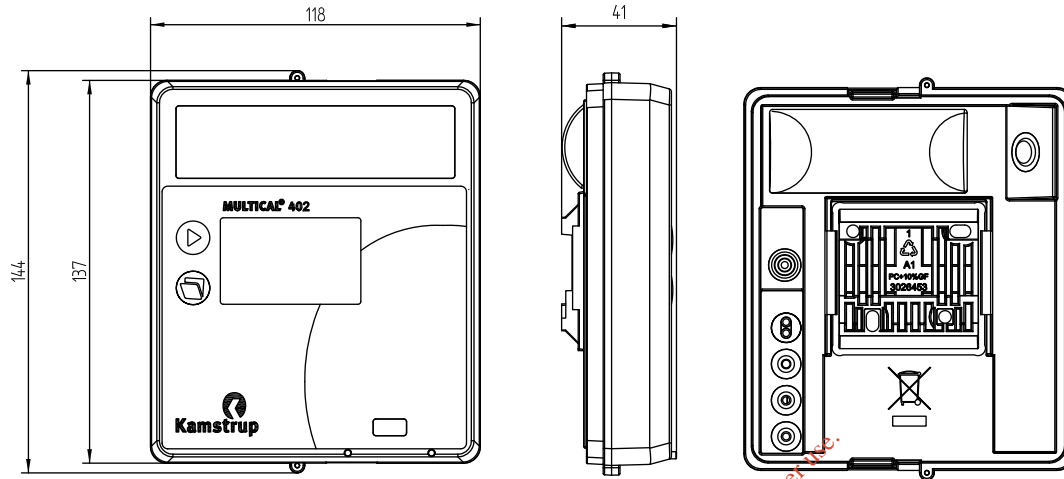

Mechanical measurements of the electronics unit

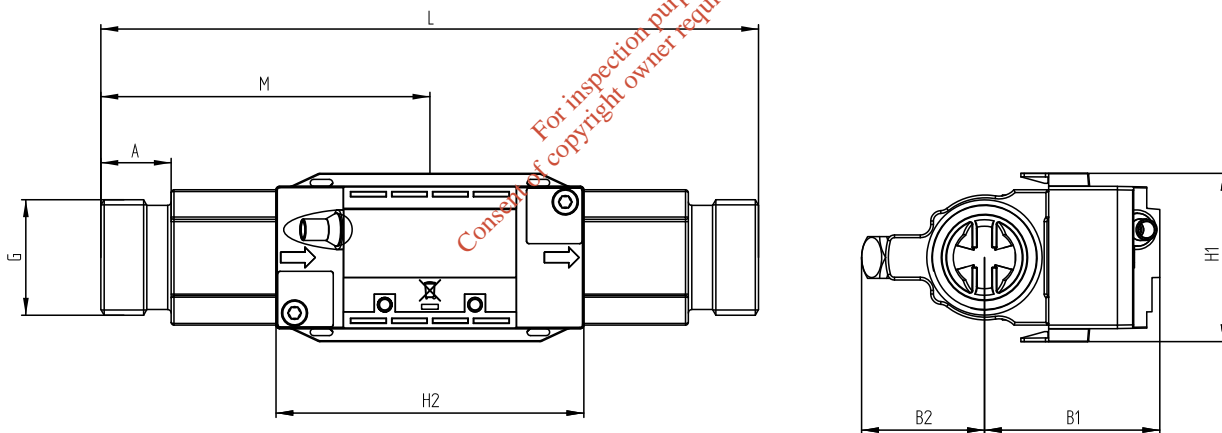

### Flow sensor with G<sup>3/4</sup> and G1 thread connection

Thread	L	M	H2	A	B1	B2	H1	Approx. weight [kg]
G <sup>3/4</sup>	110	L/2	89	10.5	50.5	35	48.5	1.4
G1 (qp 1.5)	130	L/2	89	20.5	50.5	35	48.5	1.5
G1 (qp 2.5)	130	L/2	89	20.5	50.5	35	48.5	1.4
G <sup>3/4</sup>	165	L/2	89	20.5	50.5	35	48.5	1.8
G1 (qp 1.5)	190	L/2	89	20.5	50.5	35	48.5	2.0
G1 (qp 2.5)	190	L/2	89	20.5	50.5	35	48.5	1.9

Weight includes a 3 m Short direct sensor set, but is excluding packing.

# MULTICAL® 402

## DATA SHEET



### Dimensional sketches

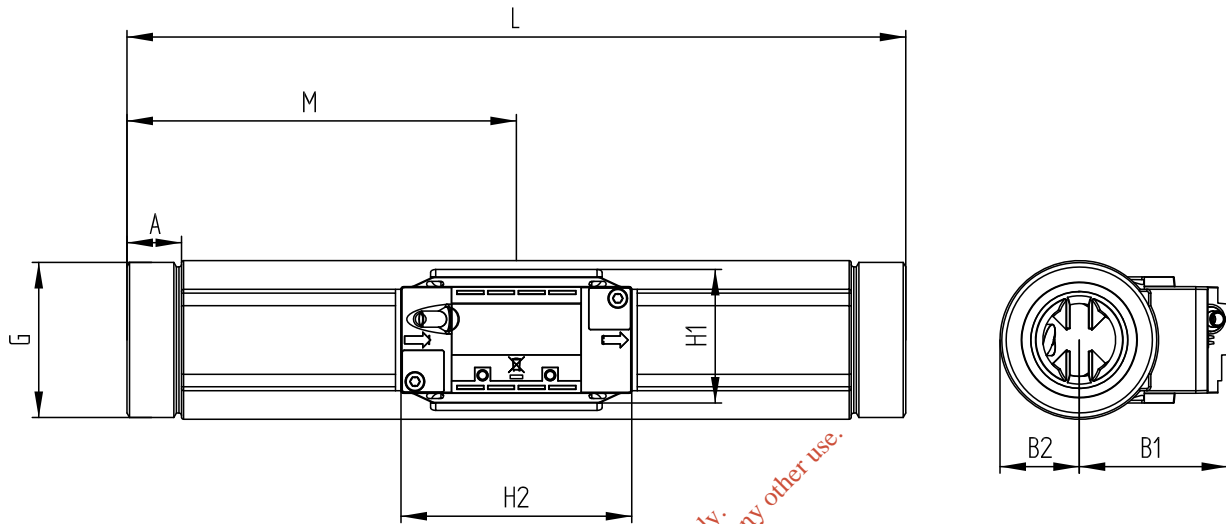

#### Flow sensor with G5/4 and G2 thread connection

Thread	L	M	H2	A	B1	B2	H1	Approx. weight [kg]
G5/4	260	L/2	88.7	17	50.5	22	48.5	2.9
G2	300	L/2	88.7	21	50.5	31	48.5	5.1

Weight includes a 3 m Short direct sensor set, but is excluding packing.

# MULTICAL® 402

## DATA SHEET



### Dimensional sketches

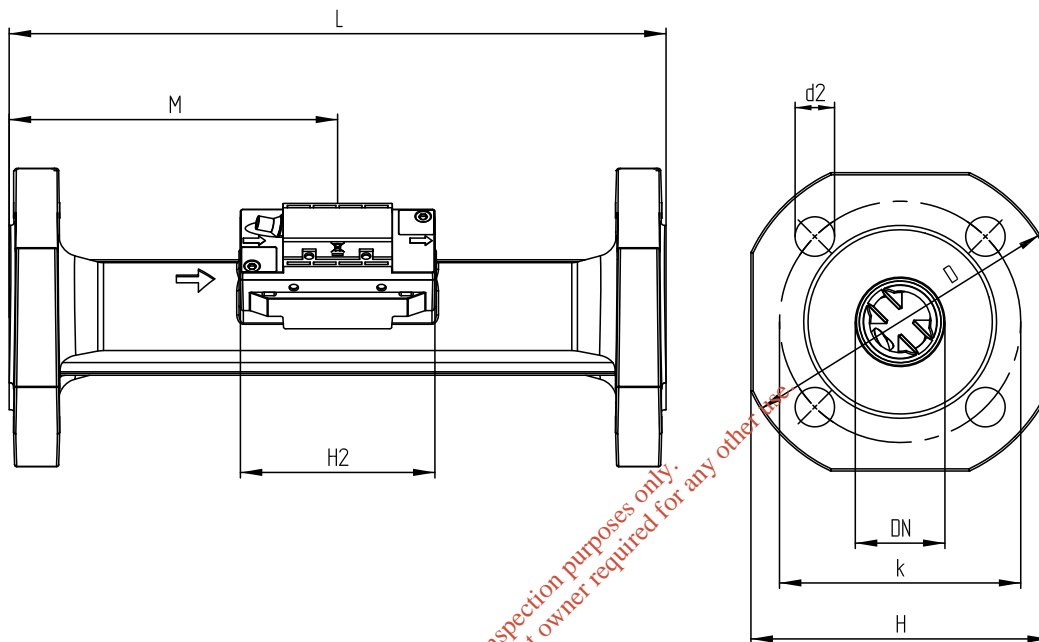

Flow sensor with DN25 to DN50 flange connection

Nom. diameter	L	M	H2	D	H	k	Bolts			Approx. weight [kg]
							Number	Thread	d2	
DN25	260	L/2	92.5	115	106	85	4	M12	14	5.6
DN40	300	L/2	92.5	150	136	110	4	M16	18	8.9
DN50	270	155	92.5	165	145	125	4	M16	18	10.7

Weight includes a 3 m short direct sensor set, but is excluding packing.

# MULTICAL® 402

## DATA SHEET



### Pressure loss

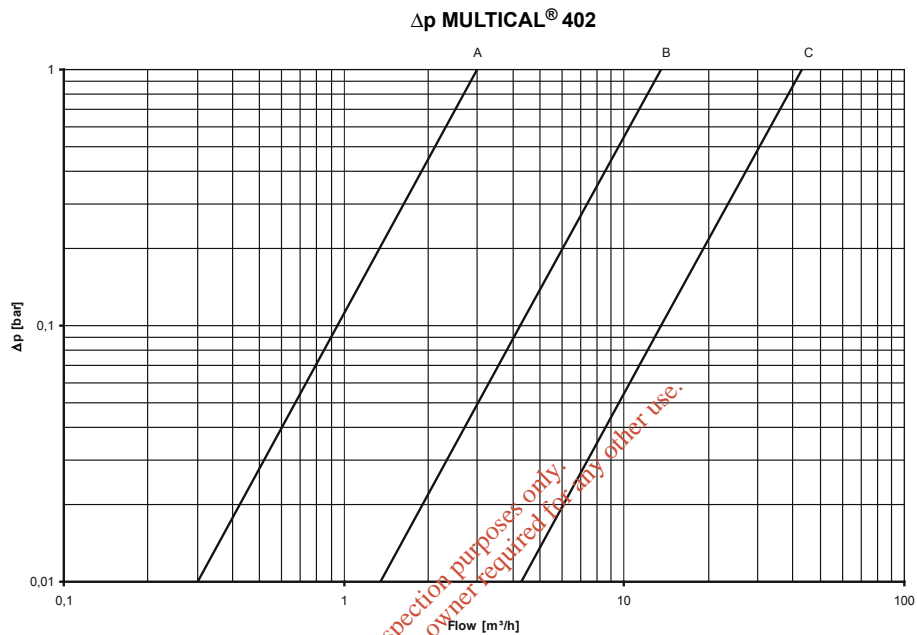

Graph	q <sub>0</sub> [m³/h]	Nom. diameter [mm]	kv	Q@0,25 bar [m³/h]
A	0.6 & 1.5	DN15 & DN20	3	1.5
B	2.5 & 3.5 & 6	DN20 & DN25	13.5	6.8
C	10 & 15	DN40 & DN50	43	21.7

# MULTICAL® 402

## DATA SHEET



## Accessories

Type number	Description
402-000-1000-000	Battery module 2 pcs. AA-cell
402-000-2000-000	D-cell battery
402-000-7000-000	230 VAC supply module
402-000-8000-000	24 VAC supply module
66-99-097	USB cable with galvanic separation
66-99-099	Infra-red optical reading head with USB plug
66-99-102	Infra-red optical reading head RS232 with D-sub 9F
66-99-106	Data cable RS232, D-sub 9F
66-99-108	Pc-Interface cable RS232 for MULTICAL®
66-99-372	Pt500 (Heat) Verification Equipment for MULTICAL® 402 (used with METERTOOL)
66-99-373	Pt500 (Cooling) Verification Equipment for MULTICAL® 402 (used with METERTOOL)
66-99-712	METERTOOL for MULTICAL® 402
66-99-713	METERTOOL LogView for MULTICAL® 402

### Glands including gaskets (PN16)

Size	Nipple	Union	Type No.	2 pcs
DN15	R $\frac{1}{2}$	G $\frac{3}{4}$		65-61-323
DN20	R $\frac{3}{4}$	G1		65-61-324
DN25	R1	G $\frac{5}{4}$	65-61-325	
DN40	R1 $\frac{1}{2}$	G2	65-61-315	

### Gaskets

For glands		For flange meters PN25	
Size (Union)	Type No.	Size	Type No.
G $\frac{3}{4}$	2210-061	DN20	2210-147
G1	2210-062	DN25	2210-133
G $\frac{5}{4}$	2210-063	DN40	2210-132
G2	2210-065	DN50	2210-099