

Environmental Licensing Programme,  
Office of Climate, Licensing & Resource Use,  
Environmental Protection Agency,  
Headquarters, P.O. Box 3000,  
Johnstown Castle Estate,  
Co. Wexford.

**For Attention of: Ms Yvonne English**

22<sup>nd</sup> April, 2013

**Re: Licensing Action - Reg 18(3)(b) Notice Sent – 3 for Drommahane  
Licence (D0302-01)**

---

A Chara,

I refer to correspondence issued on 11/04/2013 in relation to the above. The following addresses the queries which were raised.

#### **REGULATION 16 COMPLIANCE REQUIREMENTS**

**Question** *Provide details on any programme of improvements for the agglomeration. The details should include a timeframe for the completion of the improvement works*

**Answer** *There is currently no programme of improvements for the agglomeration.*

**Question** *Section G.1( Dangerous Substance Directive 2006/11/EC) makes reference to Buttevant. Should this statement refer to Drommahane?*

**Answer** *Yes, it should refer to Drommahane*

**Question** *Provide the effluent monitoring results for BOD, COD, suspended solids, orthophosphate and ammonia from the primary discharge in 2012*

**Answer** *Please see summary of effluent monitoring results below, and find attached copy of laboratory test report ( Appendix A). Effluent monitoring did not include results for orthophosphate and ammonia*

	BOD	COD	SS
	(mg/l)	(mg/l)	(mg/l)
04/04/2012	32	157	106
07/06/2012	2.8	26	3
06/09/2012	3.2	29	<2.5
12/09/2012	7.8	37	11
04/10/2012	11	36	13
06/11/2012	3.8	28	8

**Question** Clarify the design population (p.e) of the WWTP, the current p.e to the plant, the projected p.e to be contributed to the waste water works over the next six years, bearing in mind planning permission that has been granted for development but where development has not been completed to date, and provide the percentage p.e to be contributed by non domestic activities

**Answer** The design p.e of the plant is 1000 and was commissioned in 1998. The hydraulic loading to the plant in 2012 was 102,344 m<sup>3</sup>, giving a daily average of 280m<sup>3</sup>. At 225 litres per person per day, this gives a hydraulic p.e of 1244 for 2012. There is currently no uncompleted development in the agglomeration. There has been substantial residential development in the agglomeration in recent years, but this has been completed and It is not expected that there will be any additional p.e to be contributed to the waste water works over the next 6 year. It is estimated that 25 % of the p.e loading to the waste water works is from non-domestic sources, as there is a large nursing home in the agglomeration as well as schools, community facilities and public houses etc. It is expected that this will not change over the next 6 years..

**Question** Provide a revised drawing clearly detailing the boundary of the agglomeration to which this application relates. Please note that the agglomeration boundary shall include all areas serviced by the sewer network and shall include the waste water treatment plant. All areas of the agglomeration shall be within the agglomeration boundary.

**Answer** Please find attached copy of Drawing Title ' Agglomeration Boundary Attachment B1- Map4' Revision A dated April 2013 which incorporates a revision to the agglomeration boundary such that the site of the waste water treatment works is within the curtilage of the agglomeration boundary.(Appendix B).

**Question** Confirm the daily normal and daily maximum effluent volumes emitted from the primary discharge, expressed as m<sup>3</sup>/day.

**Answer**      *The normal daily average effluent discharge was measured as 280m<sup>3</sup>/day in 2012. In times of rainfall discharges would be greater than this depending on the intensity and duration of the rainfall event, in 2012 the maximum daily volume was 934m<sup>3</sup> recorded on 24<sup>th</sup> December 2012.*

**Question**    ***The application states that an automatic screen was due to be installed at waste water treatment plant in 2009, has this work been completed.***

**Answer**      Yes.

A revised non-technical summary which reflects information supplied in compliance with the notice is attached as Appendix C

The following is a list of the drawings revised as a result of the request

<b>Drawing No.</b>	<b>Drawing Title.</b>	<b>Revision.</b>
A1 – Map 1	Location Map Scale 1:50,000 Attachment A1 – Map 1	
A1 – Map 2	Site Locations of WWTP Attachment A1 – Map 2	-
A1 – Map 3	Waste Water Treatment Plant Site Layout Attachment A1 – Map 3	-
B1 – Map 4	Agglomeration Boundary Attachment B1 – Map 4	A
B2 – Map 5	Wastewater Treatment Plant Site Layout Attachment B2 – Map 5	A
B3 – Map 6	Location of Primary Discharge Point SW01 – BALY Attachment B3 – Map 6	A
B3 – Map 7	Locations of Sampling Points Attachment B3 – Map 7	-
B8 – Map 8	Location of Site Notice Attachment B8 – Map 8	-
C1 – Map 9	Wastewater Treatment Plant Site Layout Attachment C1 – Map 9	A
C1- Drawing 1	Schematic showing Existing Treatment Plant Process Attachment C1 – Drawing 1	A

Is mise le meas,

---

Pat Britton  
Executive Engineer,  
Waste Water Pumping & Treatment Zone 4,  
WATER SERVICES DIRECTORATE

Direct Tel: 022-54808  
Email: pat.britton@corkcoco.ie

*For inspection purposes only.  
Consent of copyright owner required for any other use.*

**APPENDIX A**

**Laboratory Test Report**

*For inspection purposes only.  
Consent of copyright owner required for any other use.*



# Laboratory Test Report

## Cork County Council

### Waste Water Laboratory

#### Inniscarra, Co. Cork

March 7, 2013

Industry Name Dromahane STP  
 Address Dromahane,  
 mallow,  
 Co. Cork

Industry Code No. 353  
 Report Ref No. X070313-090  
 Issued to B. O'Sullivan  
SEE  
CC

Licence No. Type S

Licence	Volume m3	pH	B.O.D. mg/l	C.O.D. mg/l	S.Solids mg/l	TP-P mg/l	Code	Comments
Limit	999999	12.99 3.99	25	125	35	99		
Date								
04/04/12			* 32	* 157	* 106		GW207	G
07/06/12	548		2.8	26	3		GW441	C
06/09/12			3.2	29	<2.5		GW825	G
12/09/12			7.8	37	11		Gw875	G
04/10/12			11	36	13		GW908	G
06/11/12			3.8	25	8		GW1090	G
% Compl.	100	***	83	83	83	***		
Average	548.00	**** **	10.10	51.67	23.50	**** **		

Consent of copyright owner required for any other use.

The samples are received at the Laboratory on the day of sampling. The above test methods are based on Standard Methods for the examination of Water and Waste Water, 21st Edition 2005, APHA, AWWA, WEF. C = Composite Sample, G = Grab Sample.

The compliance value may be varied on items marked with an \* by the application of uncertainty of measurement values on reverse Page Chemical Procedure Numbers(CP No.) for INAB accredited tests are as follows:

- CP NO. 1 = B.O.D.
- CP NO. 3 = S.S.
- CP NO. 20 = TP-P
- CP NO. 5 = pH
- CP NO. 6 = C.O.D.
- CP NO. 22 = Ammonia(KONELAB)
- CP NO. 23 = OPO4-P(KONELAB)
- CP NO. 24 = Chloride (KONELAB)
- CP NO. 25 = Sulphate(KONELAB)

This report relates only to the samples listed above. This report shall not be reproduced except in full and only with the approval of the testing laboratory. Cork County Council is not accredited by INAB for tests marked with \$. Kg loadings based on flows as supplied by the company. ~ indicates results that have been edited.

Reported by: V. Hannon Date: 7/3/13

Ms. V. Hannon  Technical Manager  
 Deputy Technical Manager

CTR 001 Issue No 26 ~~November 2007~~ October 2008 COH 7/3/13

**APPENDIX B**

**Revised Drawing(s)**

*For inspection purposes only.  
Consent of copyright owner required for any other use.*

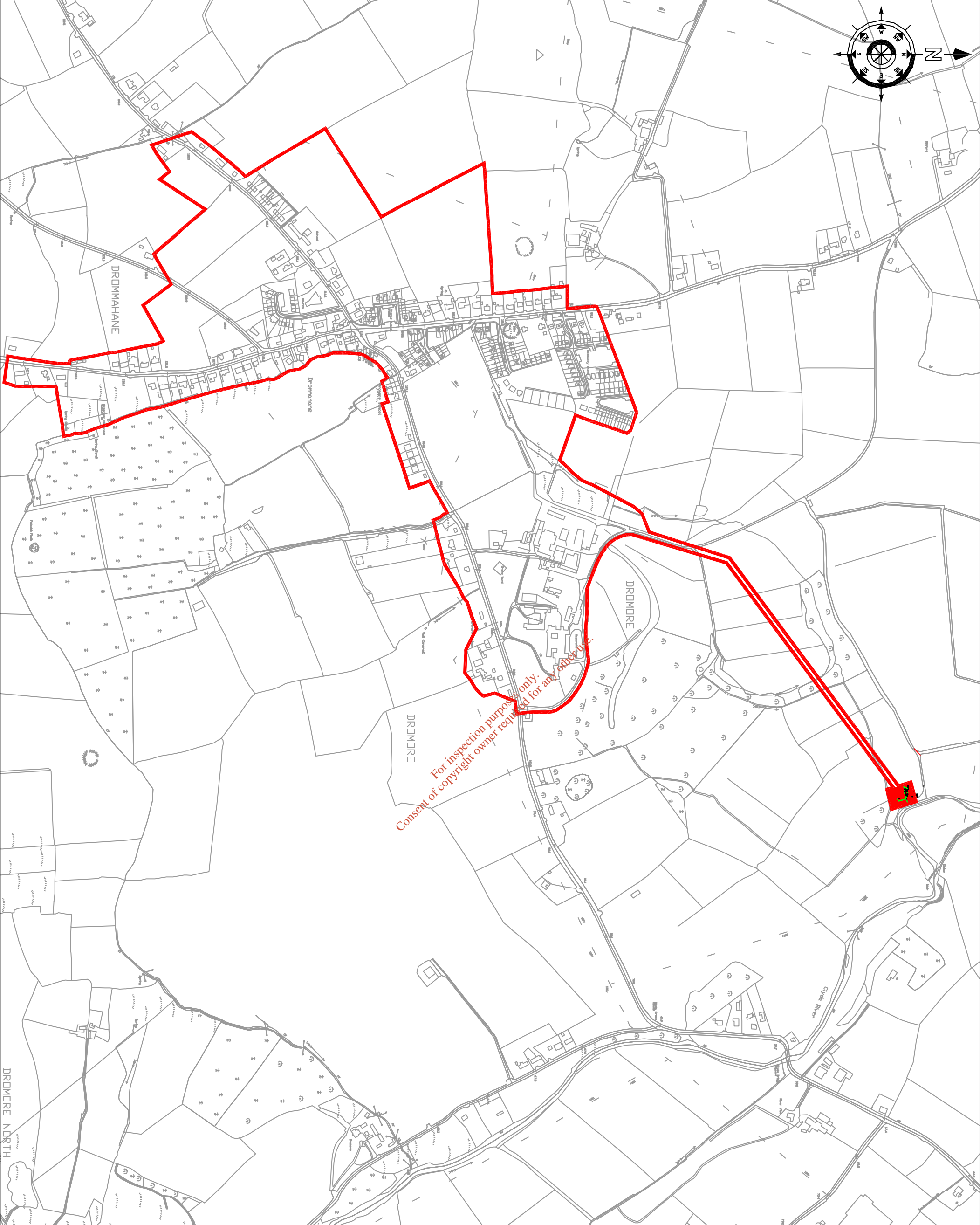
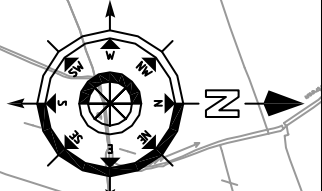

**NOTES**

1. Dimensions are not to be scaled from drawing. For any discrepancies found consult with the design office.
2. This drawing is to be read in conjunction with the Specification.
3. This drawing is to be read in conjunction with all other contract drawings.

No.	Date	Drawn/Checked	Revision Description
A	04/13	DL	BIS Change to agglomeration boundary

**Cork County Council,**  
Northern Division.



N. O'KEEFE, B.E.,  
A/COUNTY ENGINEER,  
COUNTY HALL,  
CDRJK.

**Job Title:**  
Dromahane & Environs  
Wastewater Discharge  
Licence Application

**Drawing Title:**  
Agglomeration Boundary  
Attachment B1 - Map 4

Scopes	Drawn by	Checked by	Date
NTS	DL	F.C.	August 2008

Designed by	Checked by	Date
F.J.	F.C.	August 2008

Drawing number	Rev.
B1 - Map 4	A



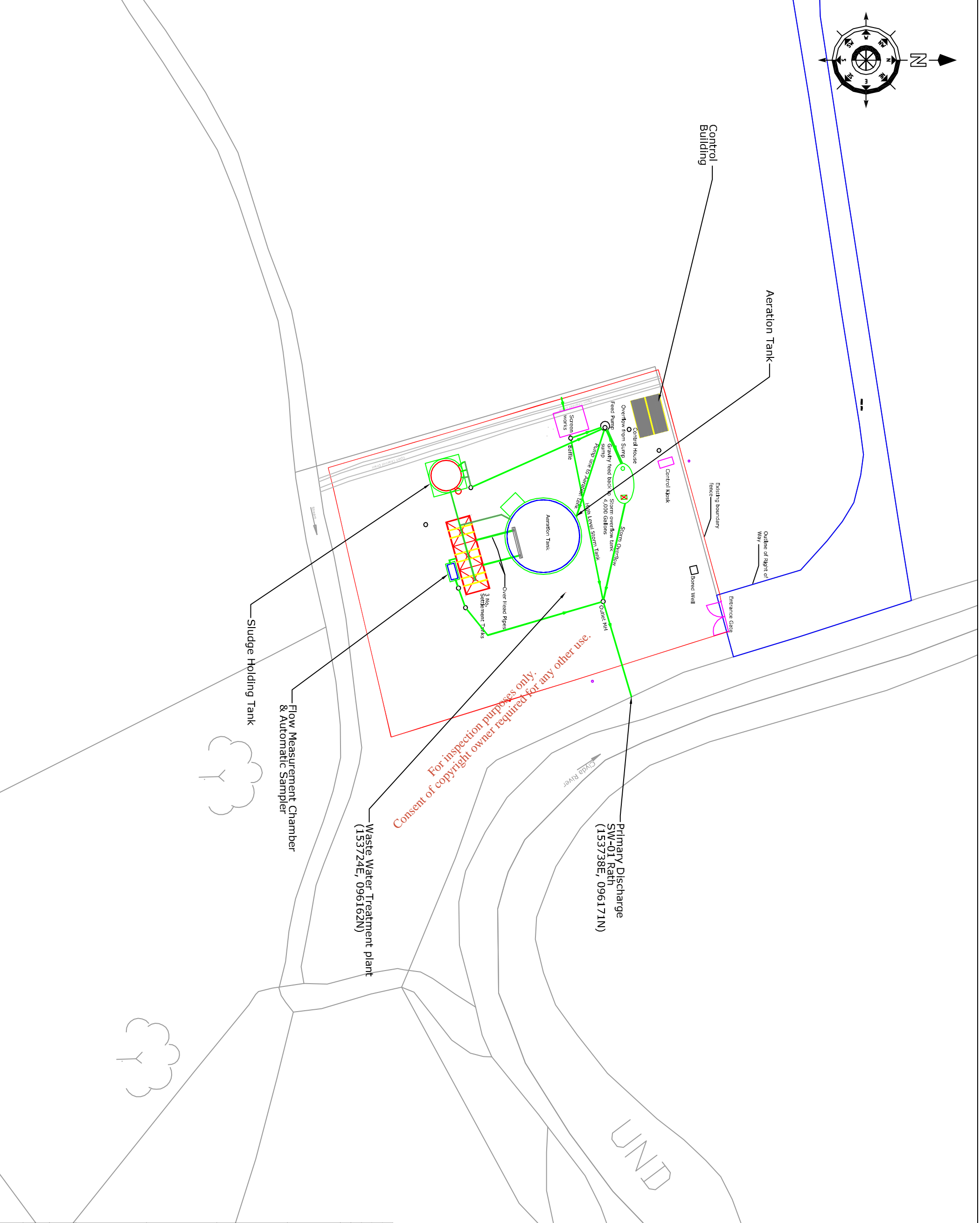
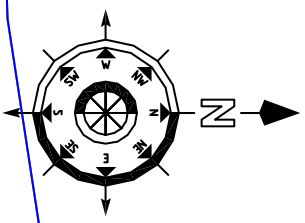

**NOTES**

1. Dimensions are not to be scaled from drawing. For any discrepancies found consult with the design office.
2. This drawing is to be read in conjunction with the Specification.
3. This drawing is to be read in conjunction with all other contract drawings.

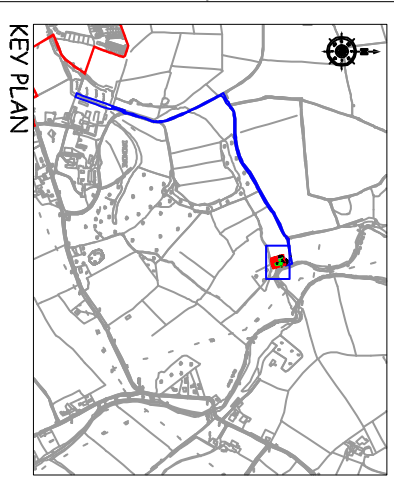

No.	Date	Drawn/Checked	Revision Description
A	04/13	DL	DL
		PB	Revised wastewater treatment plant layout

Cork County Council,  
Northern Division.



N. O'KEEFE, B.E.,  
A/COUNTY ENGINEER,  
COUNTY HALL,  
CDRJK.

**Job Title:**  
Dromahaire & Environs  
Wastewater Discharge  
Licence Application

**Drawing Title:**  
Location of Waste Water  
Treatment Plant  
Attachment B2 - Map 5

Scale:	Surveyed by:	Drawn by:
1:500 @ A3	D.L.	D.L.
Designed by:	Checked by:	Date:
F.J.	F.C.	August 2008
Drawing number:	Rev.	
B2 - Map 5	A	

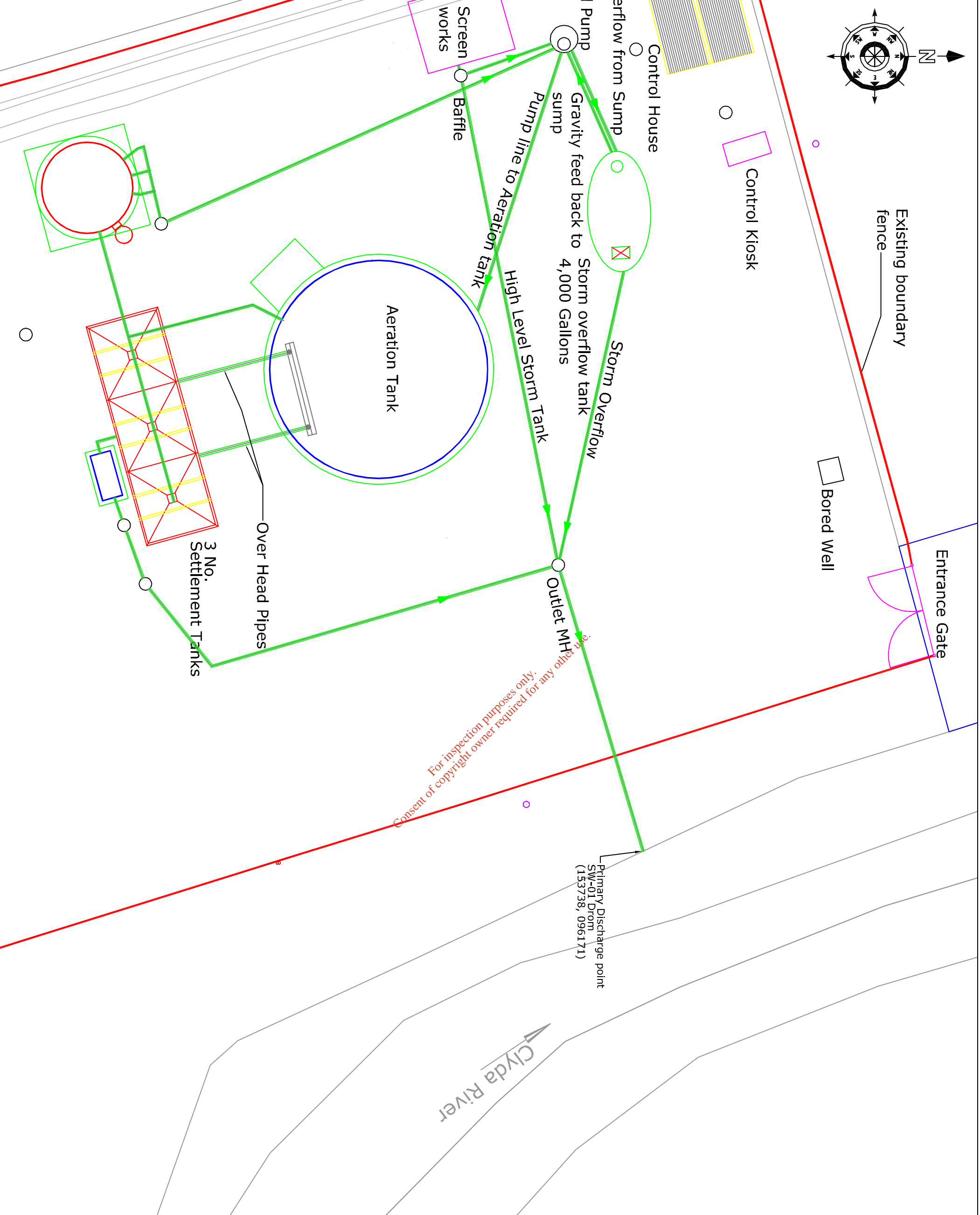
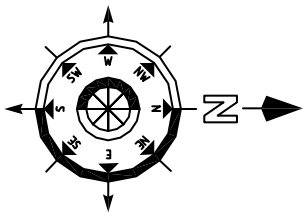

**NOTES**

1. Dimensions are not to be scaled from drawing. For any discrepancies found consult with the design office.
2. This drawing is to be read in conjunction with the Specification.
3. This drawing is to be read in conjunction with all other contract drawings.

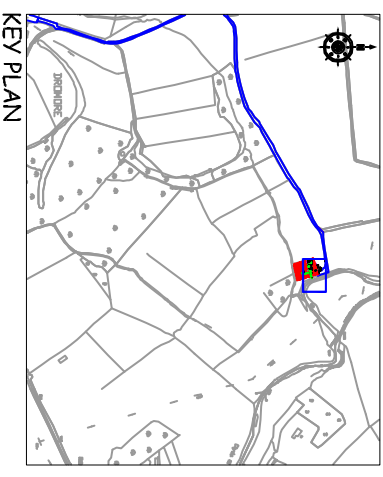

<p><b>Cork County Council,</b> Northern Division.</p>	
<p>N. O'KEEFE, B.E., A/COUNTY ENGINEER, COUNTY HALL, CDRJK.</p>	
<p><b>Job Title:</b> Dromchane &amp; Environs Wastewater Discharge Licence Application</p>	
<p><b>Drawing Title:</b> Location of Primary Discharge Point SW01 - Drom Attachment B3 - Map 6</p>	
<p><b>Scales:</b> 1:500 @ A3</p>	<p><b>Drawn by:</b> D.L.</p>
<p><b>Designed by:</b> F.J.</p>	<p><b>Checked by:</b> F.C.</p>
<p><b>Drawing number:</b> B3 - Map 6</p>	<p><b>Date:</b> August 2008</p>
	<p><b>Rev:</b> A</p>

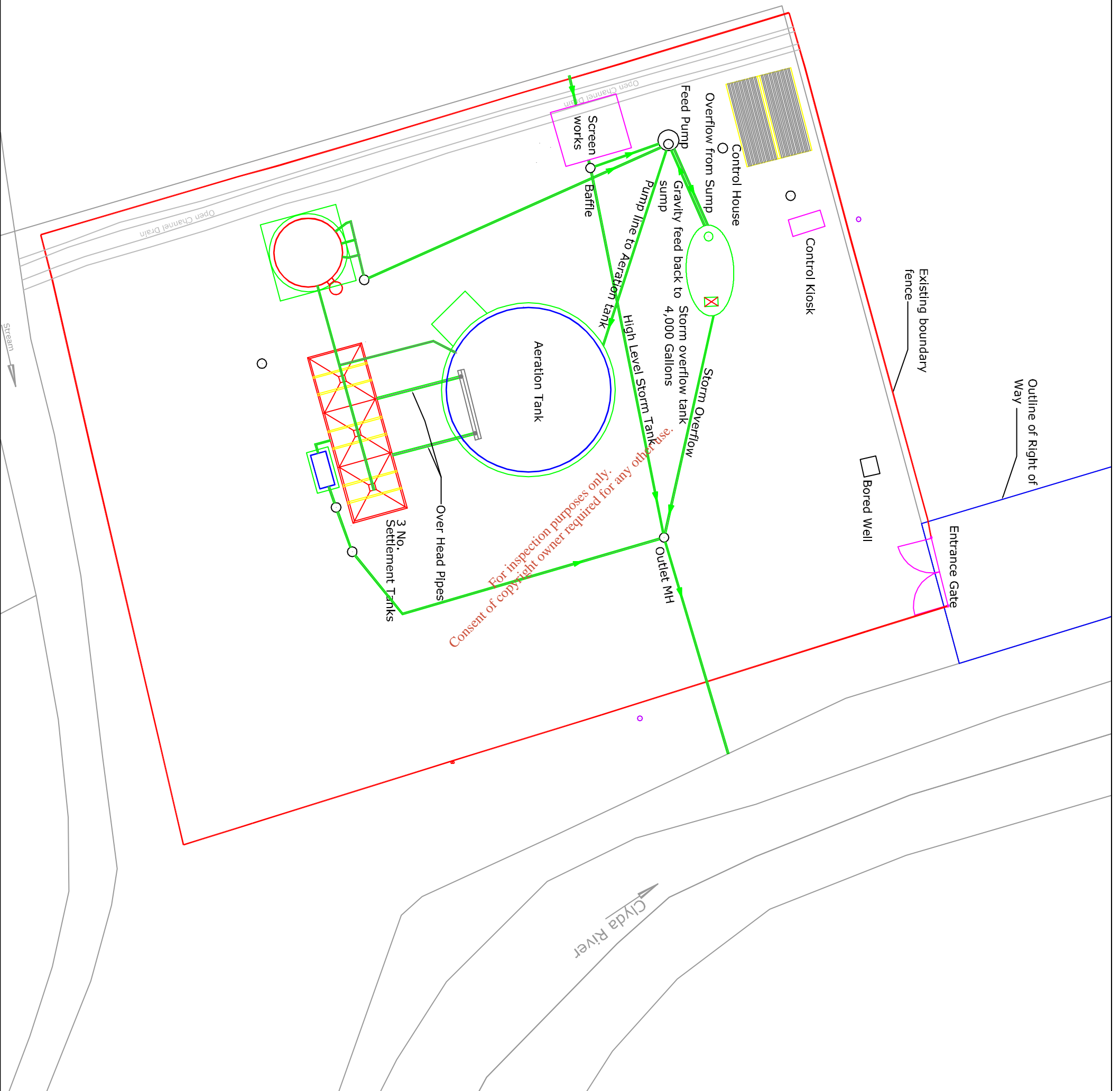
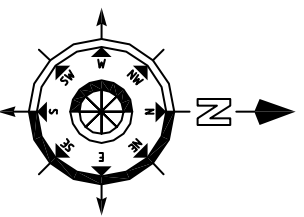

**NOTES**

1. Dimensions are not to be scaled from drawing. For any discrepancies found consult with the design office.
2. This drawing is to be read in conjunction with the Specification.
3. This drawing is to be read in conjunction with all other contract drawings.

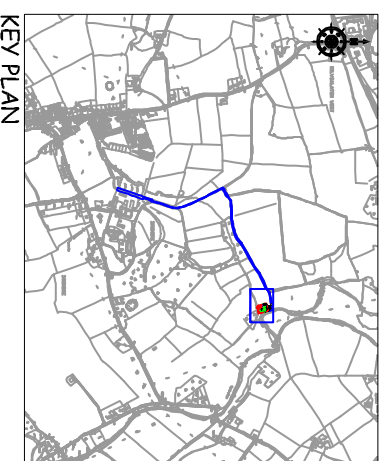

No.	Date	Drawn/Checked	Revision Description
A	04/13	DL	DL
		PB	Revised wastewater treatment plant layout

Cork County Council,  
Northern Division.



N. O'KEEFE, B.E.,  
A/COUNTY ENGINEER,  
COUNTY HALL,  
CDRJK.

**Job Title:**  
Dromahane & Environs  
Wastewater Discharge  
Licence Application

**Drawing Title:**  
Location of Waste Water  
Treatment Plant  
Attachment C1 - Map 9

Scales:		Drawn by:	
1:250 @ A3	DL	DL	DL
Designed by:		Date:	
F.J.	F.C.	August 2008	
Drawing number:		Rev.	
C1 - Map 9		A	

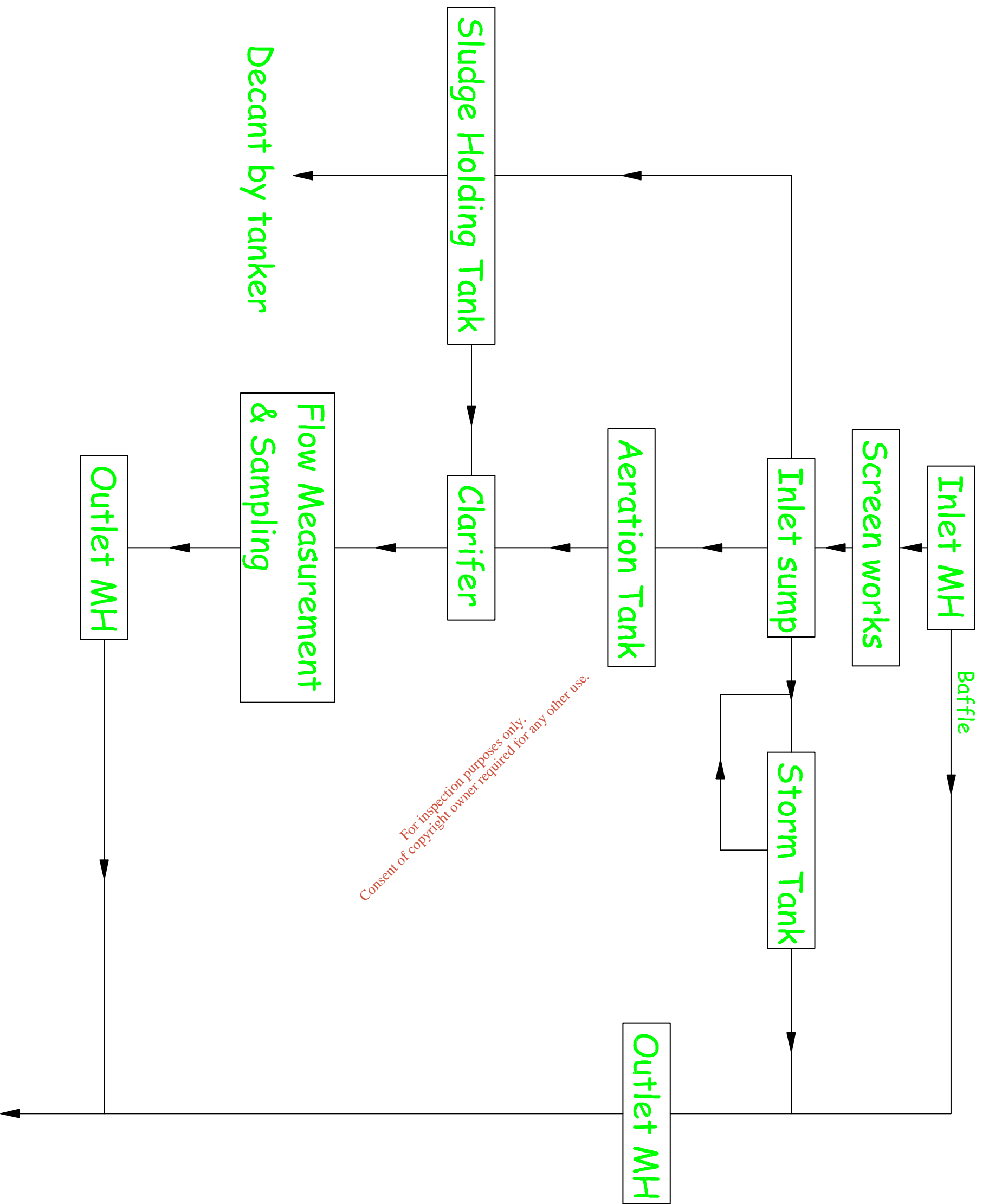

For inspection purposes only.  
Consent of copyright owner required for any other use.

**NOTES**

1. Dimensions are not to be scaled from drawing. For any discrepancies found consult with the design office.
2. This drawing is to be read in conjunction with the Specification.
3. This drawing is to be read in conjunction with all other contract drawings.

<p><b>Cork County Council,</b> Northern Division.</p> <p><b>N. D'KEEFFE, B.E.,</b> A/COUNTY ENGINEER, COUNTY HALL, CDRJK.</p> <p><b>Job Title:</b> Dromahane &amp; Environs Wastewater Discharge Licence Application</p> <p><b>Drawing Title:</b> Schematic showing Existing Treatment Plant Process Attachment C1 - Drawing 1</p>	<table border="1" style="width: 100%; border-collapse: collapse;"> <thead> <tr> <th>No.</th> <th>Date</th> <th>Drawn</th> <th>Surv/Chkd</th> <th>DL</th> <th>PB</th> <th>Revised existing treatment process</th> </tr> </thead> <tbody> <tr> <td>A</td> <td>04/13</td> <td>DL</td> <td>DL</td> <td></td> <td></td> <td></td> </tr> </tbody> </table> <p><b>Scales:</b> 1:5000 @ A3</p> <table border="1" style="width: 100%; border-collapse: collapse;"> <tr> <td>Designed by: F.J.</td> <td>Checked by: F.C.</td> <td>Drawn by: D.L.</td> <td>Date: August 2008</td> </tr> </table> <p><b>Drawing number:</b> C1 - Drawing 1</p>	No.	Date	Drawn	Surv/Chkd	DL	PB	Revised existing treatment process	A	04/13	DL	DL				Designed by: F.J.	Checked by: F.C.	Drawn by: D.L.	Date: August 2008
No.	Date	Drawn	Surv/Chkd	DL	PB	Revised existing treatment process													
A	04/13	DL	DL																
Designed by: F.J.	Checked by: F.C.	Drawn by: D.L.	Date: August 2008																

## APPENDIX C

## Revised Non-Technical Summary

*For inspection purposes only.  
Consent of copyright owner required for any other use.*

## **SECTION A: NON-TECHNICAL SUMMARY**

Dromahane is a village located 5km southeast of Mallow town. The village has developed around a crossroads and has experienced substantial construction and population growth in recent years.

### **The Waste Water Works and the Activities Carried Out Therein**

The wastewater in Dromahane is collected in a partially combined foul and separate foul sewerage drainage network. The wastewater from both the village gravitates to the wastewater treatment plant.

Dromahane WWTP is designed for a Population Equivalent (PE) of 1,000, which was commissioned in 1998. Activated Sludge is the process employed at the Dromahane waste water treatment plant. Influent initially gravitates into a circular GPR inlet sump, from where the effluent is pumped to a steel circular aeration tank. The effluent then flows into the hopper bottomed settling tank. The solids settle while the supernatant flows over the weir and discharges to the river. Sludge may be returned from the settling tank to the aeration tank and excess sludge is removed from the settling tank as required and removed off site for disposal.

In the event of high storm flows effluent may bypass the plant via the baffle plate at the inlet manhole. During normal storm periods, effluent overflows at the sump to the storm holding tank, which gravitates back to the sump after the sump level reduces. In the event of the storm tank fill the screened effluent discharges via the outlet pipe.

Based on average hydraulic load in 2012 of 280m<sup>3</sup>/225l/head/day, the hydraulic p.e equates to 1,244.

Dromahane WWTP is operated by Cork County Council. The plant is operated by a caretaker who duties also involves the maintenance of a number of other small WWTP's in the area.

### **The sources of emissions from the waste water works**

The pollution load for the Dromahane agglomeration arises from the following areas:

- Domestic population
- Commercial premises
- School & crèches
- Infiltration

The sewerage from all commercial premises is collected via the public sewer and treated in conjunction with the domestic waste at the WWTP.

### **The nature and quantities of foreseeable emissions from the waste water works into the receiving aqueous environment as well as identification of significant effects of the emissions on the environment**

The final effluent is discharged to the Clyda River, which is adjacent to the wastewater treatment plant site.

The normal daily average effluent discharge was measured as 280m<sup>3</sup>/day in 2012. In times of rainfall discharges would be greater than this depending on the intensity and duration of the rainfall event, in 2012 the maximum daily volume was 934m<sup>3</sup> recorded on 24th December 2012.

## **The proposed technology and other techniques for preventing or, where this is not possible, reducing emissions from the waste water works**

### **Technology**

The WWTP has a sufficient number of standby pumps, automatic sample facilities, etc is provided to ensure continuation of the wastewater treatment.

The treatment works consists of the following elements:

- Inlet Works
- Forward Feed Sump
- Aeration Tank
- Settling Tank
- Storm Tank
- Sludge Holding Tank
- Outfall to Clyda River

### **Further measures planned to comply with the general principle of the basic obligations of the operator, i.e., that no significant pollution is caused**

An automatic screen was installed in 2009, which caters for 6DWF through the plant. A manual bypass was incorporated into the installation of the screen.

A bored well was drilled to provide a reliable supply of water to the wastewater treatment plant.

The provision of an automatic screen and water supply to the plant should ensure that the basic obligations of the operator are being adhered to.

### **Measures planned to monitor emissions into the environment**

The Cork County Council Environmental Laboratory carries out sampling of the influent and effluent biannually. Sampling, Monitoring and analysis of the wastewater sludge is also undertaken by the Environmental Laboratory.

The Cork County Council Environmental Department located in Inniscarra takes samples from the River Bride upstream and downstream of the wastewater treatment plant approximately 6 times per year. Samples of the influent and effluent are also taken at these times.

The new wastewater treatment plant shall be equipped with automatic samplers on the inlet, overflow and outlet lines.

The EU Water Framework Directive Monitoring Programme is to be fully operational by the year 2012. This monitoring programme was prepared by the EPA to meet the requirements of the EU Water Framework Directive (2000/60/EC) and National Regulations implementing the Water Framework Directive (S.I. No. 722 of 2003) and National Regulations implementing the Nitrates Directive (S.I. No. 788 of 2005).