

Consent of copyright owner required for any other use.

ARUP

MANAHAN PLANNERS
Chartered Town Planning Consultants

patel tonra ltd
environmental solutions

M.E.H.L. HOLLYWOOD
Murphy Environmental Hollywood Ltd

MEHL Integrated Waste Management Facility
Hollywood Great, Nags Head, Naul, Co Dublin

2010 Existing Traffic Flows

December 2010 **Figure 8.2**

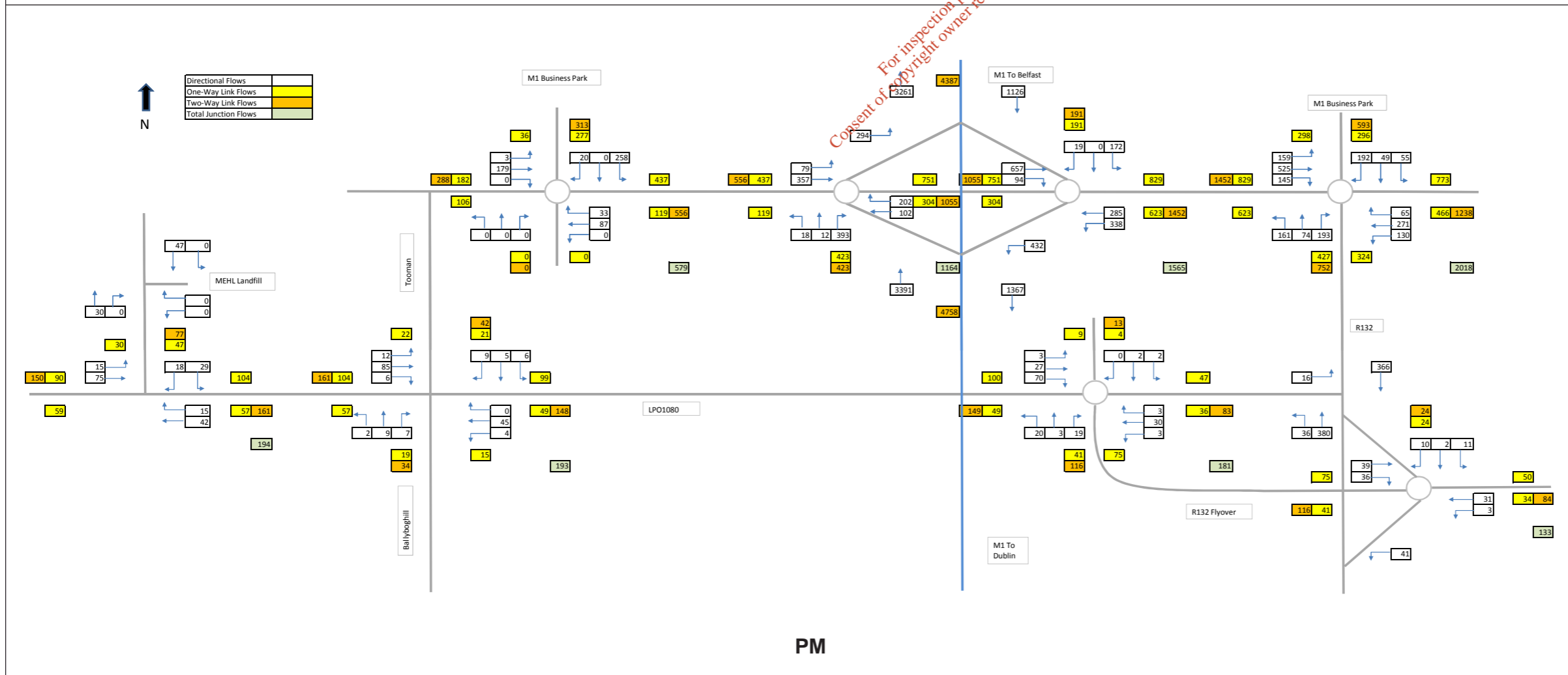
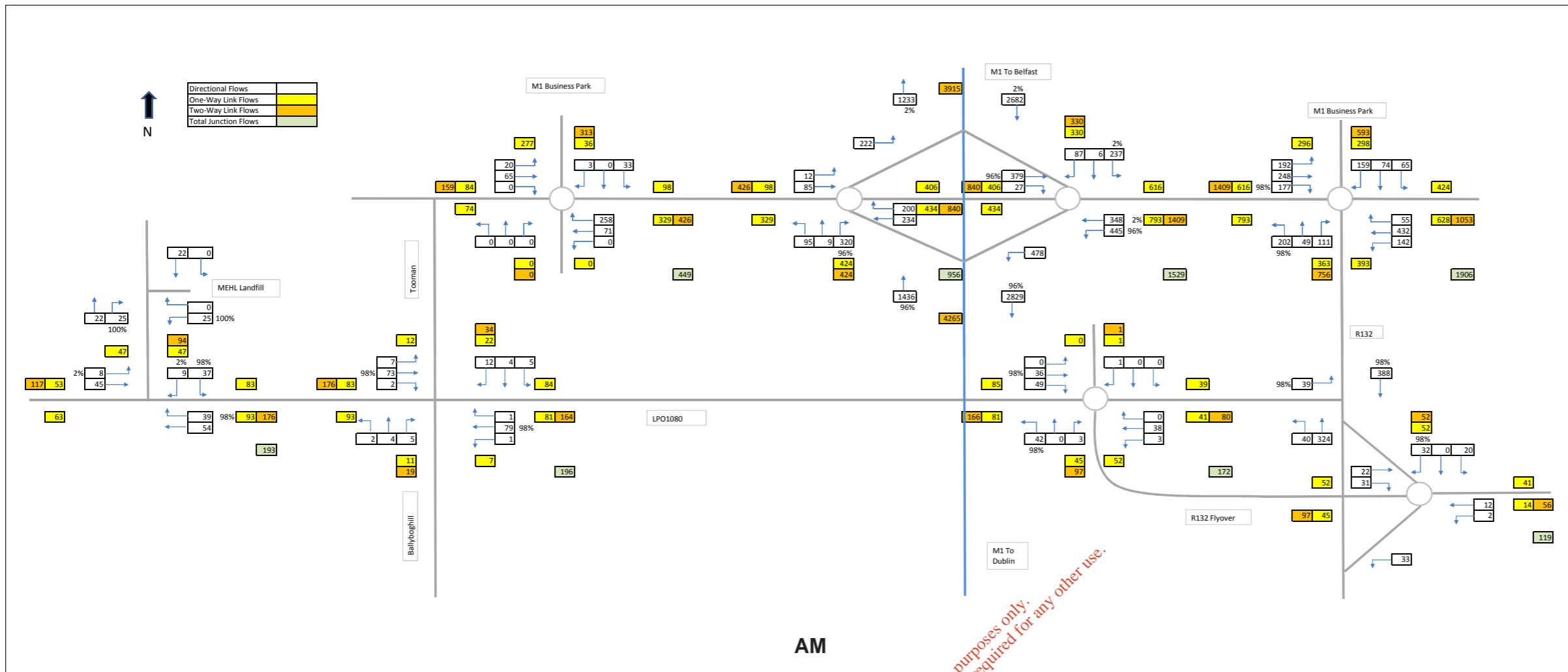

ARUP



patel tonra ltd
environmental solutions

MANAHAN
PLANNERS
Chartered
Town Planning
Consultants



Murphy Environmental
Hollywood Ltd
MEHL Integrated
Waste Management Facility
Hollywood Great, Nags Head, Naul, Co Dublin

2011 Do Nothing Traffic Flows

December 2010

Figure 8.3

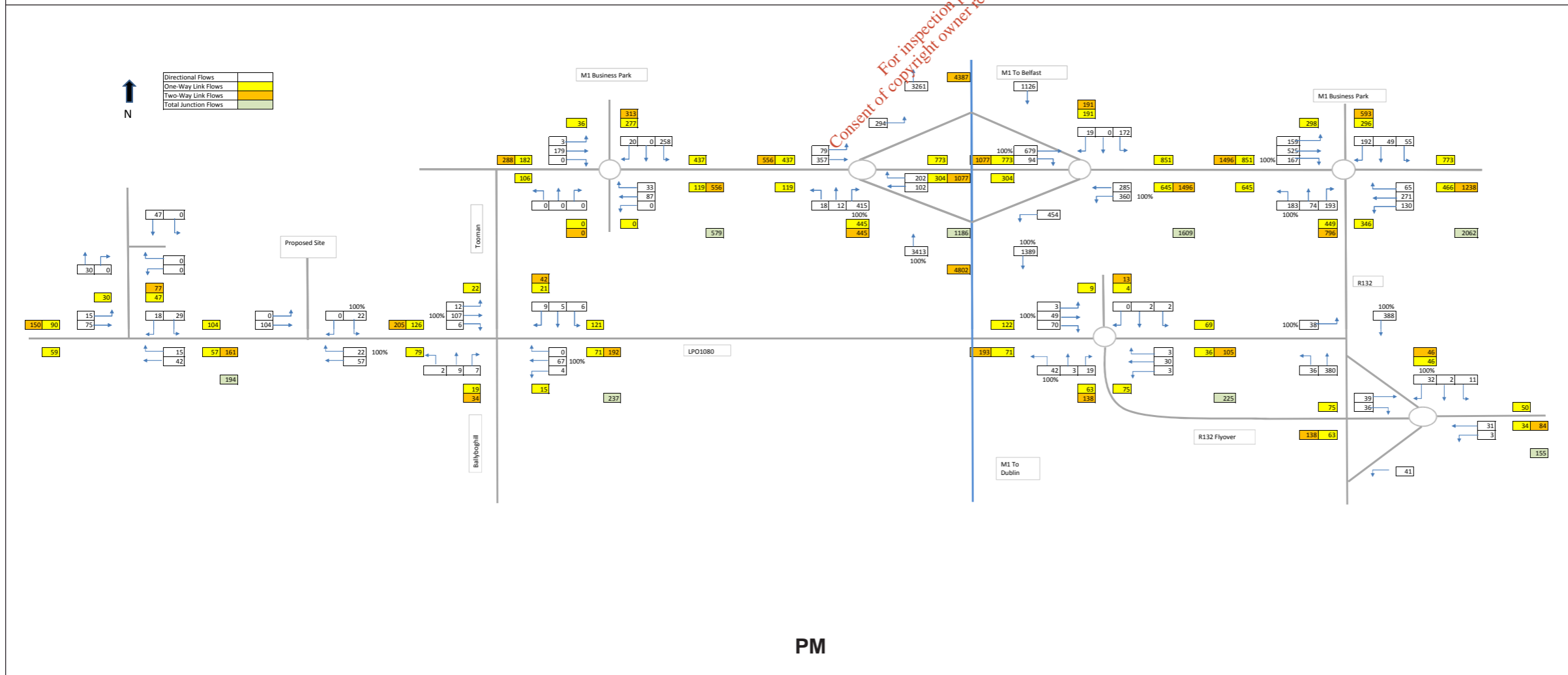
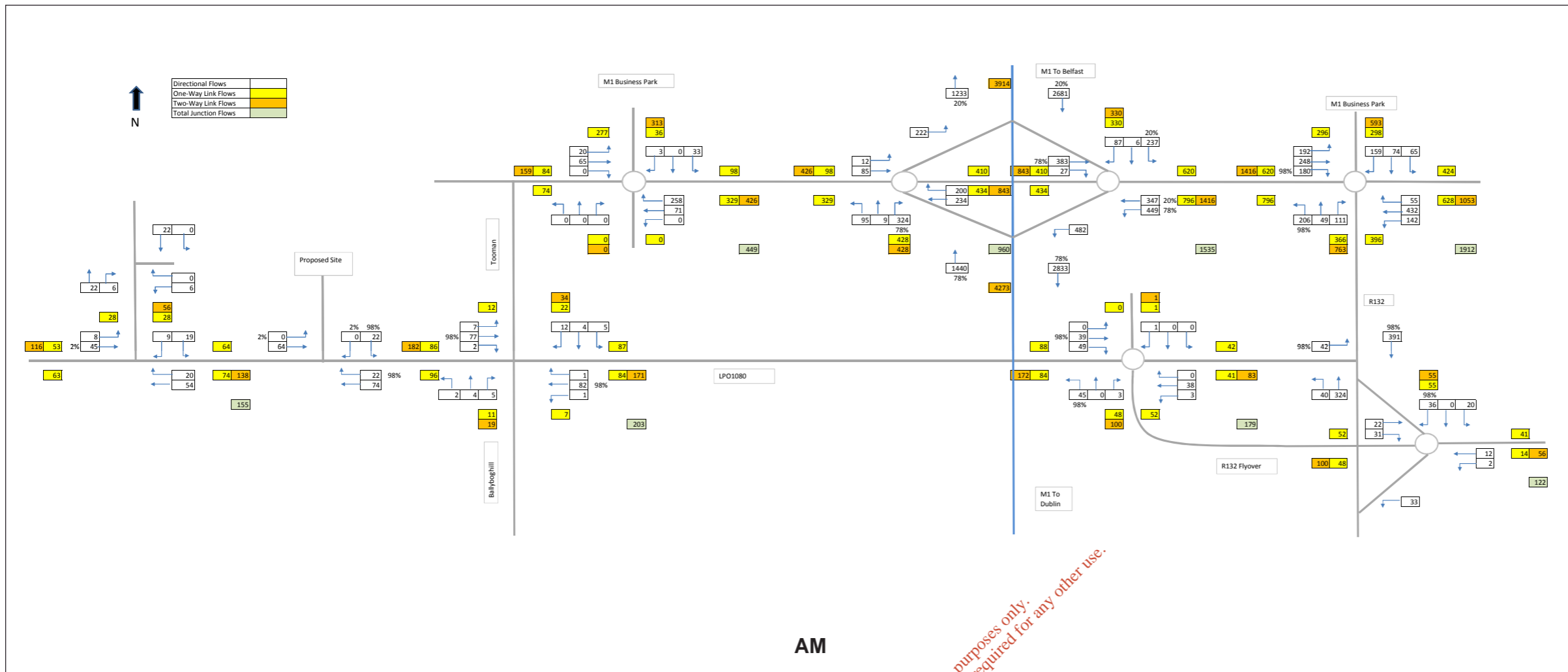

For inspection purposes only.
Consent of copyright owner required for any other use.

ARUP



patel tonra ltd
environmental solutions

MANAHAN PLANNERS
Chartered Town Planning Consultants



MEHL Integrated Waste Management Facility
Hollywood Great, Nags Head, Naul, Co Dublin

2011 Do Something Traffic Flows

December 2010

Figure 8.4

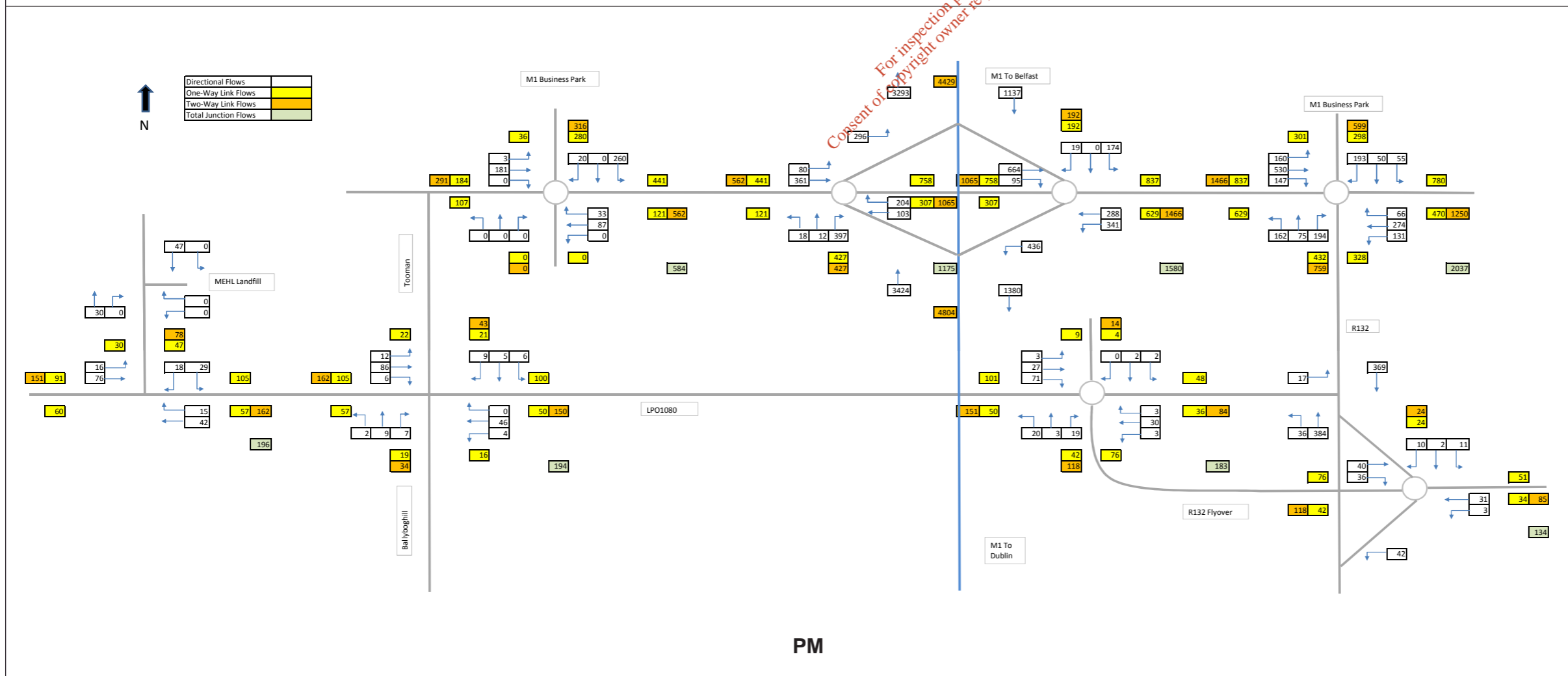
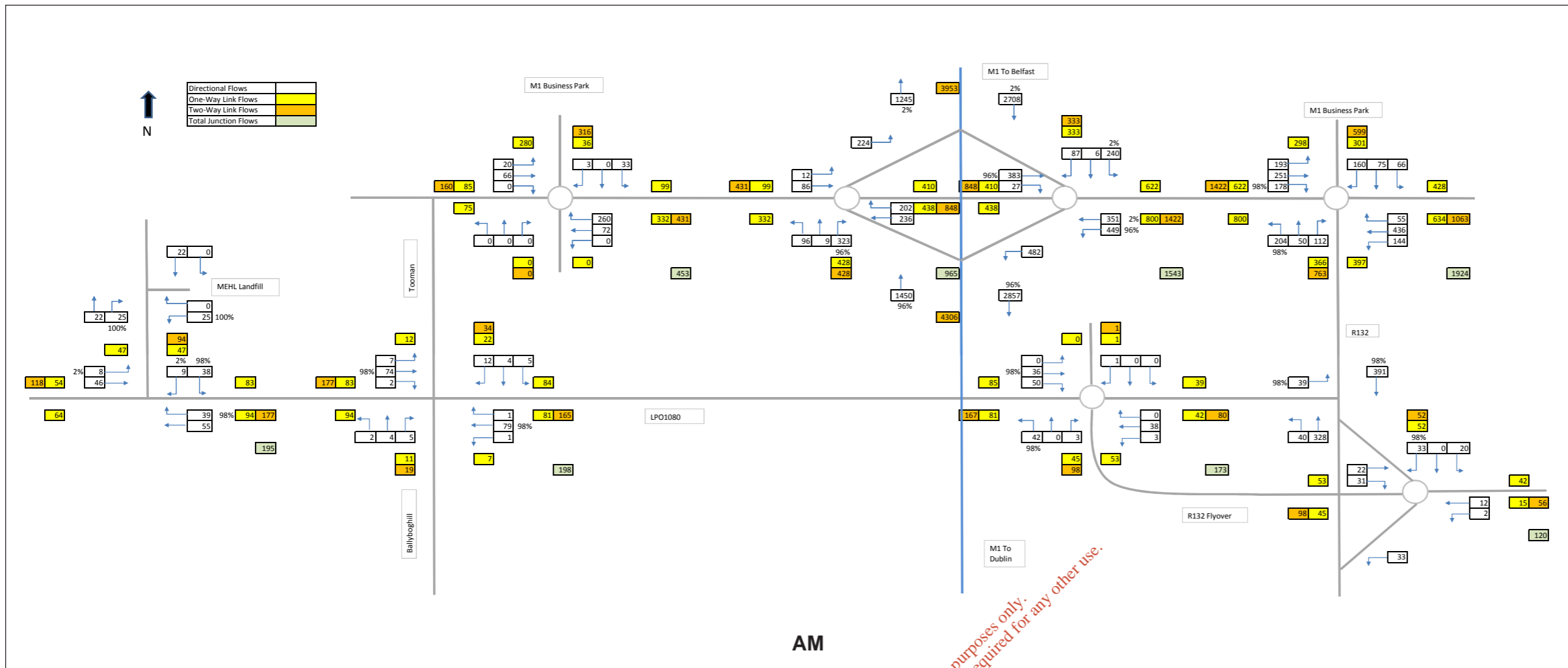

Consent of copyright owner required for any other use.

ARUP

wyg.

MANAHAN PLANNERS
 Chartered Town Planning Consultants

patel tonra ltd
 environmental solutions

M.E.H.L. HOLLYWOOD
Murphy Environmental Hollywood Ltd

MEHL Integrated Waste Management Facility
 Hollywood Great, Nags Head, Naul, Co Dublin

2014 Do Nothing, Without Fingal, Traffic Flows

December 2010 Figure 8.5

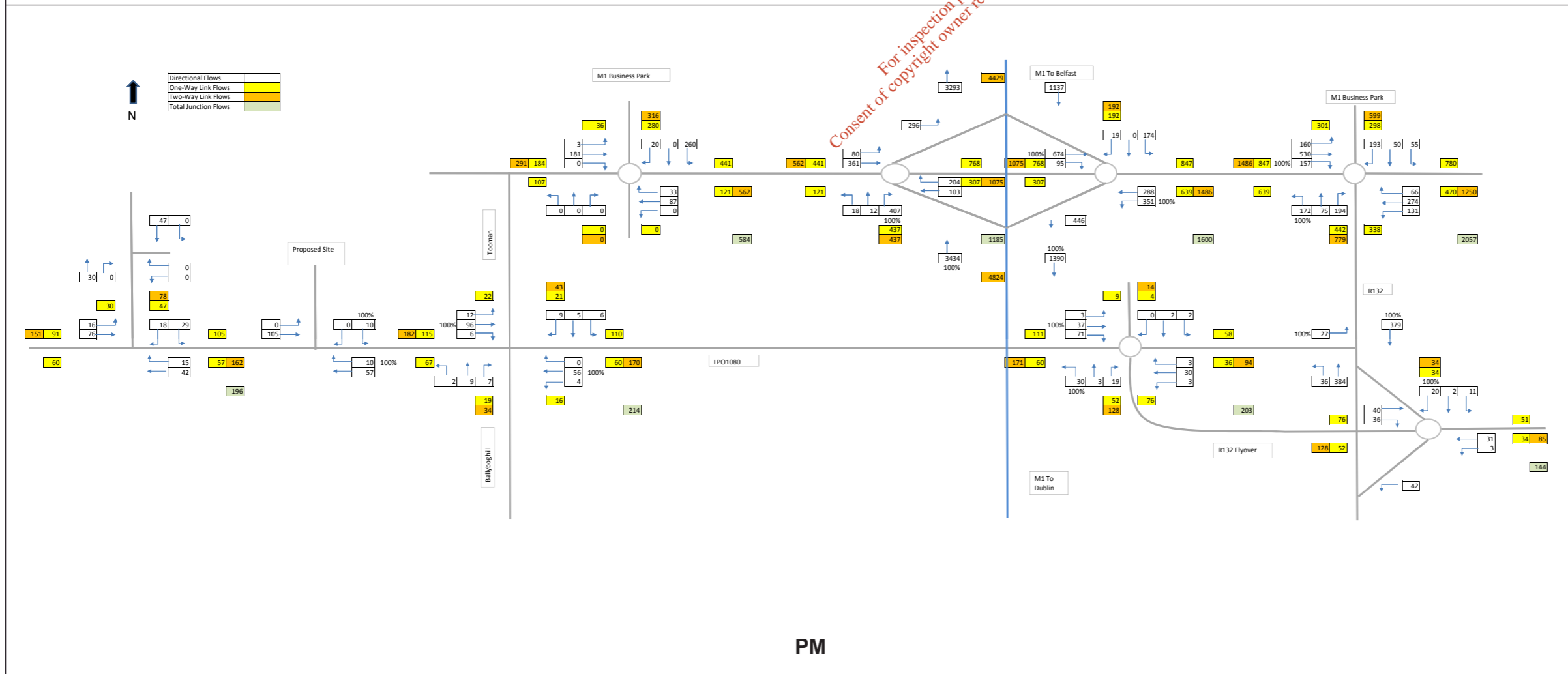
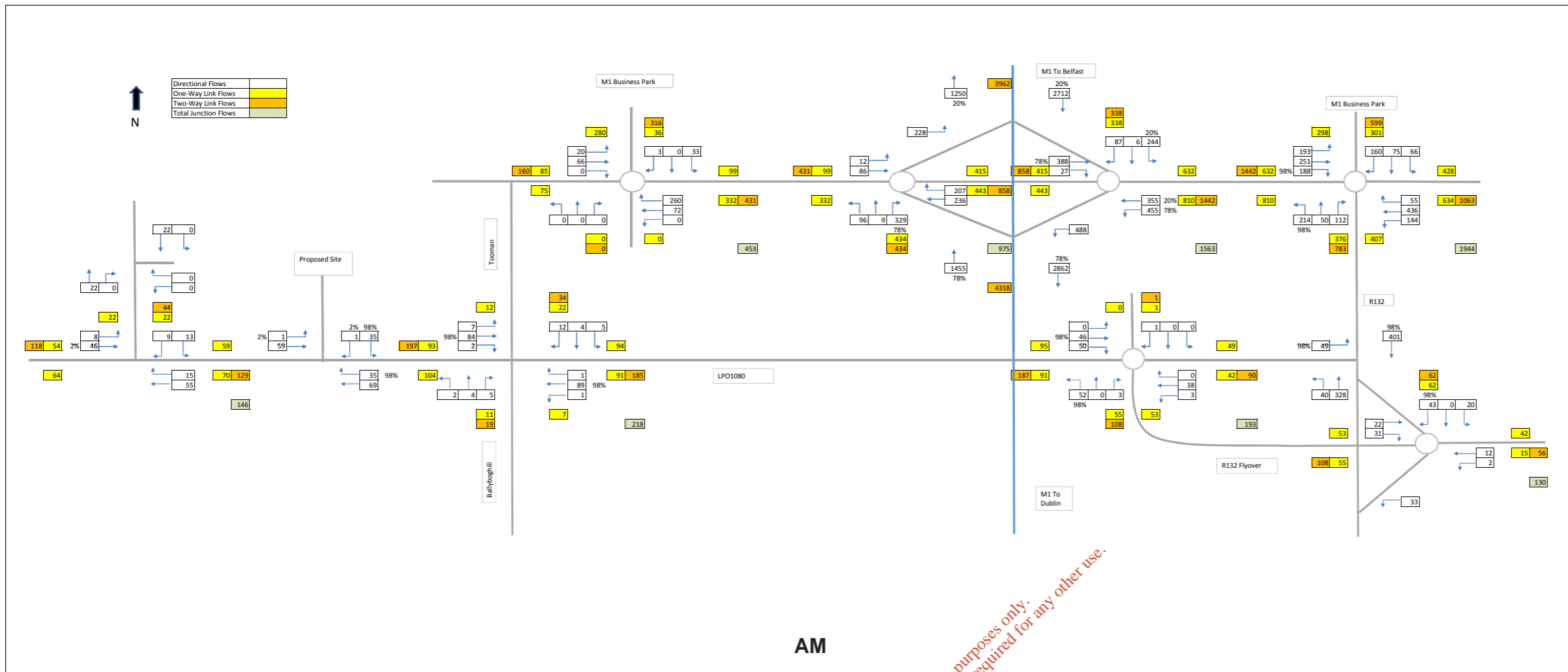

For inspection purposes only.
Consent of copyright owner required for any other use.

ARUP



MEHL Integrated Waste Management Facility
Hollywood Great, Nags Head, Naul, Co Dublin

2014 Do Something, Without Fingal, Traffic Flows

December 2010

Figure 8.6

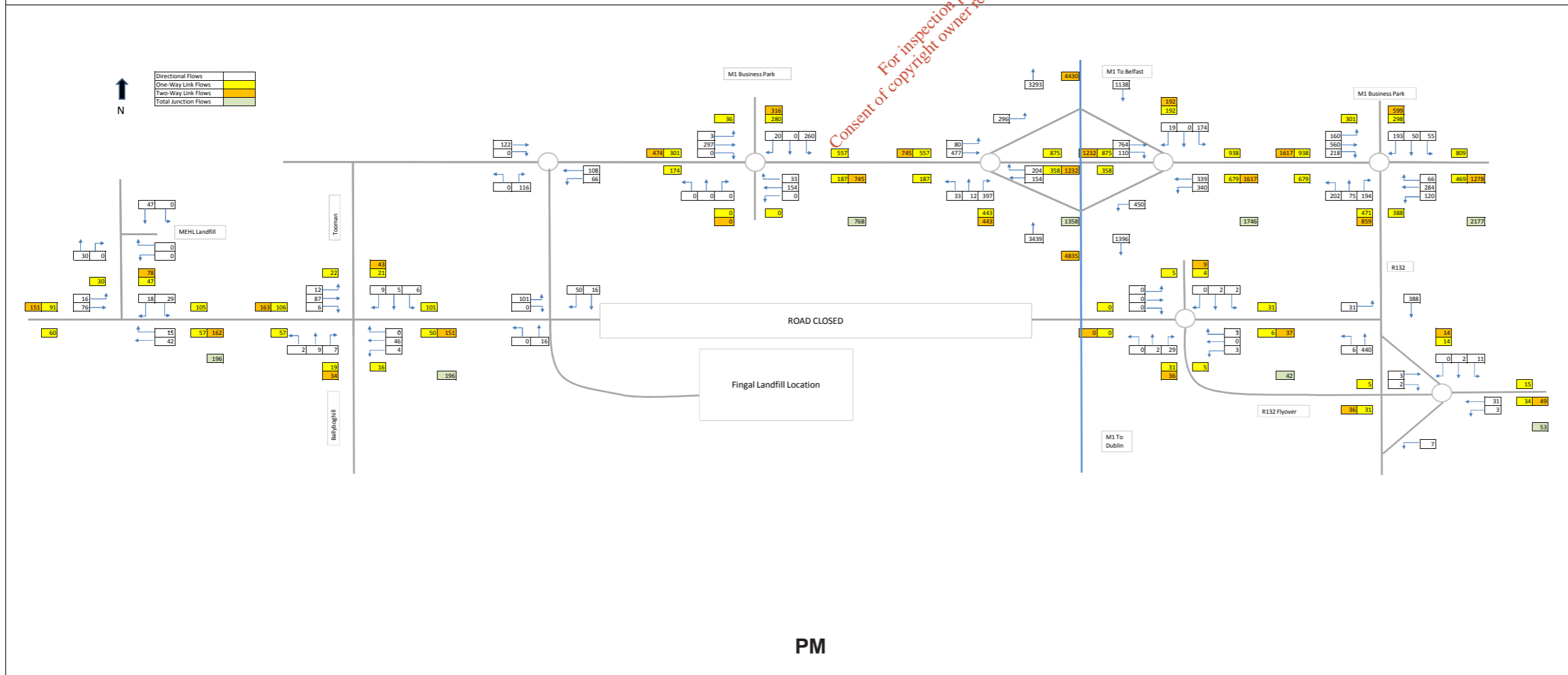
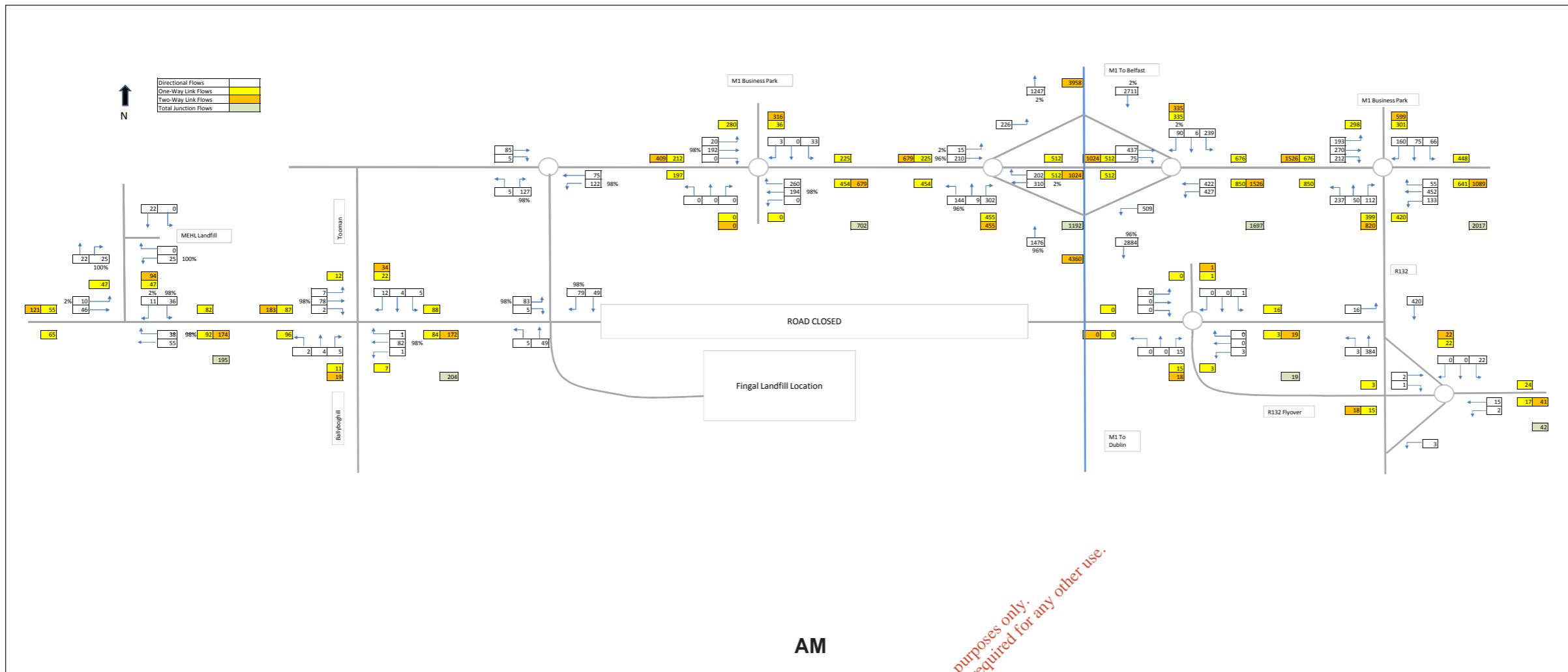

For inspection purposes only.
Consent of copyright owner required for any other use.

ARUP



patel tonra ltd
environmental solutions

MANAHAN PLANNERS
Chartered Town Planning Consultants



Murphy Environmental Hollywood Ltd
MEHL Integrated Waste Management Facility
Hollywood Great, Nags Head, Naul, Co Dublin

2014 Do Nothing, With Fingal, Traffic Flows

December 2010

Figure 8.7

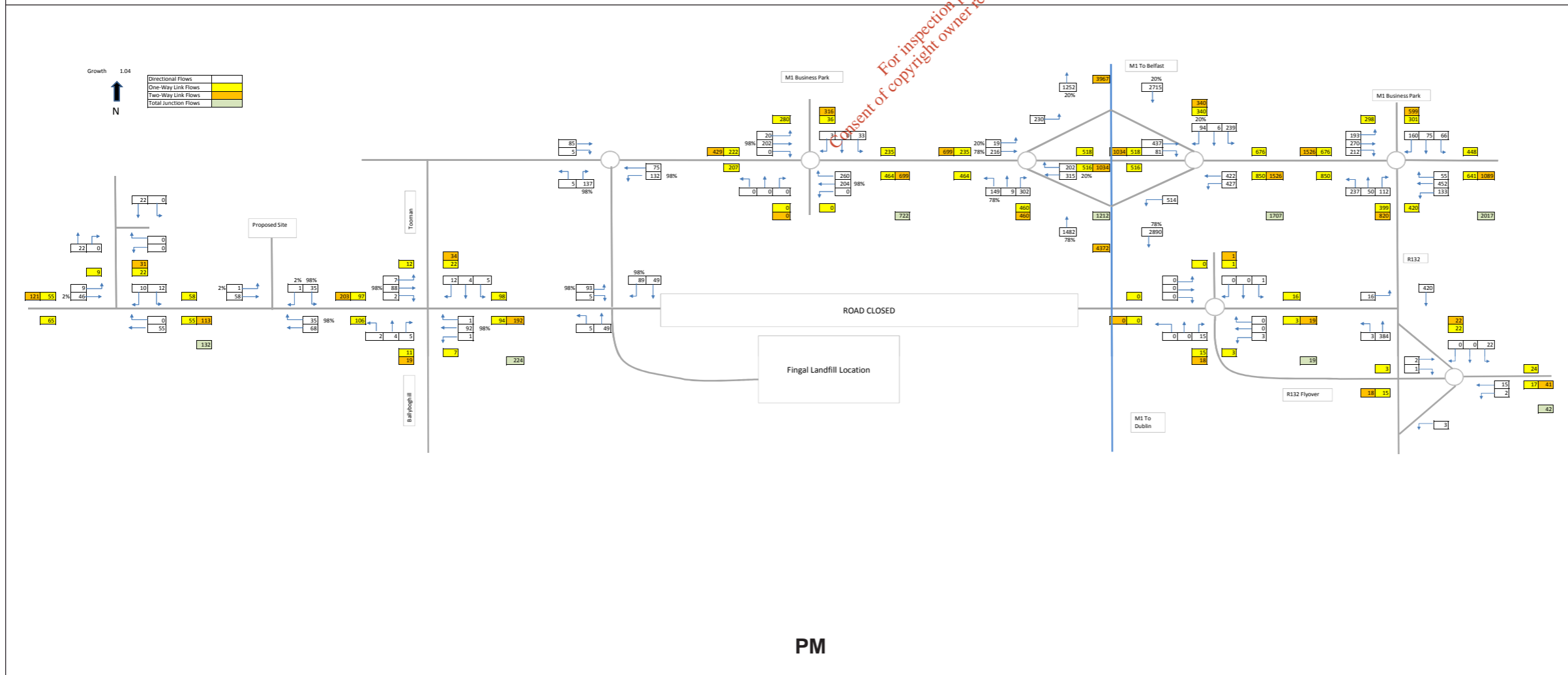
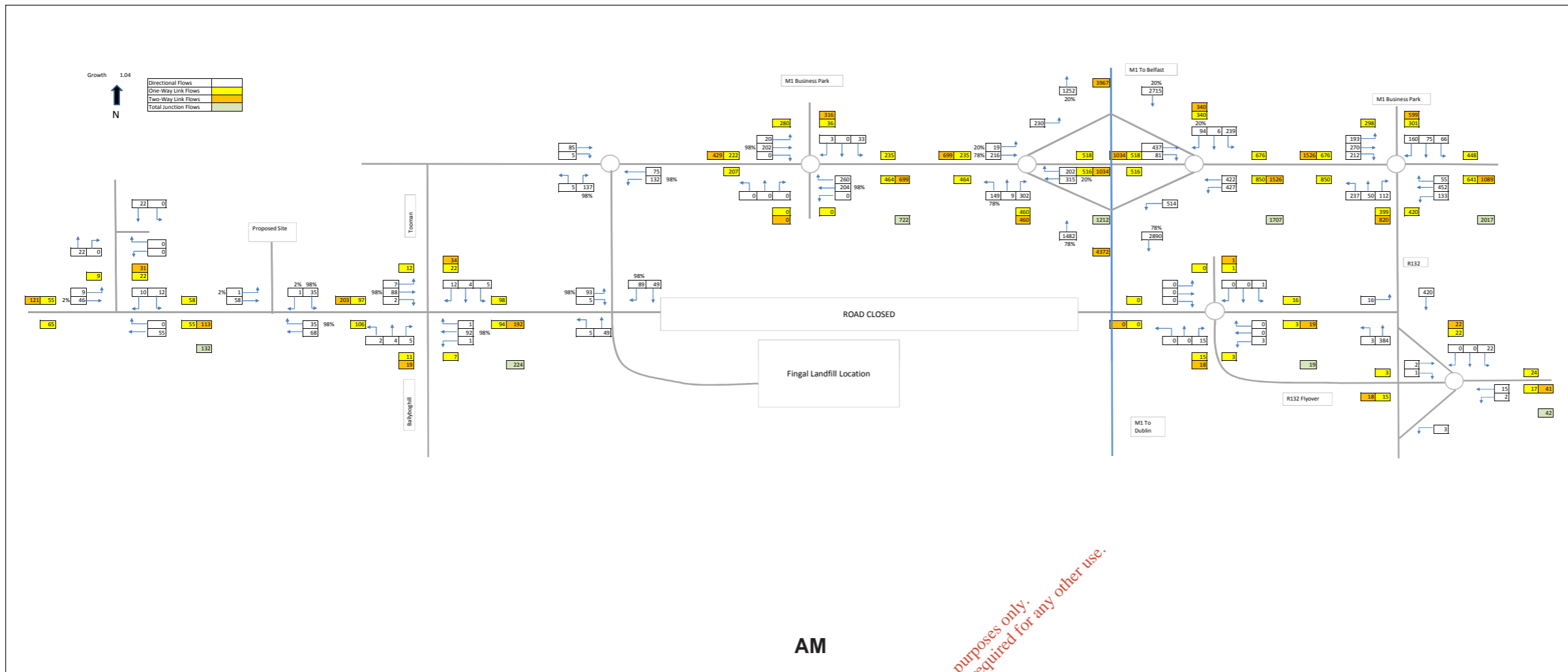

ARUP



patel tonra ltd
environmental solutions

MANAHAN
PLANNERS
Chartered
Town Planning
Consultants



MEHL Integrated
Waste Management Facility
Hollywood Great, Nags Head, Naul, Co Dublin

2014 Do Something, With Fingal,
Traffic Flows

December 2010

Figure 8.8

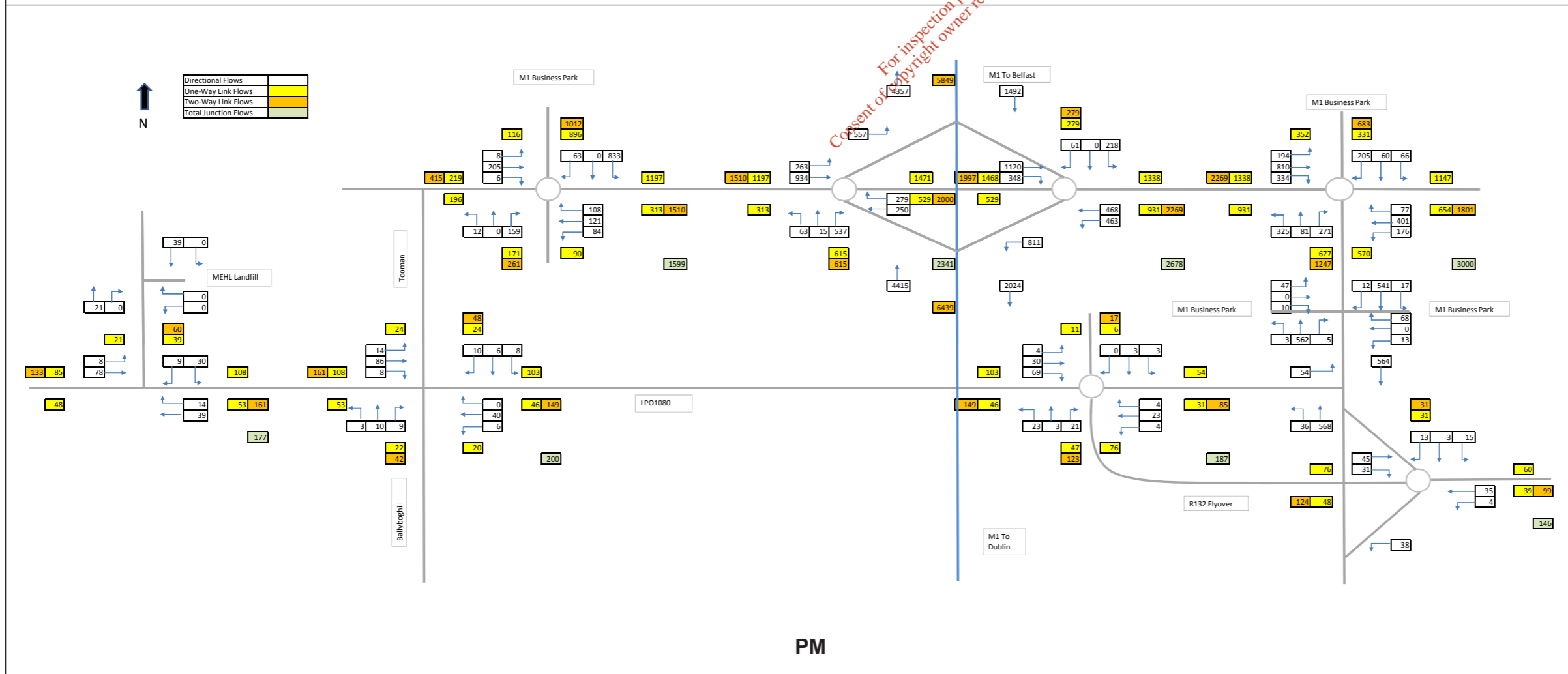
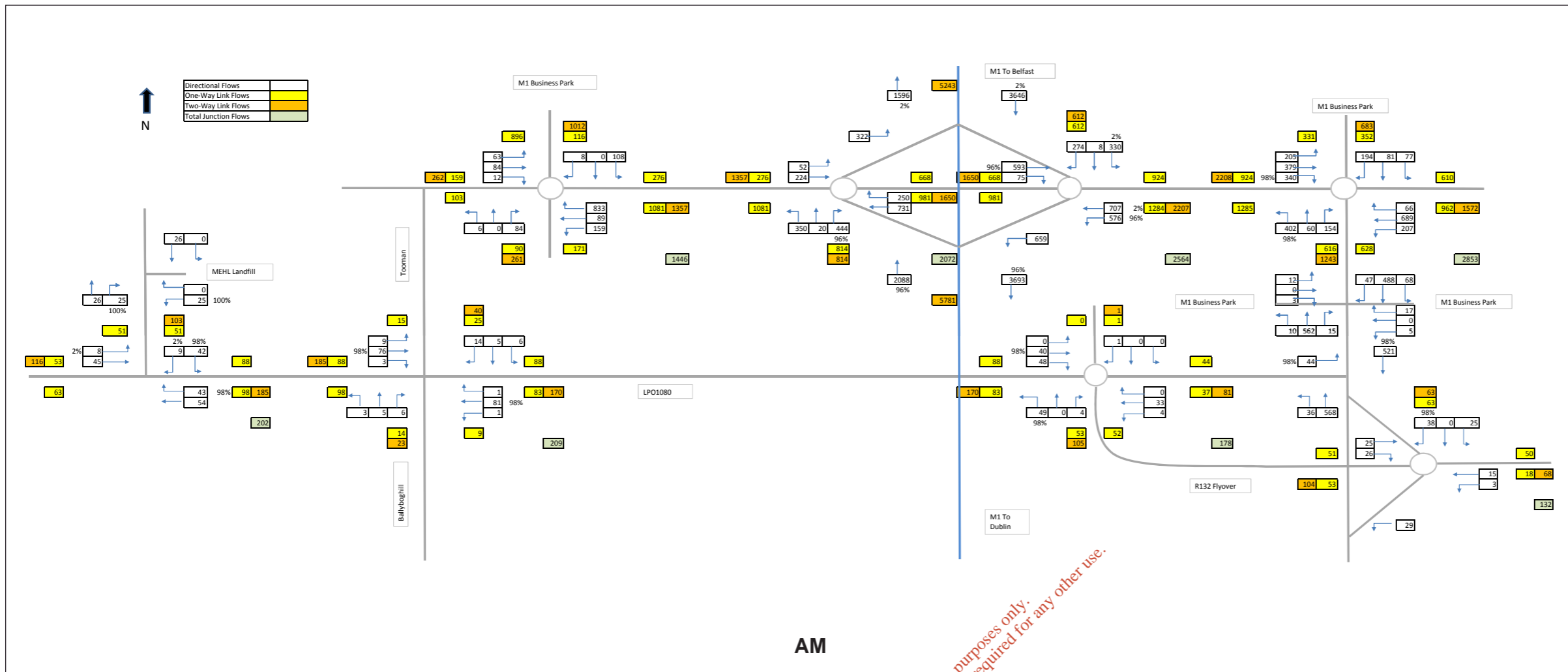

For inspection purposes only.
Consent of copyright owner required for any other use.

ARUP

wyg.

MANAHAN PLANNERS
Chartered Town Planning Consultants

patel tonra ltd
environmental solutions

M.E.H.L. HOLLYWOOD
Murphy Environmental Hollywood Ltd

MEHL Integrated Waste Management Facility
Hollywood Great, Nags Head, Naul, Co Dublin

2024 Do Nothing, Without Fingal, Traffic Flows

December 2010 Figure 8.9

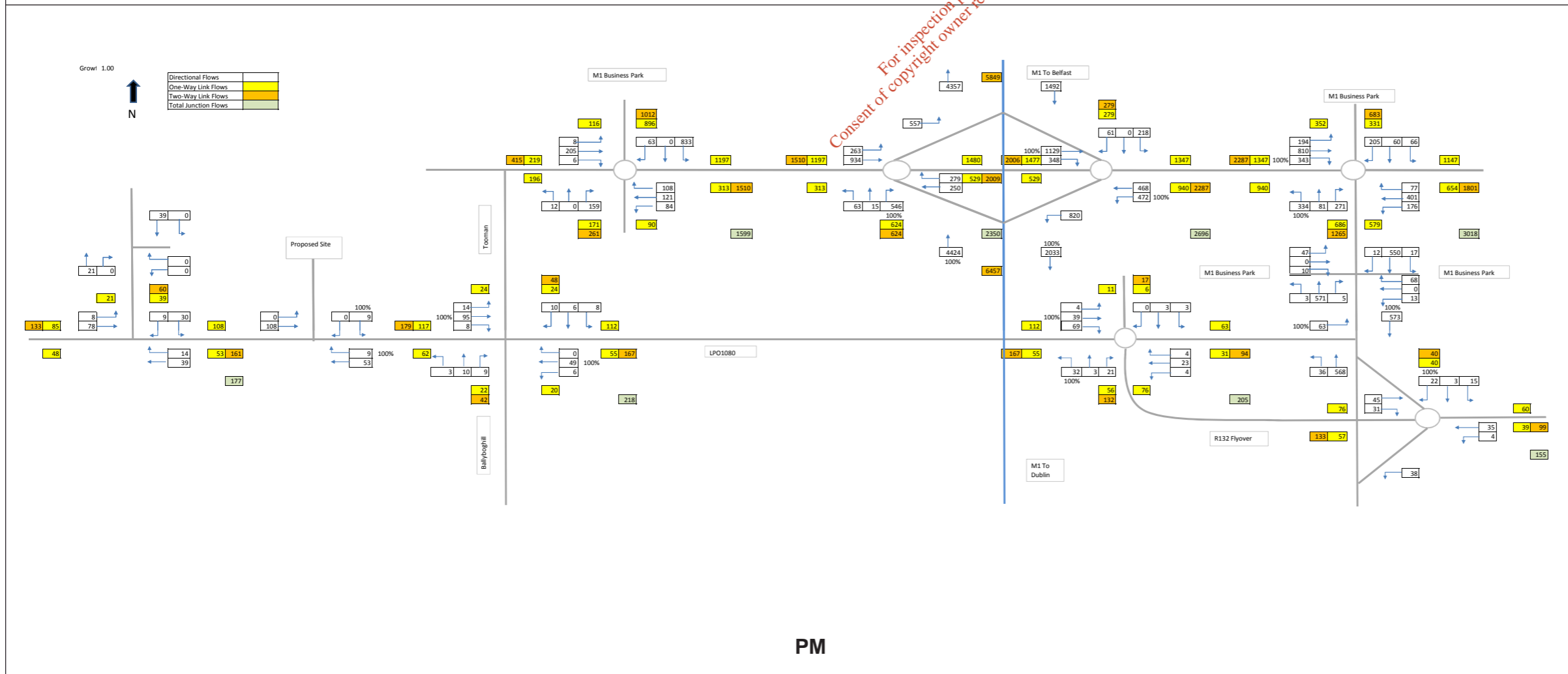
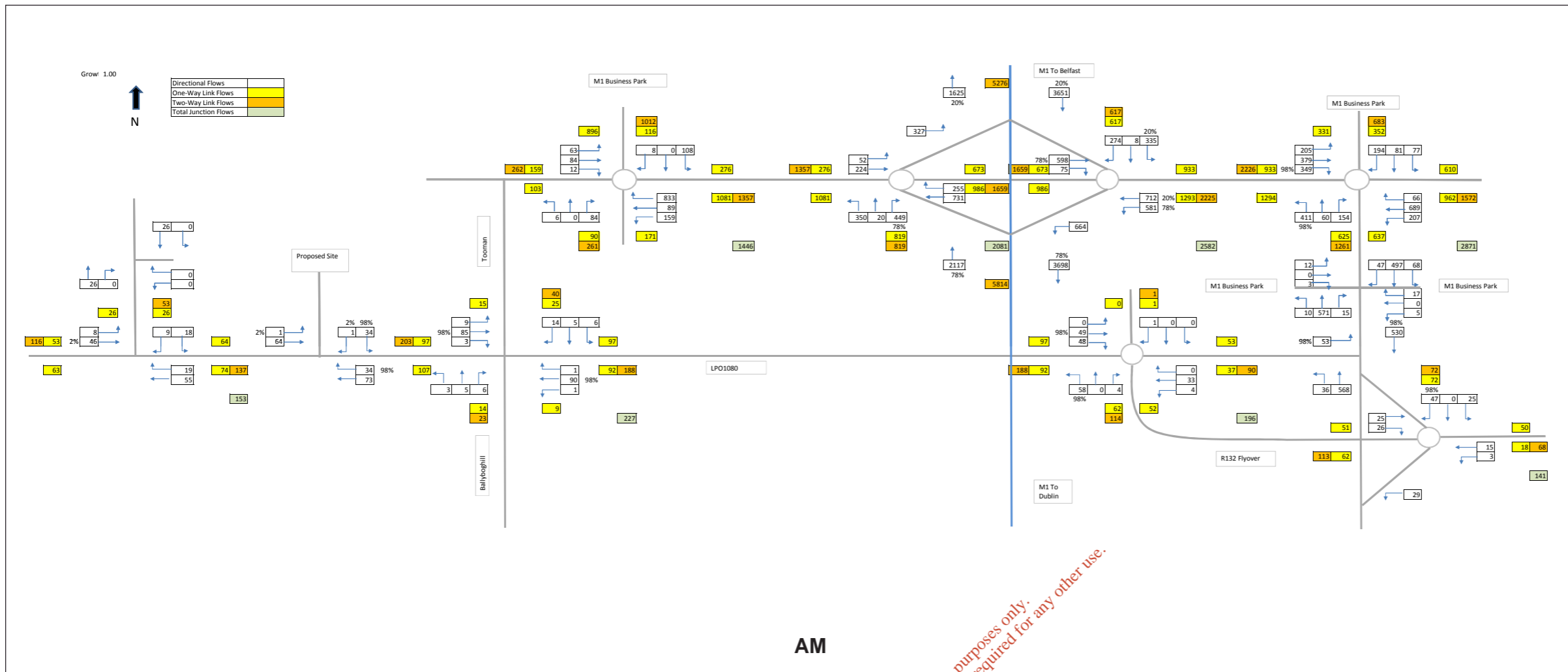

For inspection purposes only.
Consent of copyright owner required for any other use.

ARUP



patel tonra ltd
environmental solutions

MANAHAN PLANNERS
Chartered Town Planning Consultants



MEHL Integrated Waste Management Facility
Hollywood Great, Nags Head, Naul, Co Dublin

2024 Do Something, Without Fingal, Traffic Flows

December 2010

Figure 8.10

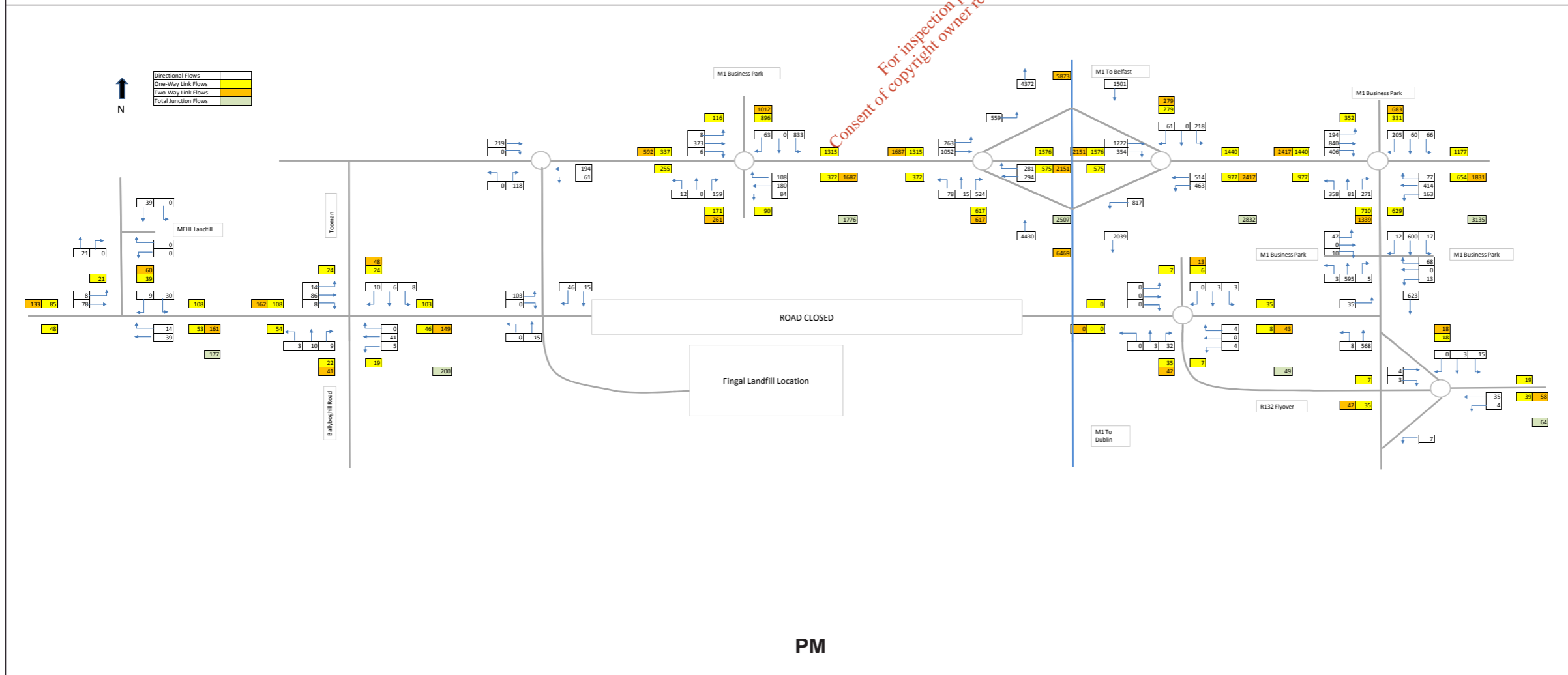
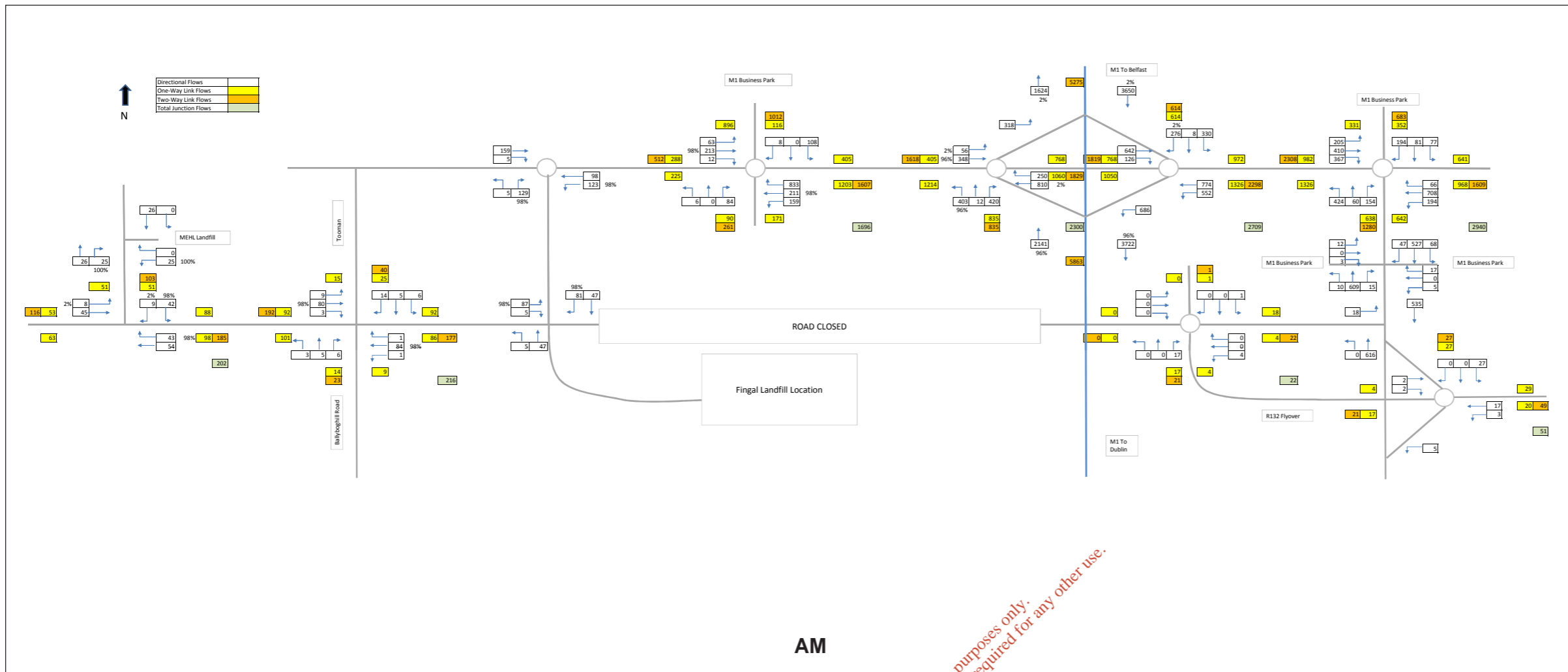

For inspection purposes only.
Consent of copyright owner required for any other use.

ARUP



MEHL Integrated Waste Management Facility
Hollywood Great, Nags Head, Naul, Co Dublin

2024 Do Nothing, With Fingal, Traffic Flows

December 2010

Figure 8.11

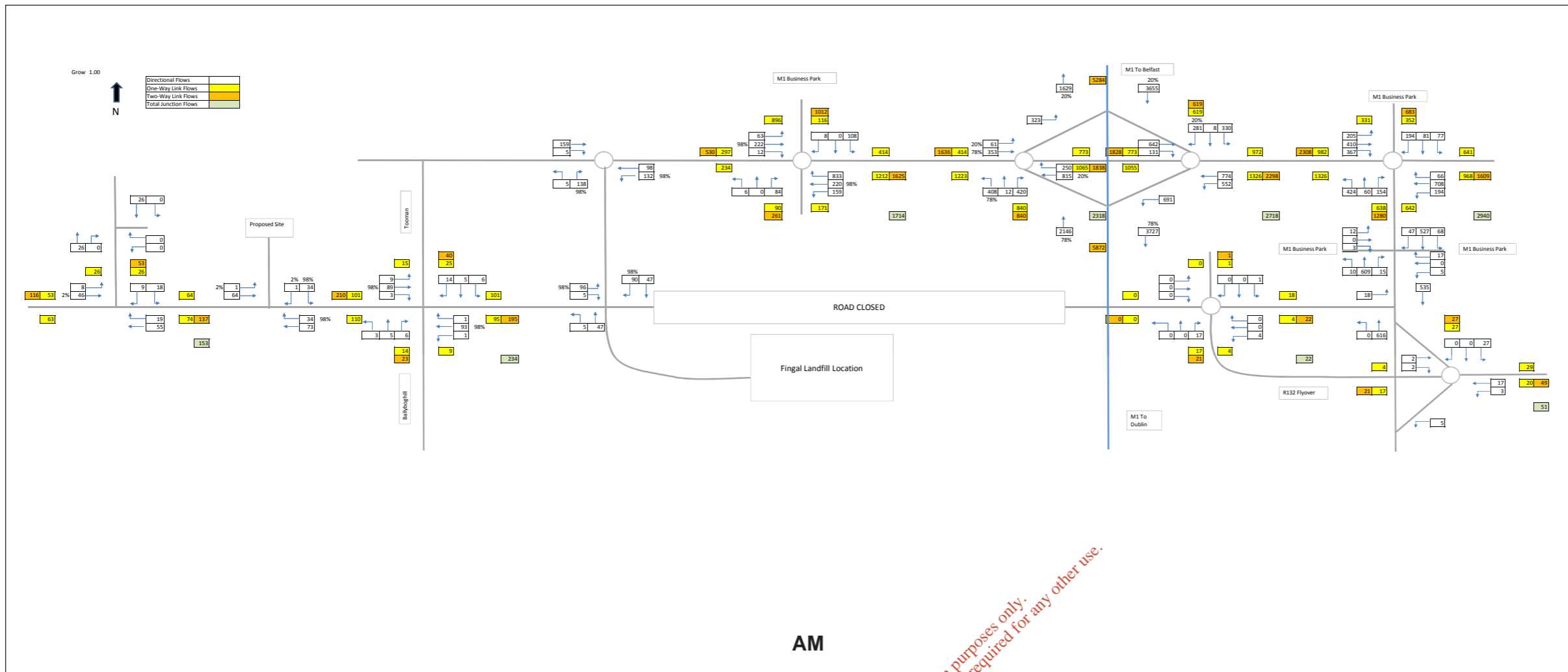

AM

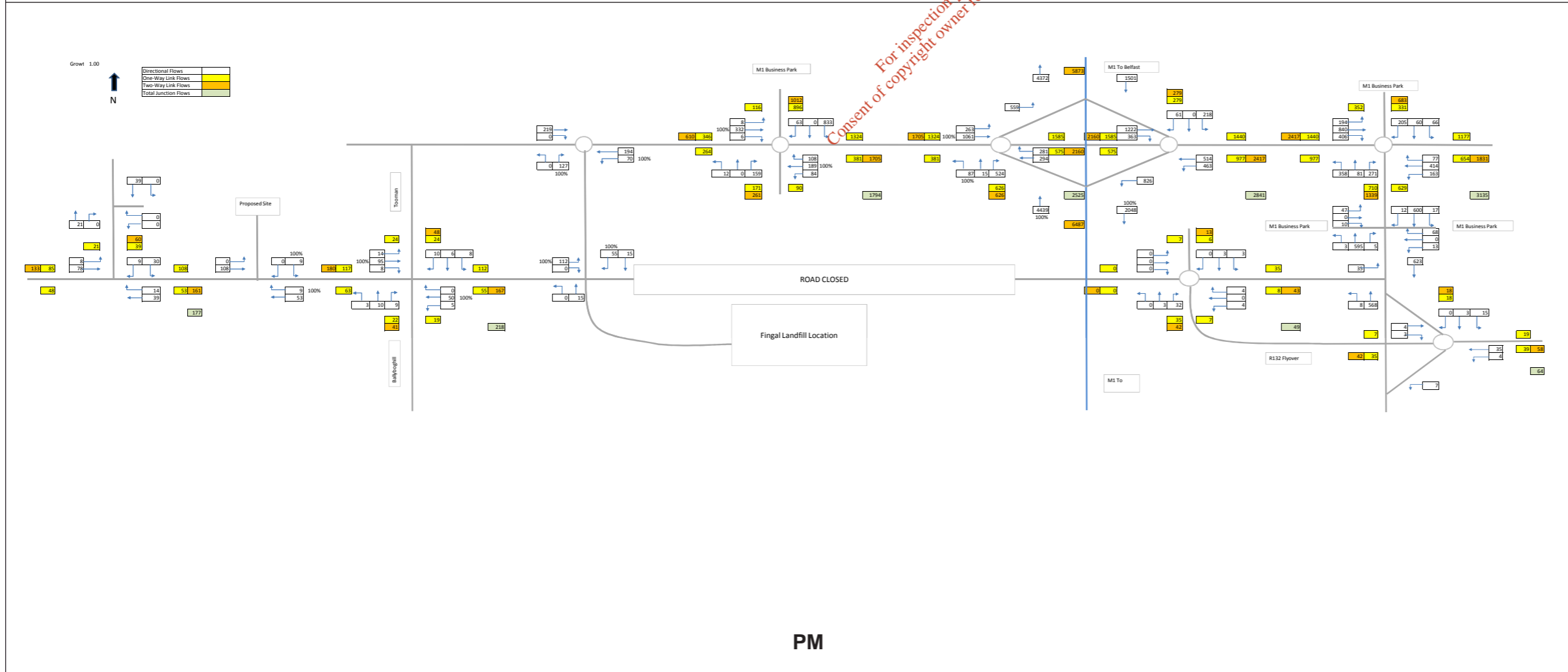

PM

For inspection purposes only.
Consent of copyright owner required for any other use.

ARUP









MEHL Integrated Waste Management Facility
Hollywood Great, Nags Head, Naul, Co Dublin

2024 Do Something, With Fingal, Traffic Flows

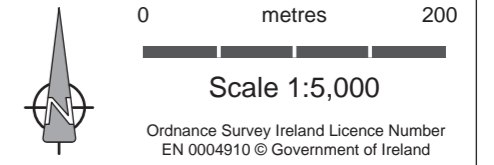
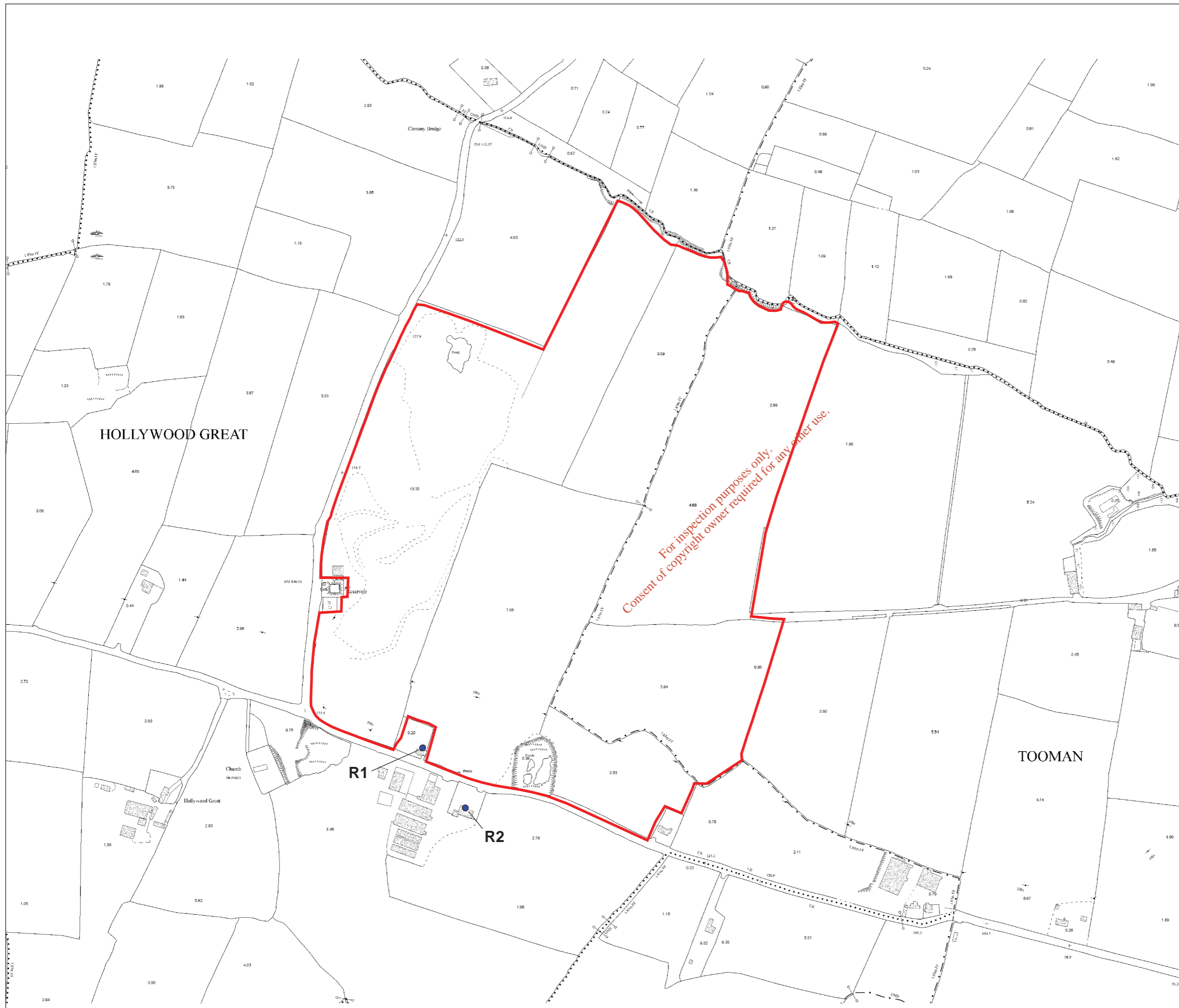
December 2010 Figure 8.12



Legend

- MEHL Proposed Planning and Waste Licence Boundary
- Air quality receptor locations

ARUP



MEHL Integrated Waste Management Facility
 Hollywood Great, Nags Head, Naul, Co Dublin

Air Quality Receptor Locations

December 2010

Figure 9.1

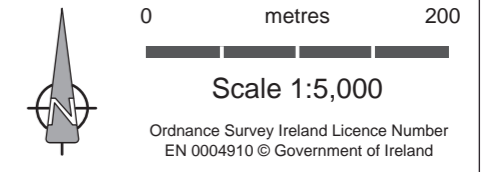

Legend

- MEHL Proposed Planning and Waste Licence Boundary
- Noise Monitoring Location



MEHL Integrated Waste Management Facility
 Hollywood Great, Nags Head, Naul, Co Dublin

Baseline Noise Monitoring Locations

December 2010

Figure 11.1

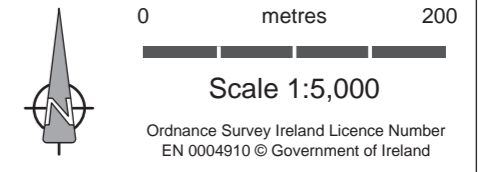
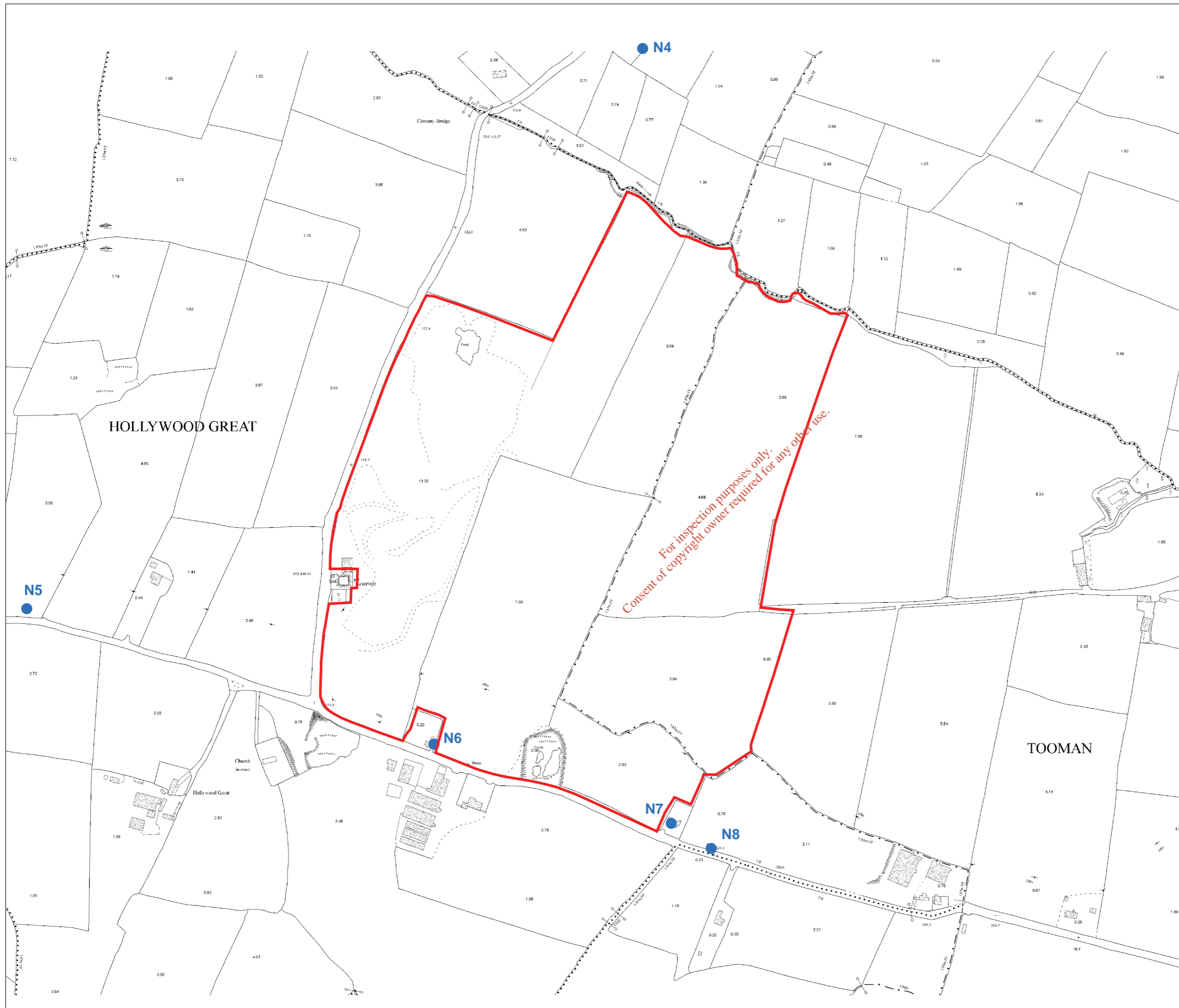

- Legend**
- MEHL Proposed Planning and Waste Licence Boundary
 - Noise Monitoring Location



ARUP



MEHL Integrated Waste Management Facility
 Hollywood Great, Nags Head, Naul, Co Dublin

Annual Waste Licence Noise Monitoring Locations

December 2010

Figure 11.2

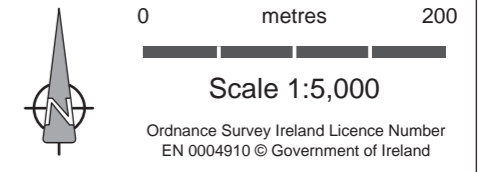
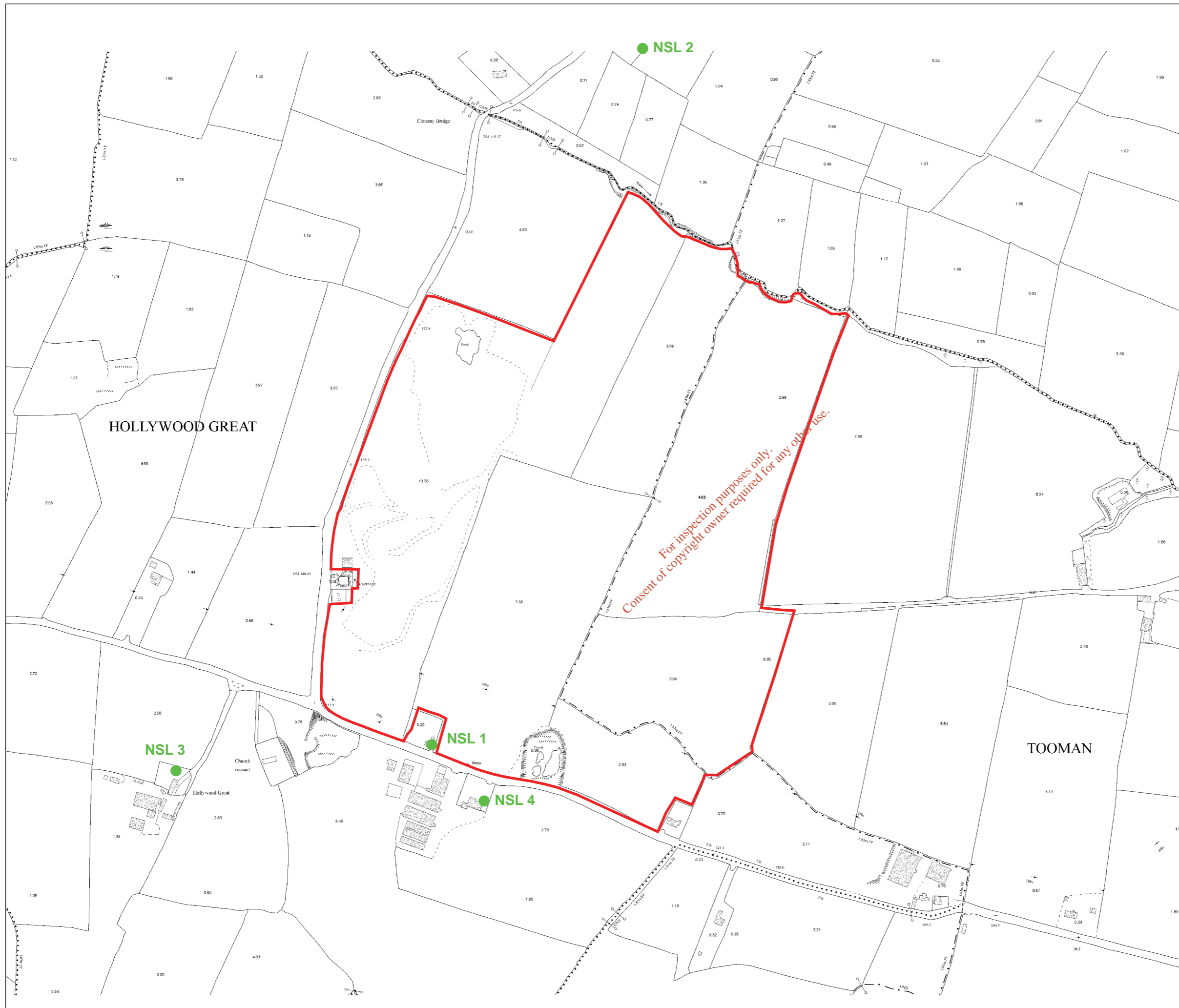

- Legend**
- MEHL Proposed Planning and Waste Licence Boundary
 - Noise Assessment Location



MEHL Integrated Waste Management Facility
 Hollywood Great, Nags Head, Naul, Co Dublin

Noise Assessment Locations

December 2010 Figure 11.3



LEGEND

-  MEHL Proposed Planning and Waste Licence Site Boundary
-  Quarried out area
-  Major ridgeline
-  Minor ridgeline
-  500 m from site boundary
-  Woodland/ scrub
-  Residential Property Group A
-  Residential Property Group B
-  Residential Property Group C
-  Residential Property Group D
-  Individual Properties denoted as circle (Colour refers to group) (Properties A-L refer to Chapter 12 EIS)
-  Agricultural lands
-  Golf Course
-  Glimpsed view from County road



Not to Scale

Ordnance Survey Ireland Licence Number EN 0004910 © Government of Ireland



BRADY SHIPMAN MARTIN
..... always developing new ideas

ARUP



MANAHAN PLANNERS
Chartered Town Planning Consultants

patel tonra ltd
environmental solutions



Murphy Environmental Hollywood Ltd

MEHL Integrated Waste Management Facility
Hollywood Great, Nags Head, Naul, Co Dublin



Landscape and Visual Context

December 2010

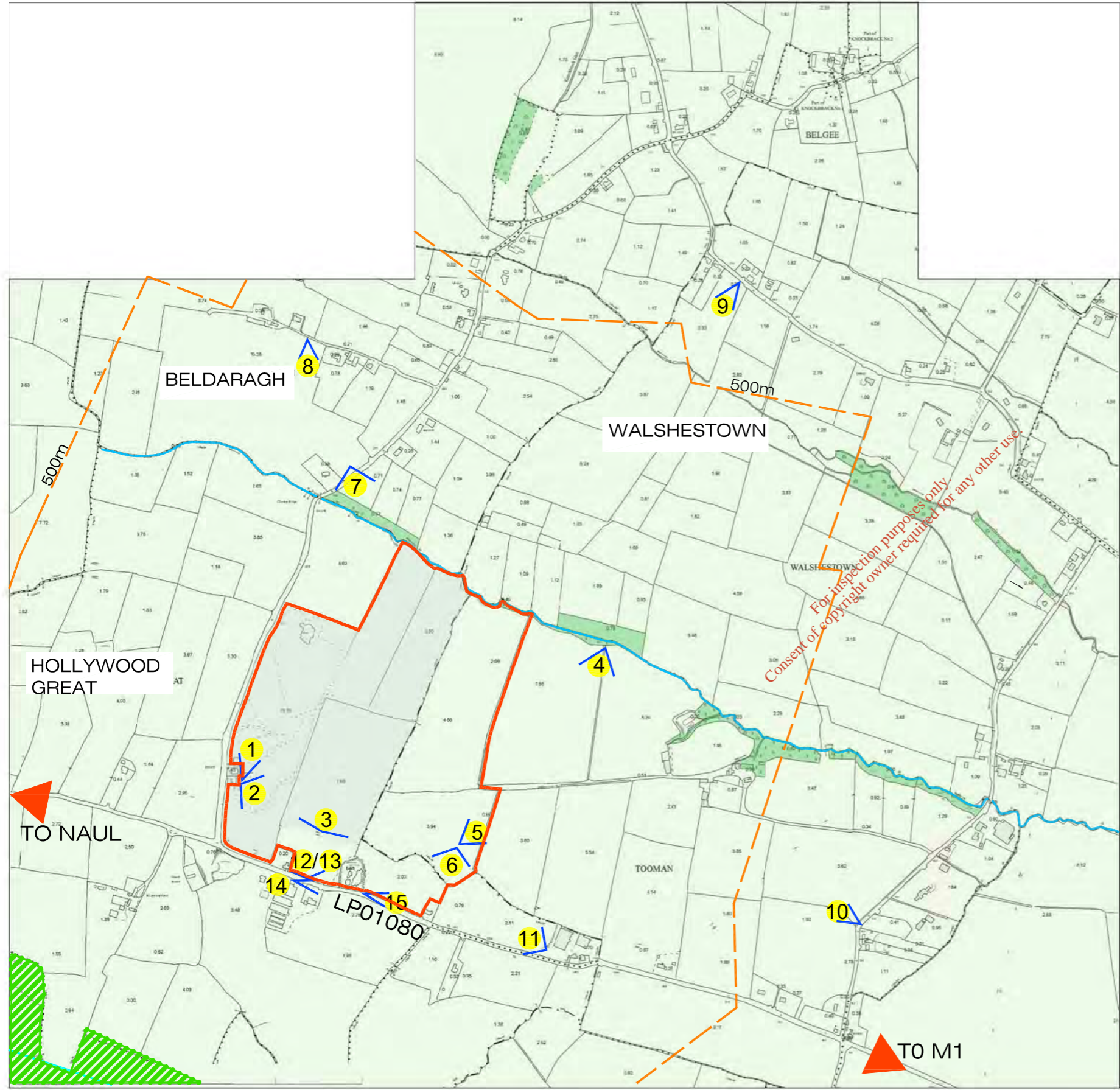
Figure 12.1

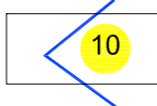

LEGEND

-  MEHL Proposed Planning and Waste Licence Site Boundary
-  500mm from site boundary
-  Photo-view locations

Note : Photo-views 1-15 refer to photographic plates Figures 12.2-12.6.



Not to Scale

Ordnance Survey Ireland Licence Number EN 0004910 © Government of Ireland



BRADY SHIPMAN MARTIN
..... always developing new ideas

ARUP



MANAHAN PLANNERS
Chartered Town Planning Consultants

patel tonra ltd
environmental solutions



Murphy Environmental Hollywood Ltd

MEHL Integrated Waste Management Facility
Hollywood Great, Nags Head, Naul, Co Dublin

Photo-view

December 2010 Figure 12.2



Photo-view One - Looking North From Southern Part of Site



Photo-view Two- Looking East Towards Irish Sea and Coast



Photo-view Three - Looking North Over Quarry From Southern Part of Site



BRADY SHIPMAN MARTIN
..... always developing new ideas

ARUP



patel tonra ltd
environmental solutions

MANAHAN
PLANNERS
Chartered
Town Planning
Consultants



Murphy Environmental
Hollywood Ltd

MEHL Integrated
Waste Management Facility
Hollywood Great, Nags Head, Naul, Co Dublin

Photo-views 1-3 - As Existing

December 2010

Figure 12.3



Photo-view Four - Looking South From North East of Site



Photo-view Five - Looking North East From South East of Site



Photo-view Six - Looking South From Southern Part of Site



ARUP



MEHL Integrated
Waste Management Facility
Hollywood Great, Nags Head, Naul, Co Dublin

Photo-views - 4-6 As Existing

December 2010 Figure 12.4



Photo-view Seven - Looking South East From Local Road North of Site



Photo-view Eight - Looking South From Local Road North West of Site



Photo-view Nine - Looking South West From Local Road North of Site



BRADY SHIPMAN MARTIN
..... always developing new ideas

ARUP



patel tonra ltd
environmental solutions

MANAHAN
PLANNERS
Chartered
Town Planning
Consultants



Murphy Environmental
Hollywood Ltd

MEHL Integrated
Waste Management Facility
Hollywood Great, Nags Head, Naul, Co Dublin

Photo-views 7-9- As Existing

December 2010

Figure 12.5

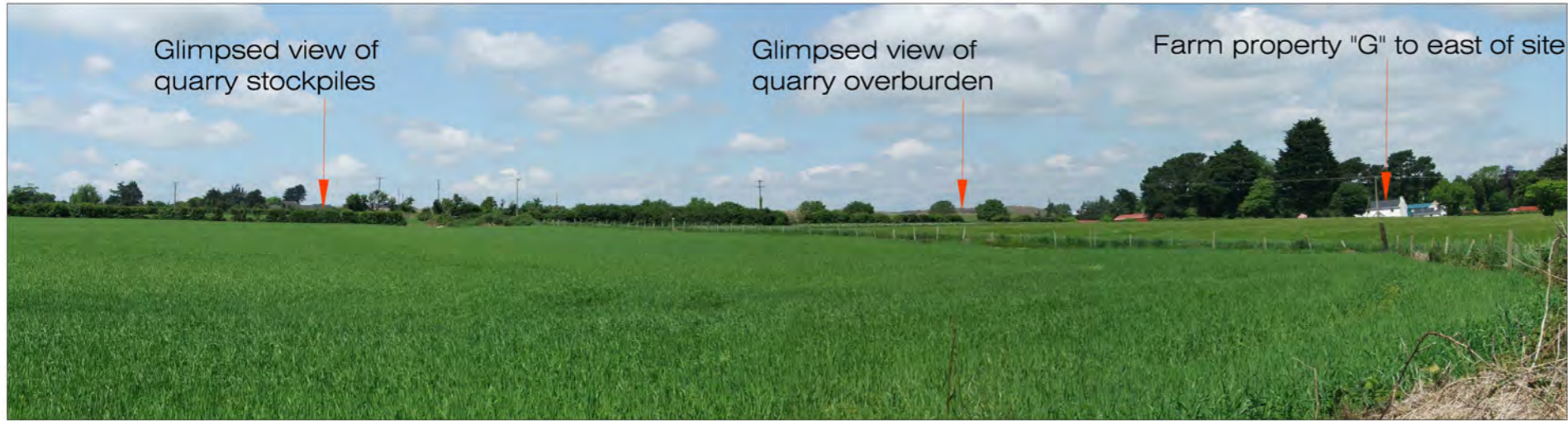

Photo-view Ten - Looking North West From Local Road East of Site



Photo-view Eleven - Looking North West From Local Road to South of Site



Photo-view Twelve - Property to South of Site



ARUP



MEHL Integrated
Waste Management Facility
Hollywood Great, Nags Head, Naul, Co Dublin

Photo-views 10-12 - As Existing

December 2010 Figure 12.6



Photo-view Thirteen - View Through Gate on Local Road to South of Site



Photo-view Fourteen - Local Road to South of Site



Photo-view Fifteen - Local Road to South of Site Near Proposed Site Entrance



ARUP



MEHL Integrated
Waste Management Facility
Hollywood Great, Nags Head, Naul, Co Dublin

Photo-views 13-15 - As Existing

December 2010 Figure 12.7

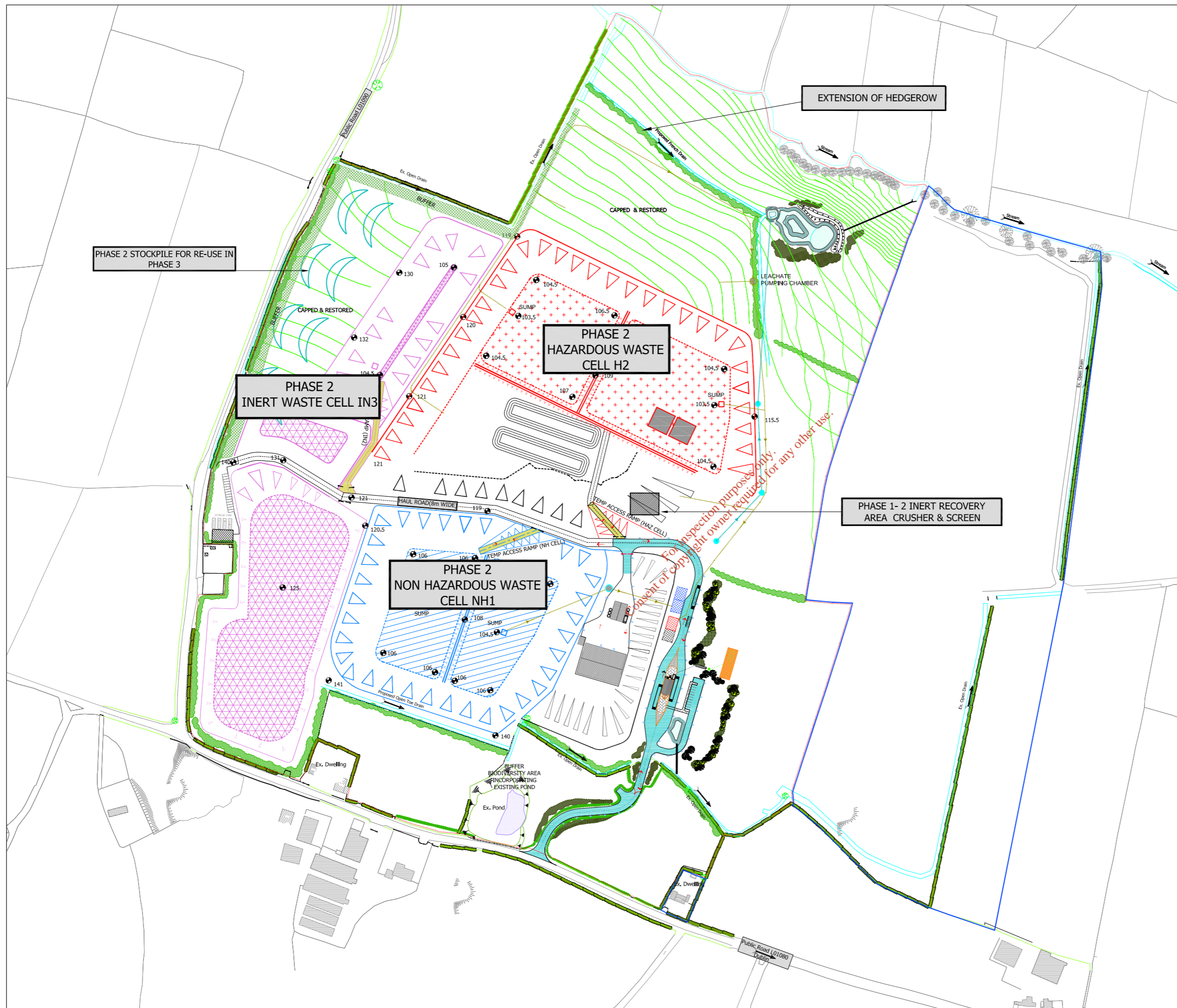

Not to Scale

Ordnance Survey Ireland Licence Number
EN 0004910 © Government of Ireland



BRADY SHIPMAN MARTIN
..... always developing new ideas

ARUP



**MANAHAN
PLANNERS**
Chartered
Town Planning
Consultants



**Murphy Environmental
Hollywood Ltd**

MEHL Integrated
Waste Management Facility
Hollywood Great, Nags Head, Naul, Co Dublin

**Phase 2 Restoration Landscape
Proposals**

December 2010

Figure 12.9

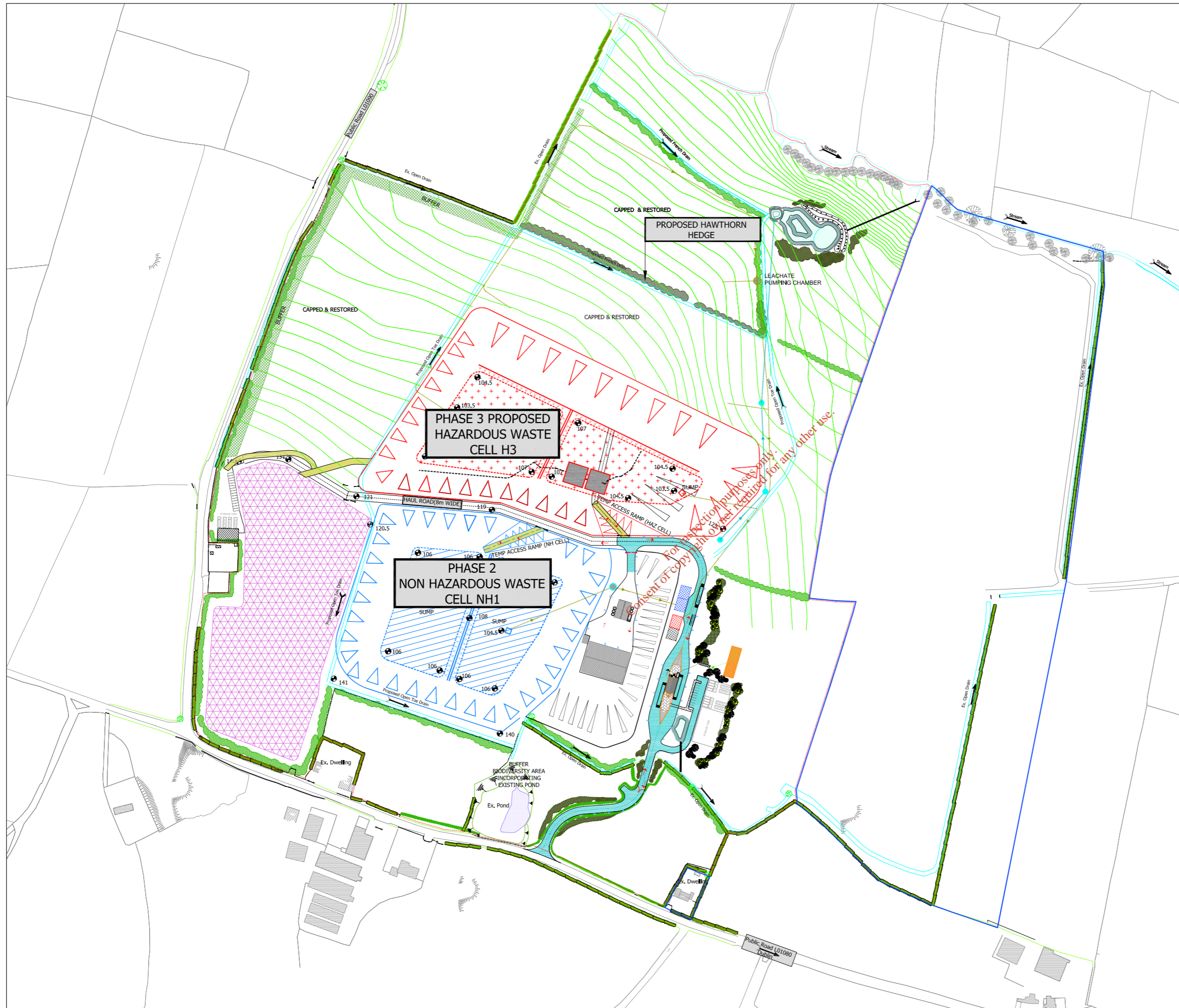

Not to Scale

Ordnance Survey Ireland Licence Number
EN 0004910 © Government of Ireland



BRADY SHIPMAN MARTIN
..... always developing new ideas

ARUP



**MANAHAN
PLANNERS**
Chartered
Town Planning
Consultants

patel tonra ltd
environmental solutions



**Murphy Environmental
Hollywood Ltd**

MEHL Integrated
Waste Management Facility
Hollywood Great, Nags Head, Naul, Co Dublin

**Phase 3 Restoration Landscape
Proposals**

December 2010

Figure 12.10

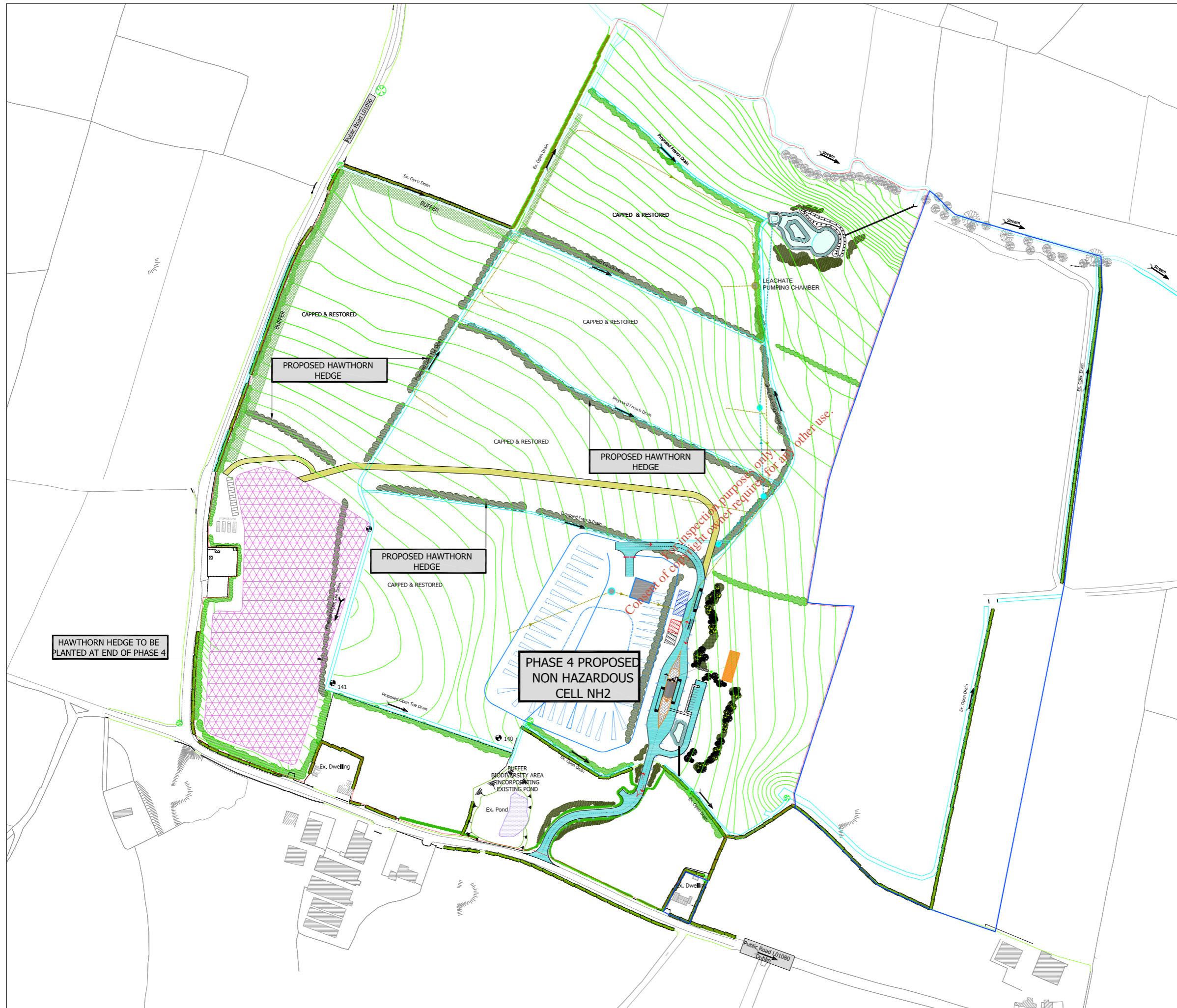

Not to Scale

Ordnance Survey Ireland Licence Number
EN 0004910 © Government of Ireland



BRADY SHIPMAN MARTIN
..... always developing new ideas

ARUP



**MANAHAN
PLANNERS**
Chartered
Town Planning
Consultants

patel tonra ltd
environmental solutions



**Murphy Environmental
Hollywood Ltd**

MEHL Integrated
Waste Management Facility
Hollywood Great, Nags Head, Naul, Co Dublin

**Phase 4 Restoration Landscape
Proposals**

December 2010

Figure 12.11

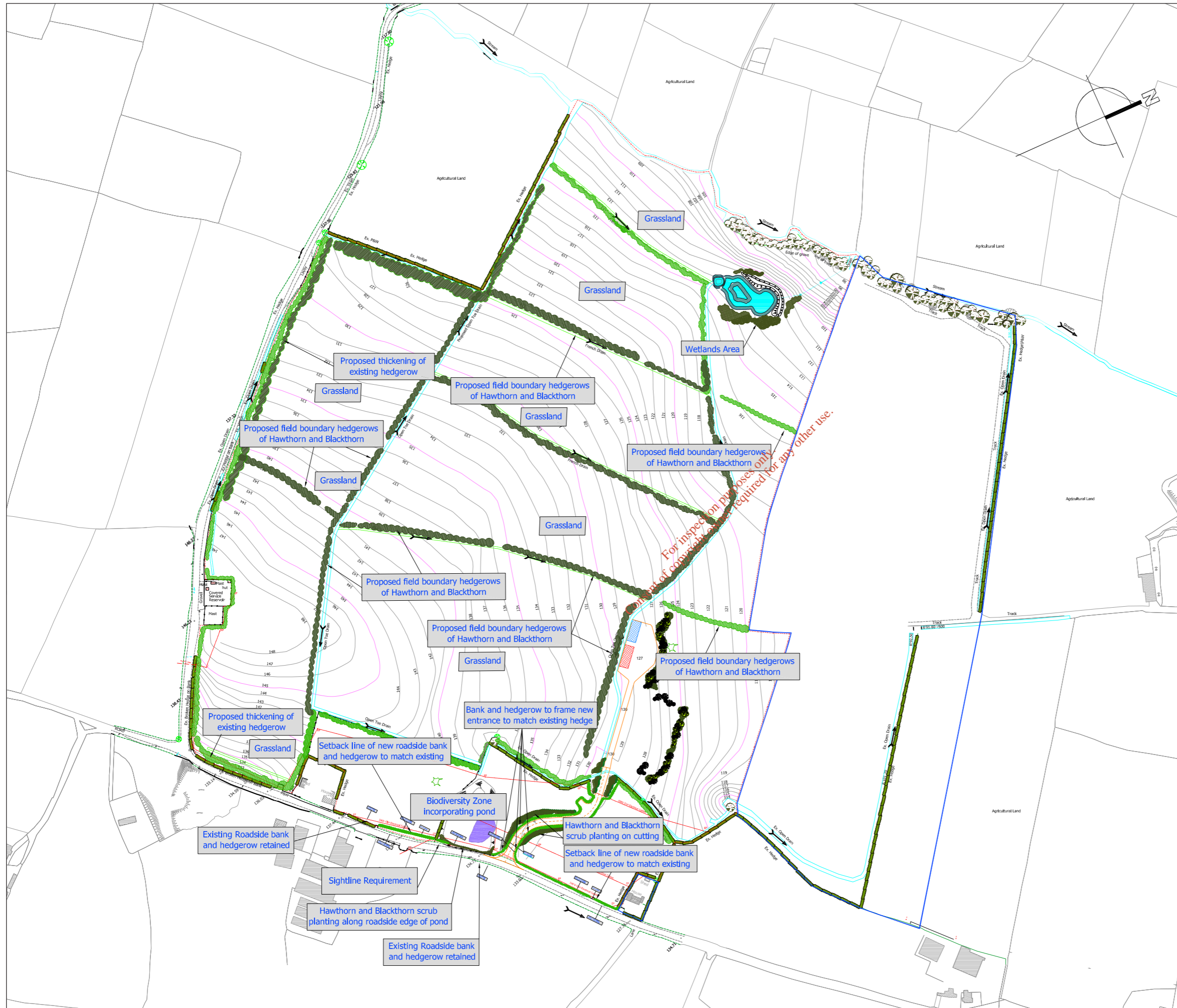

Not to Scale

Ordnance Survey Ireland Licence Number
EN 0004910 © Government of Ireland



BRADY SHIPMAN MARTIN
..... always developing new ideas

ARUP



MANAHAN PLANNERS
Chartered
Town Planning
Consultants

patel tonra ltd
environmental solutions



**Murphy Environmental
Hollywood Ltd**

MEHL Integrated
Waste Management Facility
Hollywood Great, Nags Head, Naul, Co Dublin

**Restoration Landscape
Proposals**

December 2010

Figure 12.12

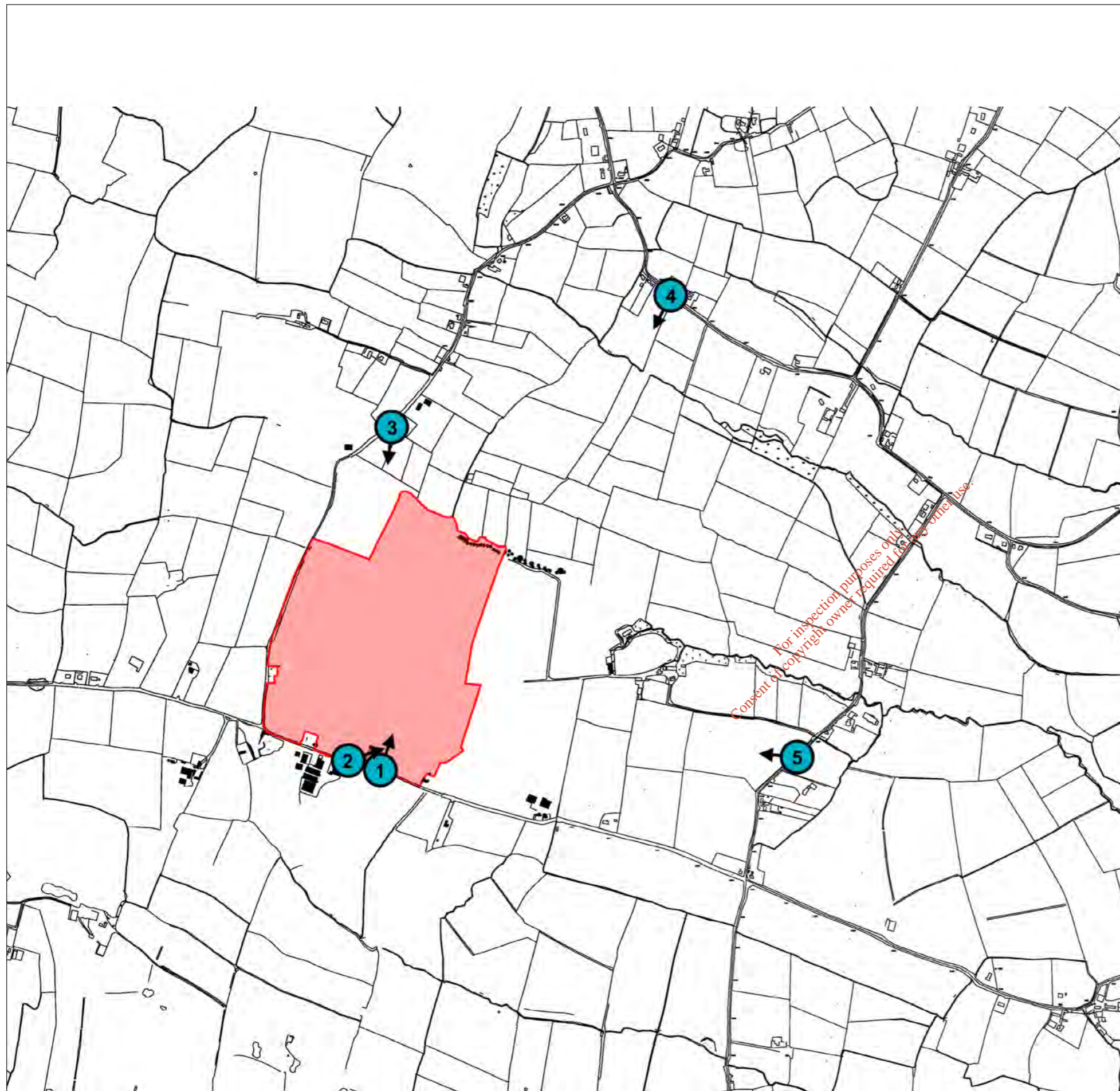

Not to Scale

Ordnance Survey Ireland Licence Number
EN 0004910 © Government of Ireland

LEGEND:

- The Site
- 1 ← Photomontage Location



BRADY SHIPMAN MARTIN
..... always developing new ideas

ARUP



patel tonra ltd
environmental solutions

MANAHAN PLANNERS
Chartered
Town Planning
Consultants



**Murphy Environmental
Hollywood Ltd**

MEHL Integrated
Waste Management Facility
Hollywood Great, Nags Head, Naul, Co Dublin

Photomontage Location Plan

December 2010 Figure 12.13