



Greenport Environmental Ltd.
c/o Mr. Binman,
Luddenmore,
Grange,
Kilmallock,
Co. Limerick.

Administration,
Licensing Unit,
Office of Climate Control, Licensing & Resource Use,
Environmental Protection Agency,
Headquarters,
P.O. Box 3000,
Johnstown Castle Estate,
Co. Wexford.

19th September, 2011

Your Ref: W0271-01, Waste Licence Application by Greenport Environmental Ltd.

Dear Sir/Madam,

Please find enclosed further information regarding the proposed emissions to sewer:

1. Submission to Limerick Co Council detailing the proposed wwtp system, associated discharges and proposed connection to the existing effluent pipeline.
2. Associated response from Limerick Co Council

As required, the two hard copies (1 original and 1 copy) and two electronic copies are enclosed.

If you require any further information or clarification, please do not hesitate to contact me.

Yours sincerely,

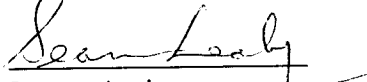
Seamus Leahy,
Environment Manager,
Greenport Environmental Ltd.

For inspection purposes only.
Consent of copyright owner required for any other use.

Seamus Leahy

From: Gibbons Samantha [sgibbons@limerickcoco.ie]
Sent: 08 September 2011 09:51
To: Seamus Leahy
Subject: RE: Message from Samantha Gibbons Limerick County Council

Seamus,
I am emailing you to confirm that you do not require a discharge licence under Section of the Water Pollution Acts 1977-2007 where a waste licence has been granted to you by the EPA.
Regards,
Samantha Gibbons

Samantha Gibbons
Assistant Engineer
Environment Section
Limerick County Council
Ed. Rd. P.O. 875
Limerick, Co. Limerick
Tel: 061-494008

From: Seamus Leahy [mailto:seamus.leahy@mrbinman.com]
Sent: 07 September 2011 17:47
To: Gibbons Samantha
Subject: RE: Message from Samantha Gibbons Limerick County Council

Samantha,

I tried calling you back and left a message on your phone. For EPA Waste Licensed facilities, please find below the relevant legislation (Section 40(5)(b) of the Waste Management Act) which supersedes Section 4 of the Water Pollution Act as referred to in your e-mail. As a waste facility, the Greenport development and all associated emissions will, subject to approval, be licensed by the EPA under a Waste Licence. Therefore a Local Authority Discharge Licence is not required under Section 4. This issue was raised and clarified previously during the planning process with Limerick County Council.

Under the **Article 40 (5) Waste Management Act 1996**, it states:
"Where a waste licence is granted in relation to an activity, a licence under--

(b) section 4 or 16 of the Local Government (Water Pollution) Act, 1977, or

(c) section 171 of the Fisheries (Consolidation) Act, 1959,

shall not be granted in relation to such an activity, and any such licence that is in force in relation to such an activity shall thereupon cease to have effect in relation thereto."

As indicated previously the AFSC discharge will be monitored separately under their Local Authority Discharge Licence and the Greenport discharge will be monitored separately under the EPA Waste Licence.

As requested, can you please confirm in writing that all is in order in this regard?

If you require further clarification, please do not hesitate to contact me. I will try to call you in the morning to discuss further.

Regards,

Seamus
Tel: 061 359053

From: Gibbons Samantha [mailto:sgibbons@limerickcoco.ie]
Sent: 07 September 2011 12:55
To: Seamus Leahy
Subject: Message from Samantha Gibbons Limerick County Council
Importance: High

Seamus,

I tried to call you today and yesterday in relation to your letter received on the 4th August 2011. Following discussions with Anne Goggin, Senior Executive Engineer it has been stated that you do require a discharge licence as you are discharging to waters and not to a sewer and therefore the discharge from your premises requires a Discharge Licence under Section 4 of the Water Pollution Acts 1977-2007.

If you require any further information please contact me on 061-496595. Please note that I will be out of the office from this Friday, 9th September till Tuesday, 27th September,

Regards,
Samantha Gibbons

Samantha Gibbons
Assistant Engineer
Environment Section
Limerick County Council
Tel: 061-496595
Fax: 061-496008

** Email Scanned by Spam and Virus Scanning Service **

** Email Scanned by Spam and Virus Scanning Service **

For inspection purposes only.
Consent of copyright owner required for any other use.



greenport environmental

Ms. Samantha Gibbons,
Environment Section,
Limerick Co Council,
County Hall,
Dooradoyle,
Co. Limerick.

3rd August, 2011

RE: Greenport Environmental Ltd AD/Composting Facility

Dear Samantha,

Further to my recent call regarding the foul sewer discharge for our proposed development at Durnish, Foynes, I now submit further information for your attention and consideration.

Greenport Environmental Ltd. (GEL) is proposing to develop an Anaerobic Digestion/Composting facility at our site in Durnish, Foynes. The emissions from the facility will be subject to a Waste Licence issued by the Environmental Protection Agency and will be subject to conditions imposed by that Licence.

Regarding emissions to sewer, the discharge will consist of a treated effluent discharge from a proprietary waste water treatment system designed to treat foul sewage from the office area (toilets, etc) of this facility only. There will be no process discharges, roof water or storm water discharges to this system. The proposed mechanical wastewater treatment system is designed to ensure the effluent will be treated to the equivalent limits imposed in the discharge licence issued to the neighbouring facility, Atlantic Fuel Supply Company (AFSC). Details of the proposed proprietary system are attached (Appendix A). This system is replacing an existing septic tank located at the existing premises.

It is proposed to discharge the effluent from the upgraded treatment system to an existing foul sewer pipeline within Foynes Port. This existing foul sewer was installed and is owned by Atlantic Fuel Supply Company Ltd. It was verified by Civil Engineering Consultants (employed by both AFSC and GEL), that the pipeline is adequately sized to accept the discharge from GEL (Reference Appendix B for report and drawing).

The current discharge from AFSC premises is licensed by Limerick County Council under Register No. W.109. There will be no material change in the quality or quantity of the trade effluent being discharged from the AFSC premises as specified in the licence application form submitted to Limerick County Council on 12th December 2008. As a result of this development by Greenport Environmental Ltd, no constituent of the effluent from the AFSC premises shall be discharged in such quantities as would



greenport environmental

exceed those concentration limits imposed for the specific substance in national or international legislation. The discharges from AFSCS will continue to be monitored in accordance with the conditions of Licence W.109.

It is agreed by both GEL and AFSC that separate sampling chambers, upstream of the proposed connection point will be put in place to allow independent monitoring of the discharges from each premises and to ensure compliance with the conditions of the respective licences.

Please find attached details of the proposed development for your consideration but please do not hesitate to contact me should you require further information/clarification.

I would appreciate it if you could please acknowledge receipt of this correspondence and confirm that this is acceptable to Limerick Co Council?

If you require further information, please do not hesitate to contact me.

Yours sincerely,

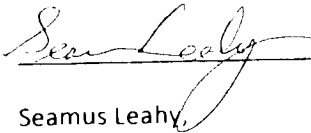

Seamus Leahy

Environment Manager,
Greenport Environmental Ltd,
c/o Mr Binman,
Luddenmore,
Grange,
Kilmallock,
Co. Limerick.

For inspection purposes only.
Consent of copyright owner required for any other use.



greenport environmental

Appendix A

*For inspection purposes only.
Consent of copyright owner required for any other use.*



greenport environmental

Appendix B

*For inspection purposes only.
Consent of copyright owner required for any other use.*

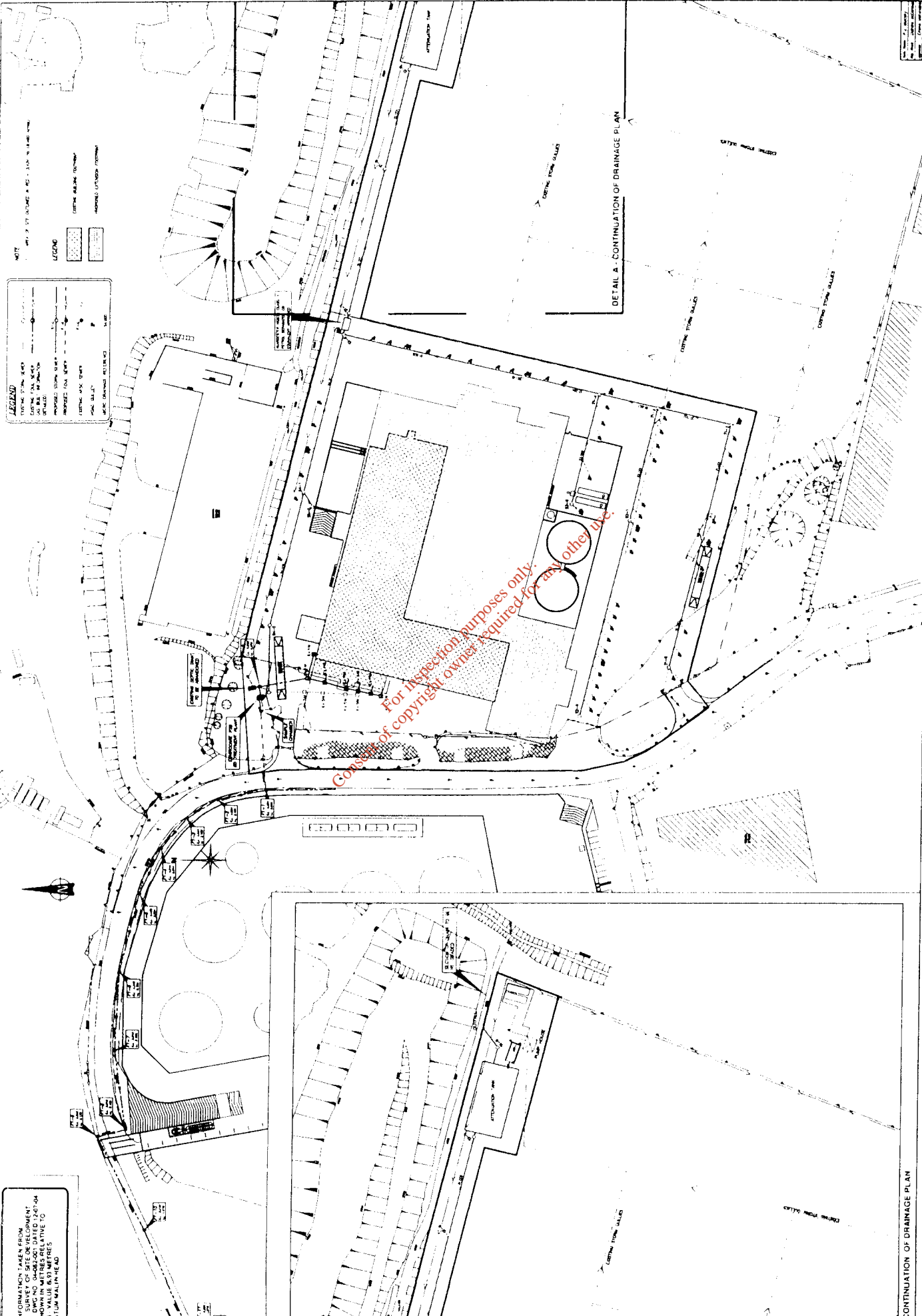

NOTE
 1. ALL WORK TO BE DONE IN ACCORDANCE WITH THE SPECIFICATIONS AND CONDITIONS OF CONTRACT.
 2. THE CONTRACTOR SHALL BE RESPONSIBLE FOR OBTAINING ALL NECESSARY PERMITS AND APPROVALS FROM THE RELEVANT AUTHORITIES.
 3. THE CONTRACTOR SHALL MAINTAIN ACCESS TO ALL ADJACENT PROPERTIES AT ALL TIMES.
 4. THE CONTRACTOR SHALL BE RESPONSIBLE FOR THE PROTECTION OF ALL EXISTING UTILITIES AND STRUCTURES.
 5. THE CONTRACTOR SHALL MAINTAIN A RECORD OF ALL WORK DONE AND SUBMIT IT TO THE ENGINEER AT THE END OF THE PROJECT.

LEGEND

EXISTING GULLY	PROPOSED GULLY	LETTERING THE GULLY	LETTERING THE BUILDING
EXISTING MANHOLE	PROPOSED MANHOLE	LETTERING THE MANHOLE	LETTERING THE BUILDING
EXISTING STREET LIGHT	PROPOSED STREET LIGHT	LETTERING THE STREET LIGHT	LETTERING THE BUILDING
EXISTING DRIVEWAY	PROPOSED DRIVEWAY	LETTERING THE DRIVEWAY	LETTERING THE BUILDING
EXISTING FENCE	PROPOSED FENCE	LETTERING THE FENCE	LETTERING THE BUILDING
EXISTING WALL	PROPOSED WALL	LETTERING THE WALL	LETTERING THE BUILDING
EXISTING CURB	PROPOSED CURB	LETTERING THE CURB	LETTERING THE BUILDING
EXISTING PAVEMENT	PROPOSED PAVEMENT	LETTERING THE PAVEMENT	LETTERING THE BUILDING
EXISTING PLANTING	PROPOSED PLANTING	LETTERING THE PLANTING	LETTERING THE BUILDING
EXISTING LANDSCAPE	PROPOSED LANDSCAPE	LETTERING THE LANDSCAPE	LETTERING THE BUILDING

LEGEND

EXISTING GULLY	PROPOSED GULLY	LETTERING THE GULLY	LETTERING THE BUILDING
EXISTING MANHOLE	PROPOSED MANHOLE	LETTERING THE MANHOLE	LETTERING THE BUILDING
EXISTING STREET LIGHT	PROPOSED STREET LIGHT	LETTERING THE STREET LIGHT	LETTERING THE BUILDING
EXISTING DRIVEWAY	PROPOSED DRIVEWAY	LETTERING THE DRIVEWAY	LETTERING THE BUILDING
EXISTING FENCE	PROPOSED FENCE	LETTERING THE FENCE	LETTERING THE BUILDING
EXISTING WALL	PROPOSED WALL	LETTERING THE WALL	LETTERING THE BUILDING
EXISTING CURB	PROPOSED CURB	LETTERING THE CURB	LETTERING THE BUILDING
EXISTING PAVEMENT	PROPOSED PAVEMENT	LETTERING THE PAVEMENT	LETTERING THE BUILDING
EXISTING PLANTING	PROPOSED PLANTING	LETTERING THE PLANTING	LETTERING THE BUILDING
EXISTING LANDSCAPE	PROPOSED LANDSCAPE	LETTERING THE LANDSCAPE	LETTERING THE BUILDING

SURVEY INFORMATION TAKEN FROM
 SURVEYS SURVEY OF SITE DEVELOPMENT
 SURVEY NO. 0488-002 DATED 24/11/04
 SURVEY NO. 0488-003 DATED 24/11/04
 SURVEY NO. 0488-004 DATED 24/11/04
 SURVEY NO. 0488-005 DATED 24/11/04
 SURVEY NO. 0488-006 DATED 24/11/04
 SURVEY NO. 0488-007 DATED 24/11/04
 SURVEY NO. 0488-008 DATED 24/11/04
 SURVEY NO. 0488-009 DATED 24/11/04
 SURVEY NO. 0488-010 DATED 24/11/04
 SURVEY NO. 0488-011 DATED 24/11/04
 SURVEY NO. 0488-012 DATED 24/11/04
 SURVEY NO. 0488-013 DATED 24/11/04
 SURVEY NO. 0488-014 DATED 24/11/04
 SURVEY NO. 0488-015 DATED 24/11/04
 SURVEY NO. 0488-016 DATED 24/11/04
 SURVEY NO. 0488-017 DATED 24/11/04
 SURVEY NO. 0488-018 DATED 24/11/04
 SURVEY NO. 0488-019 DATED 24/11/04
 SURVEY NO. 0488-020 DATED 24/11/04
 SURVEY NO. 0488-021 DATED 24/11/04
 SURVEY NO. 0488-022 DATED 24/11/04
 SURVEY NO. 0488-023 DATED 24/11/04
 SURVEY NO. 0488-024 DATED 24/11/04
 SURVEY NO. 0488-025 DATED 24/11/04
 SURVEY NO. 0488-026 DATED 24/11/04
 SURVEY NO. 0488-027 DATED 24/11/04
 SURVEY NO. 0488-028 DATED 24/11/04
 SURVEY NO. 0488-029 DATED 24/11/04
 SURVEY NO. 0488-030 DATED 24/11/04
 SURVEY NO. 0488-031 DATED 24/11/04
 SURVEY NO. 0488-032 DATED 24/11/04
 SURVEY NO. 0488-033 DATED 24/11/04
 SURVEY NO. 0488-034 DATED 24/11/04
 SURVEY NO. 0488-035 DATED 24/11/04
 SURVEY NO. 0488-036 DATED 24/11/04
 SURVEY NO. 0488-037 DATED 24/11/04
 SURVEY NO. 0488-038 DATED 24/11/04
 SURVEY NO. 0488-039 DATED 24/11/04
 SURVEY NO. 0488-040 DATED 24/11/04
 SURVEY NO. 0488-041 DATED 24/11/04
 SURVEY NO. 0488-042 DATED 24/11/04
 SURVEY NO. 0488-043 DATED 24/11/04
 SURVEY NO. 0488-044 DATED 24/11/04
 SURVEY NO. 0488-045 DATED 24/11/04
 SURVEY NO. 0488-046 DATED 24/11/04
 SURVEY NO. 0488-047 DATED 24/11/04
 SURVEY NO. 0488-048 DATED 24/11/04
 SURVEY NO. 0488-049 DATED 24/11/04
 SURVEY NO. 0488-050 DATED 24/11/04
 SURVEY NO. 0488-051 DATED 24/11/04
 SURVEY NO. 0488-052 DATED 24/11/04
 SURVEY NO. 0488-053 DATED 24/11/04
 SURVEY NO. 0488-054 DATED 24/11/04
 SURVEY NO. 0488-055 DATED 24/11/04
 SURVEY NO. 0488-056 DATED 24/11/04
 SURVEY NO. 0488-057 DATED 24/11/04
 SURVEY NO. 0488-058 DATED 24/11/04
 SURVEY NO. 0488-059 DATED 24/11/04
 SURVEY NO. 0488-060 DATED 24/11/04
 SURVEY NO. 0488-061 DATED 24/11/04
 SURVEY NO. 0488-062 DATED 24/11/04
 SURVEY NO. 0488-063 DATED 24/11/04
 SURVEY NO. 0488-064 DATED 24/11/04
 SURVEY NO. 0488-065 DATED 24/11/04
 SURVEY NO. 0488-066 DATED 24/11/04
 SURVEY NO. 0488-067 DATED 24/11/04
 SURVEY NO. 0488-068 DATED 24/11/04
 SURVEY NO. 0488-069 DATED 24/11/04
 SURVEY NO. 0488-070 DATED 24/11/04
 SURVEY NO. 0488-071 DATED 24/11/04
 SURVEY NO. 0488-072 DATED 24/11/04
 SURVEY NO. 0488-073 DATED 24/11/04
 SURVEY NO. 0488-074 DATED 24/11/04
 SURVEY NO. 0488-075 DATED 24/11/04
 SURVEY NO. 0488-076 DATED 24/11/04
 SURVEY NO. 0488-077 DATED 24/11/04
 SURVEY NO. 0488-078 DATED 24/11/04
 SURVEY NO. 0488-079 DATED 24/11/04
 SURVEY NO. 0488-080 DATED 24/11/04
 SURVEY NO. 0488-081 DATED 24/11/04
 SURVEY NO. 0488-082 DATED 24/11/04
 SURVEY NO. 0488-083 DATED 24/11/04
 SURVEY NO. 0488-084 DATED 24/11/04
 SURVEY NO. 0488-085 DATED 24/11/04
 SURVEY NO. 0488-086 DATED 24/11/04
 SURVEY NO. 0488-087 DATED 24/11/04
 SURVEY NO. 0488-088 DATED 24/11/04
 SURVEY NO. 0488-089 DATED 24/11/04
 SURVEY NO. 0488-090 DATED 24/11/04
 SURVEY NO. 0488-091 DATED 24/11/04
 SURVEY NO. 0488-092 DATED 24/11/04
 SURVEY NO. 0488-093 DATED 24/11/04
 SURVEY NO. 0488-094 DATED 24/11/04
 SURVEY NO. 0488-095 DATED 24/11/04
 SURVEY NO. 0488-096 DATED 24/11/04
 SURVEY NO. 0488-097 DATED 24/11/04
 SURVEY NO. 0488-098 DATED 24/11/04
 SURVEY NO. 0488-099 DATED 24/11/04
 SURVEY NO. 0488-100 DATED 24/11/04

DATE	24/11/04
SCALE	1:100
DRAWN BY	[Name]
CHECKED BY	[Name]
APPROVED BY	[Name]

PROJECT INFORMATION
 PROJECT NAME: [Name]
 PROJECT NO.: [Number]
 PROJECT ADDRESS: [Address]
 PROJECT CONTACT: [Name]
 PROJECT PHONE: [Number]
 PROJECT FAX: [Number]
 PROJECT EMAIL: [Email]
 PROJECT WEBSITE: [Website]

DATE	24/11/04
SCALE	1:100
DRAWN BY	[Name]
CHECKED BY	[Name]
APPROVED BY	[Name]

PROJECT INFORMATION
 PROJECT NAME: [Name]
 PROJECT NO.: [Number]
 PROJECT ADDRESS: [Address]
 PROJECT CONTACT: [Name]
 PROJECT PHONE: [Number]
 PROJECT FAX: [Number]
 PROJECT EMAIL: [Email]
 PROJECT WEBSITE: [Website]

DATE	24/11/04
SCALE	1:100
DRAWN BY	[Name]
CHECKED BY	[Name]
APPROVED BY	[Name]

PROJECT INFORMATION
 PROJECT NAME: [Name]
 PROJECT NO.: [Number]
 PROJECT ADDRESS: [Address]
 PROJECT CONTACT: [Name]
 PROJECT PHONE: [Number]
 PROJECT FAX: [Number]
 PROJECT EMAIL: [Email]
 PROJECT WEBSITE: [Website]

DATE	24/11/04
SCALE	1:100
DRAWN BY	[Name]
CHECKED BY	[Name]
APPROVED BY	[Name]

PROJECT INFORMATION
 PROJECT NAME: [Name]
 PROJECT NO.: [Number]
 PROJECT ADDRESS: [Address]
 PROJECT CONTACT: [Name]
 PROJECT PHONE: [Number]
 PROJECT FAX: [Number]
 PROJECT EMAIL: [Email]
 PROJECT WEBSITE: [Website]

JOB: Biogas Composting Facility, Foynes	Job No: 061-306	Page 1 of 1	 Michael Punch & Partners <small>CONSULTING ENGINEERS</small>
SUBJECT: Existing Foul Network Capacity Check	By: F. Judge	Date: 16 October 2009	
	Checked	Date	

Ref	Calculation	Output
	<p><u>Capacity of existing Foul Network:</u></p> <p>Existing Foul Network in Roadway currently services AFSC site only</p> <p>Foul Flow from AFSC consists of discharge from Operations Building via 12 PE treatment plant</p> <p>Max dry weather flow estimated at = 12,000 l/day => 6DWF = 72,000 l/day = 0.83 l/sec</p> <p>Max discharge from Composting Facility via 25PE treatment plant = 25,000 l/day => 6DWF = 150,000 l/day = 1.74 l/sec</p> <p>Therefore total max predicted flow in pipeline (AFSC site & Composting Facility) = 2.57 l/sec</p> <p>Capacity of existing 225mm diameter pipe at gradient of 1:225 = 30 l/sec.</p> <p><u>Therefore there is ample capacity in the existing pipe network to cater for discharges from the proposed development</u></p>	

For inspection purposes only. Consent of copyright owner required for any other use.



O' Sullivan Consulting

professional independent assessment

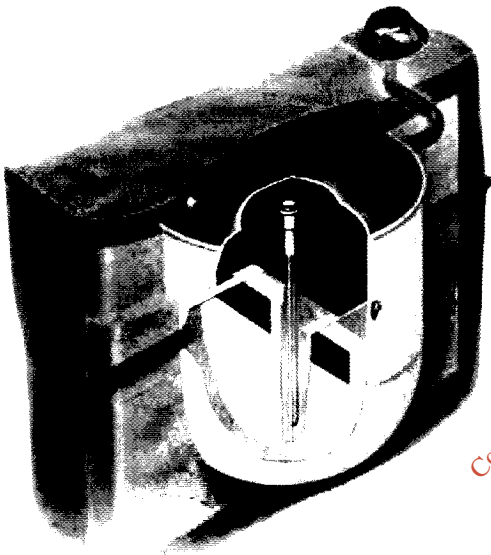

The people to talk to regarding percolation testing, soakage problems and all aspects of sewage treatment, pump stations and storm water disposal products!

- Percolation testing
- Soakage testing
- Consulting service to engineers
- Problem solving for householders experiencing sewage treatment problems
- Pump station advice
- Expertise on all environmental products
- Product Recommendation

*For inspection purposes only
Consent of copyright owner required for any other use*

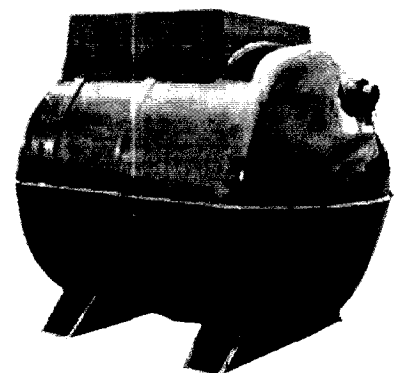
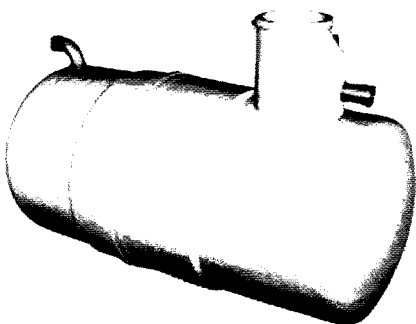



Services Provided:

- **Percolation Testing**
E.P.A standard percolation & soakage testing
- **Site Assessments**
We will assess your site for soakage and water treatment solution
- **Sewage Treatment Proposals**
We will propose a solution
- **Pumping Solutions**
We will propose quality product to cater for your needs.
- **Environmental Products**
We will recommend a creditable product

O' Sullivan Consulting
Rossaneen, Currow, Killarney, Co. Kerry
Tel: 066 9793931
Mobile: 087 2390040
email: info@osullivanconsulting.ie
www.osullivanconsulting.ie

For inspection purposes only.
Consent of copyright owner required for any other use.

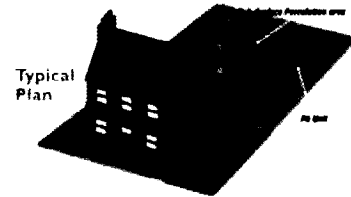

Typical Plan

Typical Percolation Area Layout



Sub-surface Percolation

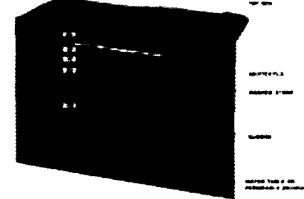

Raised Mounded Percolation

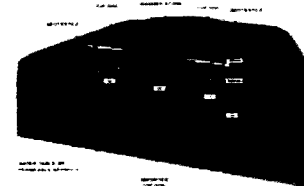

Passmore,

Carson,

Killenzy,

Co. Kerry.

Tel / Fax (066) 9793931

www.osullivanconsulting.ie

e-mail : info@osullivanconsulting.ie

To Whom It May Concern:

I wish to confirm the following as requested by the planning agent in relation to the Greenport project at Foynes.

The Envirocare 25 PE BD will be able to cater for the twenty staff on the site and will have redundant capacity as well.

There will be chemical dosing within this plant also.

The P25 BD holds Irish agreement certification (ref no. 01/0094) and EN 12566/3 certification. This complies with current E.P.A guidelines. It is part of the rules in the E.P.A treatment manual for small communities, business's, leisure centres, and hotels that a permanent staff member on site inspects and minorors the plant regularly and keeps an inspection/ care log which must be available to the local authority for inspection if requested. I recommend an annual service and a nine monthly desludge.

It is also an E.P.A. requirement that a treatment plant service contract is put in place with the supplier at all times.

I enclose an application form for this service contract.

It is also a requirement that the plant be cleaned out every nine months.

I recommend Irish Drain Services for this. Their representative's phone number is (086) 8290839. I enclose their letter and details also

They will do the desludging and are insured and approved.

OSullivan

The treatment standards are as follows from the unit. (P 25 BDG INC DOSING)

Ph	6-9
B.O.D	20mg/l
S.S	30mg/l
Ammonia	5mg/l
Nitrate	5mg/l

Total Phosphorus 1mg/l

Feel free to contact me for any further information.

Your Sincerely,

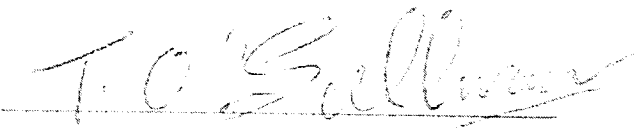

Tim O' Sullivan.
066-9793931
087-6858993
Agent - Munster

For inspection purposes only.
Consent of copyright owner required for any other use.

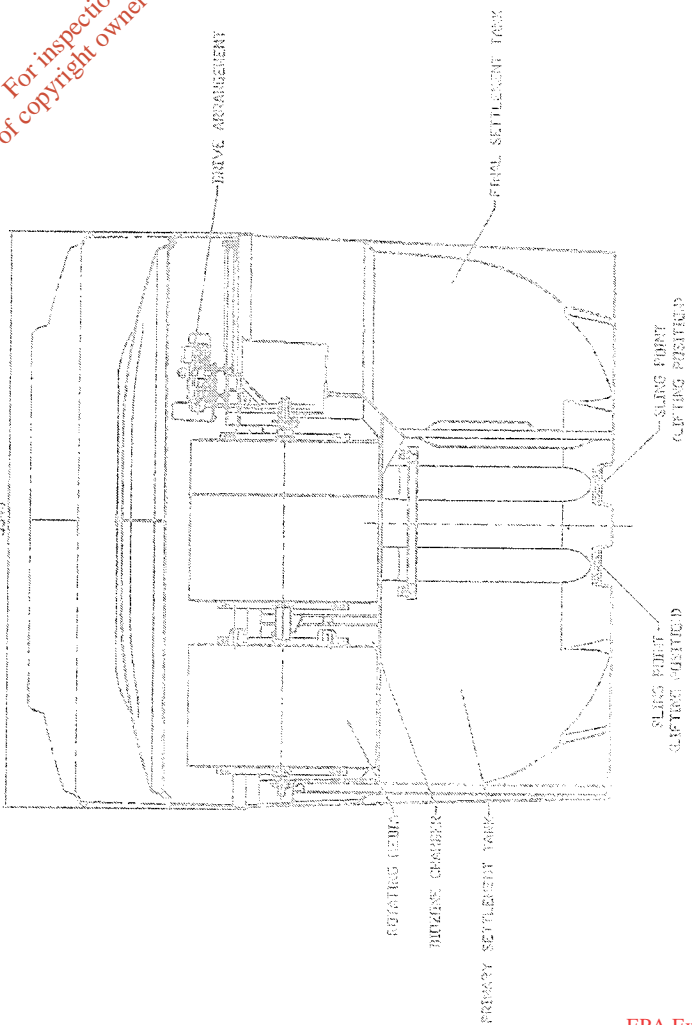
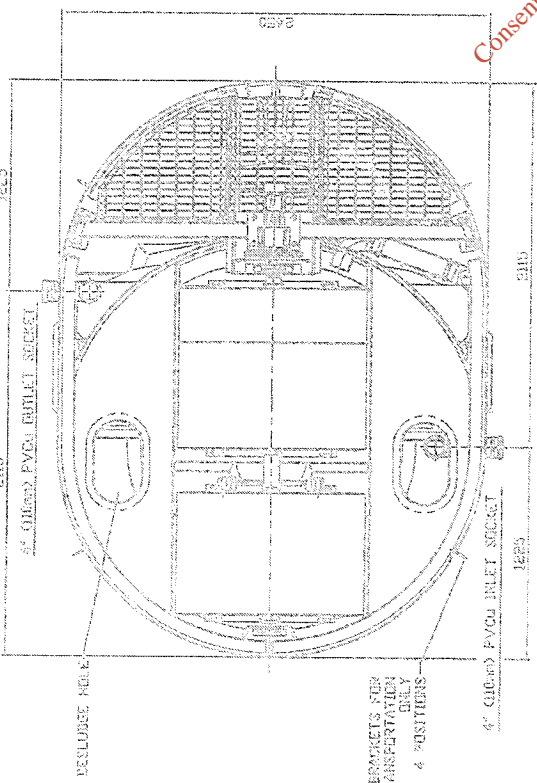

NOTES:-

1. BIDDISC TANK & COVER ARE MANUFACTURED IN GLASS REINFORCED PLASTIC (GRP), COVER IS FINISHED IN GREEN TO BS 4638 TEST 12/265
2. ELECTRICAL SUPPLY- 240 VOLTS, 2 ACPS, SINGLE PHASE (THREE PHASE OPTION), CONTROL PANEL SUPPLIED.
3. MOTOR POWER < SINGLE PHASE = 75 WATTS / FLC = 11 AMPS > < THREE PHASE = 60 WATTS / FLC = 0.95 AMPS >
4. BIDDISC MUST ONLY BE LIFTED USING WEAVING SLINGS OF A SUITABLE SPECIFICATION, AT THE LIFTING POINTS PROVIDED.
5. FOR INSTALLATION, OPERATION, MAINTENANCE & RESIDUE DETAILS REFER TO PROCEDURE SPECIFICATION, AT THE LIFTING POINTS PROVIDED.
6. 600 INLET INVERT UNIT OPTION SHOWN. 800 INLET INVERT / 1185 INLET INVERT OPTION AVAILABLE.
7. THIS DRAWING IS ALSO AVAILABLE ON OUR WEBSITE www.kingspan.com

SLING POINTS MUST BE USED FOR LIFTING

FOR LIFTING

LOCKABLE HINGED COVER, CENTRE HINGED - ONE OVER OTHER

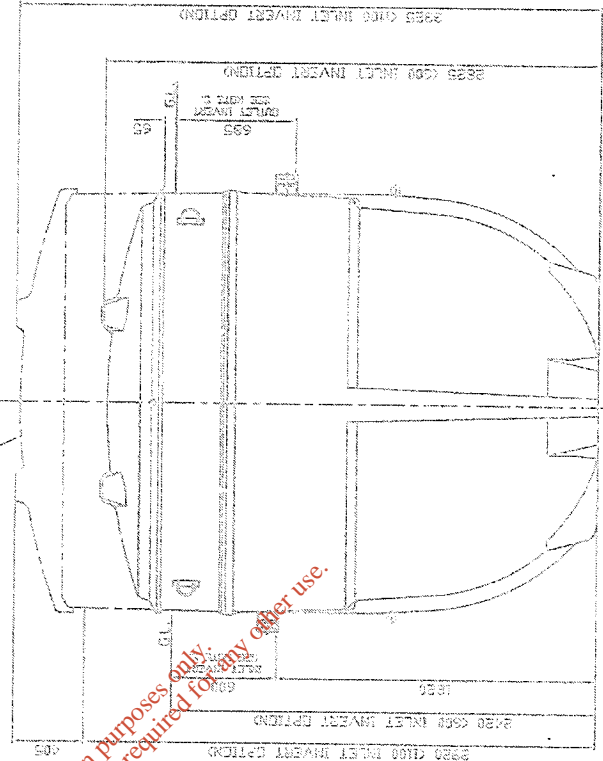

For inspection purposes only. Consent of copyright owner required for any other use.

ITEM NO.	DESCRIPTION	QTY	UNIT
1	COVER FOR SETTING PANS & WEIGHTS	1	PC
2	WEIGHTS	100	KG
3	SLINGS	1000	PCS

DD/BE BIDDISC
GENERAL
DIMENSIONS
CUSTOMER DRG

DATE: 14/5
DRAWN BY: AJ

PROJECT: DS0468P

7.0 Ancillary Equipment

Ancillary items should be installed in accordance with the Installation Guide supplied e.g.

Crude Sewage Pump Station, Effluent Pump Station, Effluent Sample Chamber, Grease trap.

8.0 Start Up

- 8.1. Refer to the Owners Handbook for details of the Start Up Procedure. We recommend that the unit is commissioned using an approved engineer.
- 8.2. Once the unit has been installed it should be left filled with water. Please switch on the motor, following the procedure in the Owners Handbook and leave the unit running, even if there is no aewage being fed into the plant. If the unit has been installed with no operational power supply, then remove the motor/gearbox unit and drive belt/chain and store in a dry or heated environment until such time as the unit is ready for permanent operation.

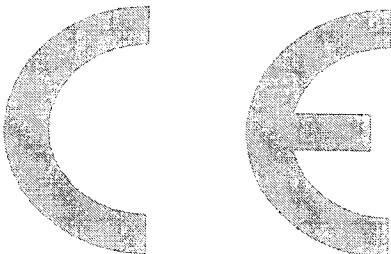
	
<p>ETS Ltd Trading as: Kingspan Environmental College Road, North Aston Clinton Aylesbury Buckinghamshire HP22 5EW United Kingdom</p>	
07	
EN 12586-3	
BA - 3F BioDisc	
Hydraulic daily load:	1.2m ³ /day - 10m ³ /day
Material:	GRP Glass Reinforced Plastic
Watertightness (water test):	Pass
Structural Calculation:	Pass
Treatment efficiency:	COD: 89%
	BODs: 96%
	SS: 95%
	Total P: 48%
	NH ₄ : 89%
	Total N: 48%
Electrical consumption:	1.3 kWh/d - 3.1 kWh/d
Sludge production:	0.21 litres per person per day

For inspection purposes only
 Consent of copyright holder required for any other use.

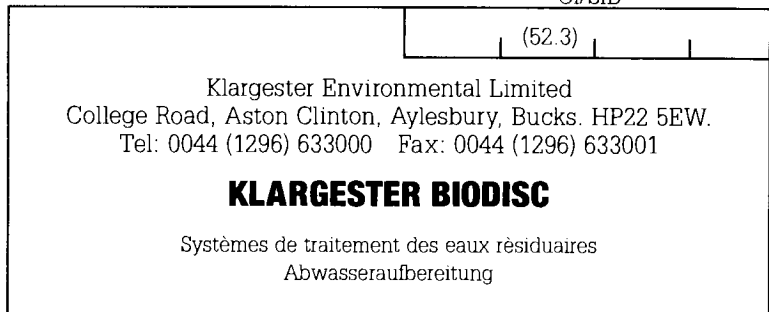

The Irish Agrément Board is designated by Government to issue European Technical Approvals. Irish Agrément Board Certificates establish proof that the certified products are **'proper materials'** suitable for their intended use under Irish site conditions, and in accordance with the **Building Regulations 1997 to 2000**.

The Irish Agrément Board operates in association with the **National Standards Authority of Ireland (NSAI)** as the National Member of UEAtc.

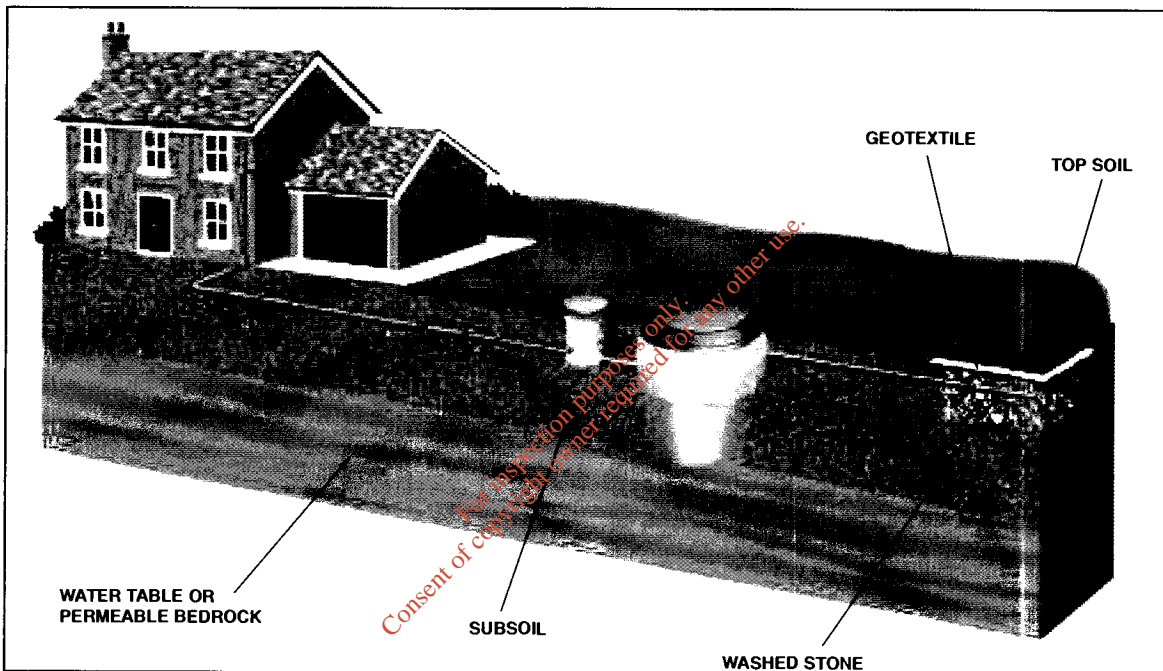

PRODUCT DESCRIPTION:

This Certificate relates to Klargester BioDisc (Confirmation of Certificate No.86/1700, Detail Sheet No 6 issued by the British Board of Agrément, PO Box No. 195, Bucknalls Lane, Garston, Watford, Herts WD2 7NG. UK).

USE

The product is for use in sewage treatment systems and for sewage collection systems designed in accordance with BS 6297: 1983 *Code of practice for design and*

installation of small sewage treatment works and cesspools. The unit is used for the retention and treatment of domestic wastewater, and the settlement of humus solids in suspension, prior to discharge of the treated effluent.

MANUFACTURE AND MARKETING

The product is manufactured and marketed by Klargester Environmental Limited, College Road, Aston Clinton, Aylesbury, Bucks. HP22 5EW.

PART 1 CERTIFICATION

1.1 ASSESSMENT

In the opinion of the Irish Agrément Board (IAB), the Klargester BioDisc is satisfactory for the purpose defined above, and meets the requirements of the Building Regulations 1997 to 2000 as indicated in Section 1.2 of this Certificate.

1.2 BUILDING REGULATIONS 1997 TO 2000

Requirement: D & H

D1 & D3 – MATERIALS AND WORKMANSHIP.

D3 – The Klargester BioDisc as certified in this Irish Agrément Board Certificate, is comprised of "proper materials" and is fit for its intended use (see Part 4 of this certificate).

D1 – The Klargester BioDisc used in accordance with this Irish Agrément Board Certificate, meets the requirements for materials and workmanship.

PART H – DRAINAGE AND WASTE DISPOSAL

H1 Drainage systems:

The Klargester BioDisc is easily installed and incorporated into soil percolation to meet Building Regulation requirements.

H2 Septic tanks

The Klargester BioDisc has been designed for use in wastewater treatment systems, for the collection and treatment of domestic wastewater when installed in accordance with the recommendations of BS 6297: 1983: *Code of practice for design and installation of small sewage treatment works and cesspools* and the E.P.A. *wastewater treatment manuals – Treatment Systems for Single Houses*. The quality of treated

wastewater from the Klargester BioDisc Wastewater Treatment System exceeds that of the effluent from a septic tank and will meet the building regulation requirements.

Information on the design capacity ventilation, safety and location requirements is given in this Agrément Certificate (see sections 2.4, 3.2 and 4.6 of this certificate). The Klargester Wastewater Treatment System can be used in domestic situations where septic tank systems are not acceptable, where sites do not comply with the recommendations of S.R.6. 1991 *Septic Tank Systems Recommendations for Domestic Effluent Treatment and Disposal from a single Dwelling House* and/or where septic tank systems have been known to fail.

PART 2 TECHNICAL SPECIFICATION AND CONTROL DATA

2.1 DESCRIPTION

This Certificate relates to Klargester BioDisc. The Klargester BioDisc has the plan form of a circular tank with tapering or vertical side walls blending into a semi-cylindrical base. The units are constructed from glass-fibre reinforced polyester (GRP) made of chopped strand glass fibres laminated in a polyester resin matrix. The tank is internally divided with a partition wall separating the primary and secondary settlement zones (see Fig. 1). Suspended above and within the primary settlement zone is the GRP Biozone, a semi-cylindrical GRP trough in which the Rotating Biological Contactor (RBC) is housed and rotates. The RBC consists of a hollow rolled section steel shaft with welded stub ends. A rolled steel section framework is built onto the shaft and supports the polypropylene 'media' (see Fig. 3). The shaft and steelwork are zinc metal sprayed or galvanized to protect against corrosion. The shaft is supported on self-aligning plastic bearings and rotated slowly by a motor and gearbox using a reinforced rubber belt and pulley. The Biozone is assembled and supported within the main GRP casing. The RBC is divided using baffles attached to the 'media packs' or fixed in the Biozone. The BioDisc unit and all internal mechanical and electrical systems are protected by a GRP cover.

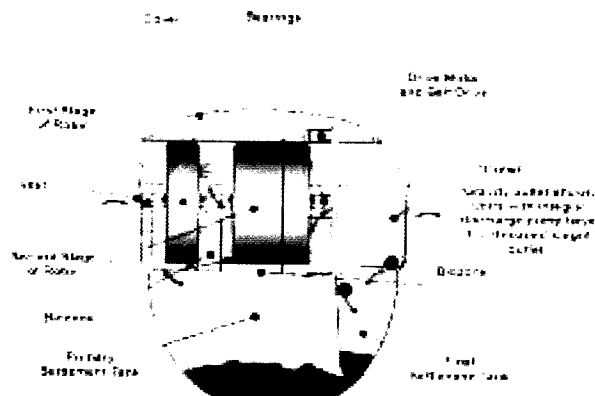

Fig. 1

The inlet and outlet sockets are 110mm diameter PVC-U kitemarked to BS EN 1401-1: 1998 (incl. AMD 9132) *Unplasticised PVC underground drain pipes and fittings*. Each socket incorporates a captive rubber ring to BS 2494: 1997 *Specification for elastomeric seals for joints in pipework and pipelines* and IS EN 681-1: 1996. The sockets are designed to accept PVC-U pipe spigots but

connection to other systems, (eg. vitrified clayware to BS 65: 1991 (1997) *Specification for vitrified clay pipes, fittings and ducts*) or to IS EN 295-1: 1991 (*Vitrified clay pipes and fittings and pipe joints for drains and sewers*) can be made by means of a short length of uPVC pipe to BS 4660: 1989 (1998) (incl. AMD 9132) and appropriate adaptors. BioDiscs which include an integral pump well, will have a 32mm spigot outlet.

Crude sewage passes through the inlet into the primary settlement zone, where the breakdown and storage of solids takes place. The heavier particles sink and settle to form primary sludge and the lighter particles remain in suspension or form a scum on the surface. Both the sludge and scum will begin to break down under the action of bacteria and other organisms. The partly clarified sewage passes through a submerged baffle into the first compartment of the Biozone. The primary sludge and scum are drawn-off by a suction tanker at regular intervals (see Table 1).

The RBC 'media' supports a biologically active film known as Biomass, which is alternately exposed to sewage liquor and air by the rotation of the RBC which is partially immersed in the sewage liquor. The liquor passes through the Biozone after passing through the primary settlement zone (see Fig. 1). Excess biological growth falling off the media in the initial part of the Biozone can pass through the slot at the bottom of this compartment into the primary settlement zone. In the remaining stages of the Biozone, the excess biological growth is kept in suspension by the turbulence created by the rotation of the RBC. The sewage liquor passing through the Biozone is progressively biologically oxidized reducing the organic material content. The resulting purified sewage passes into the final settlement zone, where the excess biological growth (humus solids) either settles or forms floating scum. Sludge from the secondary settlement zone is drawn off at the same intervals as the primary sludge (see Table 1). A facility to return the humus sludge to the primary tank can be provided as an optional extra to the system. If this option is incorporated, sludge removal from the primary tank only will be necessary. Otherwise scum removal from both primary and final settlement tanks should be carried out.

2.2 MANUFACTURE

The main tank is manufactured by spraying from cold setting polyester resin reinforced glass fibres. The cover, Biozone and baffles are made in a similar way. The RBC

'media' is vacuum formed from polypropylene copolymer sheets.

The motor and gearbox are fixed to a galvanized steel bracket which is galvanized to BS EN ISO 1461 (March 1999) *Specification for hot-dip galvanized coatings on iron and steel articles*.

PRODUCT RANGE

The tanks are designed to collect the wastewater and sewage from dwellings having the populations shown in Table 1.

Table 1: BA and BB BioDisc — basic information

Unit size	BA			BB		
Population equivalent	6 (single household)			12 (2 households)		
Media area (m ²)	72.5			97.5		
Diameter (mm)	1995			1995		
	shallow	standard	deep	shallow	standard	deep
Inlet invert depth (mm)	450	750	1250	450	750	1250
Outlet invert depth (mm)	520	820	1320	520	820	1320
Height to rim of cover (mm)	1945	2245	2745	1945	2245	2745
Overall height (mm)	2160	2460	2960	2160	2460	2960
Empty weight (tonnes)	0.31	0.325	0.38	0.335	0.35	0.405
Desludge period (approx)	12 months			6 months		
Desludge volume (m ³)	2.6			2.65		
Drive rating 1 phase/ 3 phase (kW)	0.06			0.06		
Approx. daily power consumption (kWh/day)	1.6			1.9		

QUALITY CONTROL

Quality control includes laminate thickness checks on GRP components, plating thickness of zinc and galvanised components and the checking of bought-in components against specification. Each completed unit is checked and test-run for one hour to ensure that it is mechanically sound.

2.3 DELIVERY, STORAGE AND MARKING

The BA and BB BioDisc units are completed ready for delivery at the manufacturer's works. The BioDisc units must be lifted using webbing slings of a suitable specification which must be attached to all the designated lifting points. Lifting equipment should be selected by taking into account the unit weight dimensions and the distance of lift required on site (see Table 1).

The product bears the marketing company's name, labels denoting the inlet and outlet, a list of all the items supplied, installation and operating instructions, the product specification code, serial number and the inspection date. An external label indicates the IAB identification mark incorporating the certificate number.

2.4 INSTALLATION PROCEDURE

2.4.1 GENERAL

Klargester Environmental Ltd. can advise clients of the installation requirements. Full installation instructions are provided with the equipment. A network of certified installers are available and offer a full installation service.

Electrical connections to the BioDisc unit from the main supplyboard in the dwelling must be carried out by a competent person using material suitable for the purpose.

Electrical connections must be in strict accordance with the manufacturers instructions and must comply with 'The National Rules For Electrical Installations' (ETCI), published by the 'Electro-Technical Council of Ireland' (Document No. ET101 2000).

Cables must be protected from accidental damage by a suitable conduit or other means of protection. The electrical control panel and housing must be sited adjacent to the unit for accessibility but not so close that the panel and BioDisc can be touched simultaneously. The panel must be protected from accidental damage by vehicles.

The BioDisc unit must not be installed in areas liable to localised flooding without adequate protection as specified by the manufacturers.

It is essential to take precautions to prevent damage by site traffic. Superimposed loads from vehicles etc. should not be permitted within a distance equal to the depth of excavation, unless suitable structural protection is provided. A suitable fence may be required to prevent vehicles from approaching too close to the unit.

BioDisc units are installed partly buried so that the rim of the cover is approximately 95mm above ground level. The excavation must be large enough for easy placement of the unit, permit subsequent backfilling and to allow timbering and sheeting as required to meet The Safety, Health and Welfare at Work Act, 1989. (See Fig. 2).

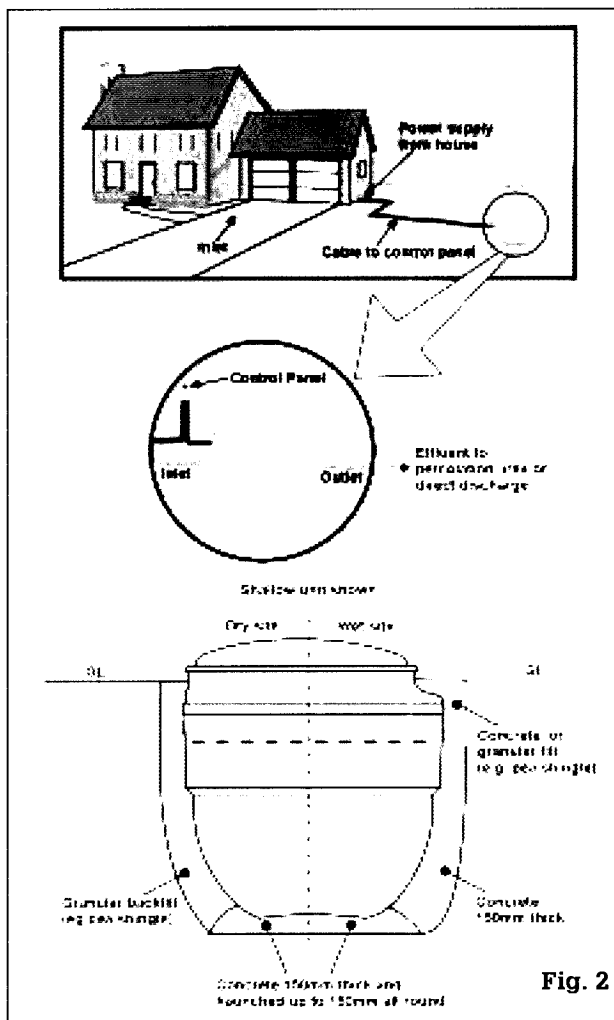

Fig. 2

The units are bedded onto concrete which is haunched up around the base of the unit. The concrete must be of sufficient thickness (minimum 150mm) and grade 25N to ensure that the unit is adequately supported with due regard to sub-soil conditions and loads imposed by the BioDisc when full. (Care must be taken to eliminate voids.) The top flange must be level to within 5mm. In freely draining ground the unit can be backfilled with gravel. In all other circumstances the excavation should be backfilled with a minimum of 225mm thick grade 25N concrete.

The backfill must be carefully consolidated around the BioDisc unit, to ensure even transfer of ground loads and to prevent localised stress concentrations. The BioDisc unit should be ballasted with water keeping the water level just above the backfill level as it progresses.

Pipe Connections

The tank is connected to 110mm diameter PVC-U pipes as required at the inlet and outlet (or 32mm outlet). For other types of pipe such as vitrified clayware etc. suitable adaptors are used with short lengths of PVC-U pipe as necessary. A short length of pipe with flexible joints should be used adjacent to the BioDisc unit to allow for differential movement between the unit and adjacent pipe runs.

2.4.2 LOCATION.

The BioDisc unit location should be chosen so that adequate access is available for safe installation and subsequent maintenance and desludging of the unit. Desludging should be carried out by means of a desludging tanker which requires access to within 30m of the unit, without transgressing the minimum separation distance from the BioDisc unit and the effluent percolation system given in Table 2.

Table 2.

FEATURE	MINIMUM SEPARATION (m)	
	Klargester Recommendation	
	BioDisc	Irrigation Area
Dwelling served	7 ⁽¹⁾	5
Adjacent dwelling	10 ⁽¹⁾	5
Wall	3 ⁽¹⁾	3
Road	3 ⁽¹⁾	3
Site boundary	3	3
Potable water source	10	30-100 ⁽²⁾
Watercourse	3	3

- The depth of the excavation to accommodate the BioDisc must be taken into account when determining this distance. The separation distance should be such that the excavation does not undermine adjacent buildings, roads or walls. This distance should not be less than 1.5 times the excavation depth.
- This separation distance should not be less than 30 metres except in the case of very free draining soils or gravels, where a minimum distance of 40 metres should be maintained. The irrigation area should be downhill of any nearby well. Where this is not possible a separation distance of at least 100 metres must apply.
- These are minimum permissible distances. However, where the site permits, irrigation areas should be located at greater separation distances from the dwelling. Also where practical on sloping sites the irrigation area should be down slope from the dwelling.

2.4.3 TREATED WASTEWATER DISPOSAL

The BioDisc produces a fully treated wastewater which is more easily absorbed into soil strata than septic tank effluent.

Two methods are recommended for the disposal of treated wastewater:

- Sub-surface irrigation.
or
- Discharge to surface water, either directly or following a polishing filter.

The choice of disposal method will be largely determined by the percolation characteristics of the site soil, which can be quantified by various criteria, notably the "T" value resulting from a percolation test, as set out in SR6: 1991.

Treated wastewater may be discharged from the BioDisc unit either by gravity, or when site conditions demand, by pumping. BioDisc units with integral discharge pumps are available for this purpose.

Site Assessment

To determine the most appropriate method of sewage treatment/disposal a three step assessment procedure is recommended.

- Consultation and visual inspection
- Trial hole
- Percolation test (e.g. Standard "T" test)

The results of this assessment will enable the selection of the most suitable method for disposing of the final treated wastewater, having regard to soil type and percolation characteristics, water table level and other factors. The disposal method will be either to sub-surface percolation, raised percolation bed or direct to surface waters, by licence which should be obtained from the relevant local authority. Reference should also be made to the publication – *Ground Water Protection Responses for On-Site Wastewater Systems for Single Houses* published by EPA/DOELG/GSI (2001).

Table 3: Soil Types and Percolation Areas.

Soil Type	Description	Percolation Characteristics	T Values Mins/25mm	Linear metres of pipe (1 metre wide trench)	
				Up to 6 Persons	7-12 Persons
A†	Sand Gravel	Very Good	>5 <10	10	20
B	Sandy Loam. Loam. Clay Loam.	Good	>10<30	20	40
C	Silty Loam. Clay Loam.	Moderate	>30<60	60	120
D*	Sandy Clay. Silty Clay. Clay	Poor	>60	—	—

†For percolation values (T) <5 consult the manufacturer

*For percolation values (T) >60 discharge direct to surface waters or a raised percolation bed.

Sub-surface percolation

- The treated wastewater discharges, by pump or by gravity, into a network of perforated pipes laid in stone filled trenches. The objective is to spread the wastewater as evenly as possible over the required land area, thus minimising the possibility of the ground becoming over-saturated.

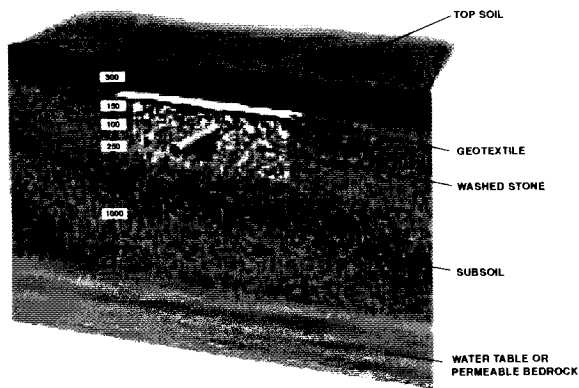

Figure 3(a): Section through effluent distribution trench (Gravity feed).

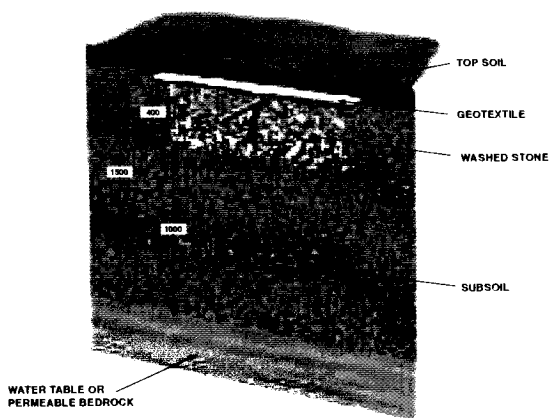

Figure 3(b): Section through effluent distribution trench (Pumped feed).

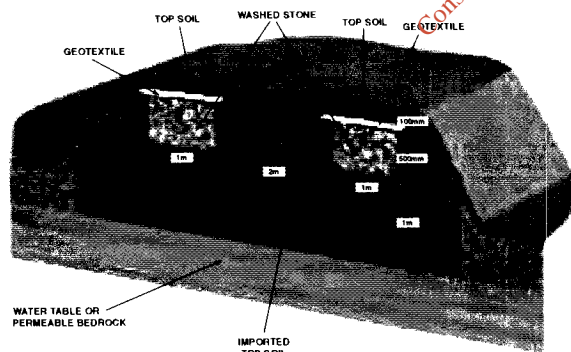

Figure 4: Section through a raised bed system used in areas of high water table.

BioDisc discharge has minimal suspended solids and is therefore, much more readily absorbed than septic tank effluent. The extent of the irrigation system may be determined by the site assessment, taking into account the soil type and percolation test results, as well as the population to be served; (see table 3). These values are given for guidance only and should be discussed in detail with the site surveyor.

The percolation area will be equivalent to the linear pipe length shown above (assuming 1 metre wide trenches).

For pumped discharges the perforated pipe is 32mm diameter (see figure 3b). For gravity discharges the perforated pipe is 100mm diameter (see Figure 3a). Trenches are generally 300-1000mm wide with the pipes laid on 250mm of clean 15-25mm stone and covered with a polythene or geo-textile soil barrier. Layout of the trenches will be determined by site topography; the overall fall of the pipes should be not more than 1 in 200. The pipes should be at least 1 metre above the highest water table level or fissured rock strata.

- b) Where the irrigation pipes have to be above existing ground level, e.g. thin topsoils and/or rock or water table close to the surface, a banked-up irrigation system may be suitable. It is generally similar to sub-surface percolation. See Figure 4.
- c) For situations where the percolation area is at a higher level, BioDisc is available with an integral discharge pump. Separate effluent pump sets are also available if necessary.

Discharge to a watercourse

Where poor soil percolation or other factors make a sub-surface irrigation system impractical, discharge to a watercourse may be considered. This will require a licence from the relevant local authority, setting the minimum acceptable discharge quality. Typical detail of a discharge to a water course is shown in Figure 5. The treated wastewater is filtered through a layer of sand or topsoil before passing to the watercourse.

In some circumstances direct discharge to a water course may be permitted.

Access to all effluent percolation systems should be provided at the end of each irrigation or filter trench via a suitably constructed AJ.

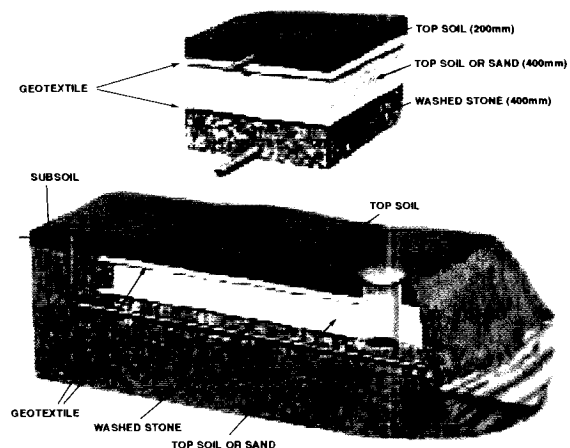

Figure 5: Section through a drainage system used to discharge to water courses.

Further treatment

In some instances (e.g. proximity to a drinking water source), the wastewater may require "polishing" before discharge to reduce coliform bacteria levels. A commonly used method is to pass the discharge through a sand filter. The BioDisc discharge is pumped to the filter using an effluent pump set capable of discharging in 180 litre doses.

Polishing filters can be partly or wholly above ground, soil covered or open. A typical filter serving a 4 person household would have a plan area of 8-20m², depending on design and type of sand used.

N.B. Disinfection systems may also be used in consultation with the manufacturer.

2.5 Commissioning:

Commissioning is an additional service which should be carried out after installation by a qualified person and this service is available from the installer or designated service provider.

PART 3 DESIGN DATA

3.1 GENERAL

The Klargester BioDisc is *suitable* for the collection and treatment of domestic sewage and should be installed in accordance with the manufacturer's instructions and to conform with the recommendations of BS 6297: 1983 *Code of practice for the design installation of small sewage treatment works and cesspools*. It is important that the loadings are based on the maximum population to be served.

BioDisc units should be sited in accordance with the relevant Building Regulations.

Ground water and flood levels should always be below plant outlet level, unless specific arrangements have been made to overcome this problem.

The discharge of the unit must be to a suitable sub-soil irrigation system or water course to the requirements of the relevant local authority.

The effluent resulting from the sewage treated by the BioDisc unit will normally be within Royal Commission Standard (ie suspended solids content less than 30 mg per litre and Biochemical Oxygen Demand (BOD) less than 20 mg per litre) provided that the hydraulic and BOD loadings are within the limits recommended by the manufacturer for the unit installed (200 litres per head per day and 60 grammes per head per day, respectively). Under certain unusual conditions the resulting effluent may not be within Royal Commission Standards. This is normal for any biological sewage treatment process, and can be caused by unusual hydraulic or BOD loading, weather conditions, contamination by grease, or

poisoning of microbiological fauna or flora by chemicals.

3.2 Design Basis

The sizes and relevant dimensions of BioDisc units certified are shown in Table 1.

The units can be fitted with a warning device which activates an alarm when the RBC has ceased rotation for any reason other than a mains power supply failure.

3.2.1 WASTEWATER QUALITY

Table 4: Treated wastewater characteristics:

	Standard	Optional*
pH		6-9
Biochemical oxygen demand	< 20 mg/l	
Suspended Solids	< 30 mg/l	
Ammonia	< 20 mg/l	< 5 mg/l
Nitrate		< 5 mg/l
Total Phosphorus		< 1 mg/l
E. coli (by soil treatment or disinfection)		

*As an option units are available to meet these performance levels for ammonia, nitrate and total phosphorus - details on request from the manufacturer.

The BioDisc can be used to provide temporary sewage treatment facilities. A short period of acclimatisation must be allowed after commissioning of the unit before a full degree of treatment can be expected. This period is generally a few weeks and is normal for any biological treatment plant.

PART 4 TECHNICAL INVESTIGATIONS

4.1 ENVIRONMENTAL ASSESSMENT

The treated wastewater from a number of working installations has been comprehensively monitored for 12 months. The test results show that values stated for the parameters listed in Table 4 are consistently achievable over a range of operating conditions.

4.2 STRENGTH

The manufacturer's design has been assessed as satisfactory. The BioDisc has adequate resistance to resist damage from minor impacts during handling but it must be slung and supported at the points recommended and marked by the manufacturer. The BioDisc has sufficient structural strength to resist soil loads in non-cohesive dry soils, but it is recommended

that BioDisc units are backfilled with dense mass concrete to resist upthrust due to buoyancy in high water table sites.

BioDisc covers are not suitable for walking on. Where necessary the unit should be fenced off or otherwise protected.

4.3 LIQUID WATER PENETRATION

The BioDisc with its pipe connections, when correctly installed has been assessed as fully capable of preventing seepage either into or from the surrounding soil. The pipe joints, when correctly made, will be watertight.

4.4 DURABILITY

The structural properties of the GRP from which the tank is constructed, in common with all similar materials, will deteriorate with time. This deterioration is accelerated by contact with ground water, sewage and dissolved or suspended organic or inorganic compounds. The resulting loss of strength or stiffness has been taken into account in the manufacturer's design code. The GRP components should remain serviceable for at least 30 years. Protected steel components may require further protection by painting, but this should not be required for at least 15 years. The mechanical and electrical components are liable to wear during operation, but the design layout is such that they can be replaced as required.

4.5 CLEANING AND MAINTENANCE

Cleaning and maintenance should be carried out in accordance with the *Operation and Maintenance Instructions* supplied by Klargest Environmental Ltd.

Summary of maintenance instructions

The BioDisc is desludged by a suction tanker. Care must be taken to avoid damage by the hose nozzle. Both the primary and secondary settlement zones must be desludged in accordance with the manufacturer's recommendations for the particular size of BioDisc. (See Table 1).

Local damage to GRP components can be repaired by the manufacturer or a suitably experienced person using standard GRP repair techniques. Any repairs must be carried out in dry conditions, and the GRP laminate to be repaired, must be thoroughly cleaned, dried, highly abraded and prepared with a suitable bonding agent.

Regular maintenance generally involves a visual examination of the Biozone, removal of the debris, cleaning the weir and checks on the belt transmission.

Rust spots on steelwork should be wire brushed and coated with a zinc based paint.

Flooding

Repair or replacement may be required should the mechanical and electrical components be subject to damage in the event of flooding.

4.6 SAFETY

4.6.1 SAFETY OF PERSONNEL

The tank cover is securely fixed to prevent unauthorised access. The cover must not be left off an unattended tank. The manufacturers provide a locking device to the cover to ensure that they can not be removed without keys. Tanks are potentially dangerous, particularly when being desludged. Desludging must never be carried out alone. Tank entry should not be attempted except by trained personnel. Naked flames which can cause explosions must not be used in the vicinity of the tanks.

The BioDisc should be positioned, or marked, or protected, to prevent superimposed loading or accidental impact by vehicles.

4.7 TESTS AND ASSESSMENTS WERE CARRIED OUT TO DETERMINE

Tests were carried out to determine:

- Resin/glass ratio Based on BS 4994: 1987
- Barcol hardness, based on BS 4549: Part 1: 1997
- Cross breaking strength by water boil, based on methods in BS 3532: 1990 (1995) Appendix C and BS 2782: Method 335 A: 1993.
- Degree of cure, by the Coggeshall test.
- Water soak test based on BS 2782: Part 4: Method 430A: 1983.
- The durability of the GRP on prolonged exposure to water was assessed by exposing samples to boiling water for 1000 hours and then measuring any loss in cross breaking strength, bending stiffness or ductility.
- Watertightness.
- Strength of cover and frame assemblies.
- Hydrostatic testing of complete tanks was carried out to check the validity of the manufacturer's design, with respect to buckling and fracture of the tank, when subjected to external pressure.
- Resistance of units to hydrostatic and ground pressure.
- Resistance to flotation
- Environmental performance

4.8 OTHER INVESTIGATIONS

- (i) Existing data on the history of use of previous installations.
- (ii) The manufacturing process was examined including the methods adopted for quality control, and details were obtained of the quality and composition of the materials used.
- (iii) An examination of the results of sample analyses of effluent from BioDisc units to measure suspended solids content and Biochemical Oxygen Demand was undertaken.
- (iv) An assessment of the tank was made in relation to degradation of mechanical properties arising from exposure to sewage, ground water, dissolved salts, dilute acids or alkalis and long-term loading conditions.

Structural steel components;

Specification and durability of the corrosion protection process.

Bought in components

- (v) Suitability for use.
 - Site visits were conducted to assess the practicability of installation.
 - A user survey and visits to established sites were conducted to evaluate performance in use.
 - No failures of the product in use have been reported to the IAB.

5.1 CONDITIONS OF CERTIFICATION

The National Standards Authority of Ireland ("NSAI") following consultation with the Irish Agrément Board ("IAB") has assessed the performance and method of installation of the product/process and the quality of the materials used in its manufacture and certifies the product/process to be fit for the use for which it is certified provided that it is manufactured, installed, used and maintained in accordance with the descriptions and specifications set out in this certificate and in accordance with the manufacturer's instructions and usual trade practice. This certificate shall remain valid so long as:

- (a) the specification of the product is unchanged;
- (b) the Building Regulations, 1997 to 2000 and any other regulation or standard applicable to the product/process, its use or installation remain unchanged;
- (c) the product continues to be assessed for the quality of its manufacture and marking by NSAI;
- (d) no new information becomes available, which in the opinion of the NSAI would preclude the granting of the certificate;
- (e) the product or process continues to be manufactured, installed, used and maintained in accordance with the description, specifications and safety recommendations set out in this certificate.

5.2 The IAB mark and certification number may only be used on or in relation to products/processes in respect of which a valid certificate exists. If the certificate becomes invalid, the certificate holder must not use the IAB mark and certification number and must remove them from products already marked.

5.3 In granting this certificate, the NSAI makes no representation as to:

- (a) the presence or absence of patent rights subsisting in the product/process; or
- (b) the legal right of the certificate holder to market, install or maintain the product/process; or
- (c) whether individual products have been manufactured or installed by the certificate holder in accordance with the descriptions and specifications set out in this certificate.

5.4 This certificate does not comprise installation instructions and does not replace the manufacturer's directions or any professional or trade advice relating to use and installation which may be appropriate.

5.5 Any recommendations contained in this certificate relating to the safe use of the certified product or process are preconditions to the validity of the certificate. However, the NSAI does not certify that the manufacture or installation of the certified product or process in accordance with the descriptions and specifications set out in this certificate will satisfy the requirements of the Safety, Health and Welfare at Work Act, 1989 or of any other current or future statute or current or future common law duty of care owed by the manufacturer or by the certificate holder.

5.6 The NSAI is not responsible to any person or body for loss or damage, including personal injury, arising as a direct or indirect result of the use of this product or process.

5.7 Where reference is made in this certificate to any Act of the Oireachtas, regulation made thereunder, statutory instrument, code of practice, national standards, manufacturer's instructions or similar publication, it shall be construed as reference to such publication in the form in which it is in force at the date of this certification.

THE IRISH AGRÉMENT BOARD

This Certificate No. 01/0094 is accordingly granted to Klargester Environmental on behalf of the Irish Agrément Board.

Date of Issue: July 1997

Signed:



Chief Executive, NSAI

Readers may check that the status of this Certificate has not changed by contacting the Irish Agrément Board, NSAI, Glasnevin, Dublin 9, Ireland.

Telephone: (01) 8073800.

Telefax: (01) 8073842.

Re-Printed November 2001



BUILDING PRODUCT CERTIFICATION

**Irish Agrément Board,
NSAI,
Glasnevin,
Dublin 9,
Ireland.**

Telephone: (01) 8073800.

Telefax: (01) 8073842.

Environmental

Certified up to 95%
efficient to European
Performance Standards

Klargester BioDisc® BA-BD

High Performance Package Sewage Treatment Plants
for Residential Applications



BOD factor 15
Produces clear, odourless and
harmless overflow
www.BODfactor.com

For inspection purposes only.
Consent of copyright owner required for any other use.

Sustainable. Reliable. Affordable



Kingspan®

Klargester BioDisc® BA-BD from Kingspan Environmental

For domestic dwellings without access to mains drainage, the Klargester BioDisc® provides a reliable, efficient and environmentally safe solution to your sewage disposal needs.

It is ideal for locations where discharge is to sub-surface irrigation, or to a suitable watercourse where approved by the Regulator, and where a septic tank will not meet the required standards.

Certified to European Standard EN 12566 - Part 3 - Annexe B - Performance Tests

In 2005, the Klargester BioDisc® underwent 40 weeks of stringent testing to assess its treatment efficiency as part of Kingspan Environmental's commitment to meet the new European Standard for small treatment plants.

After delivering exceptionally high levels of pollution removal (95%) under varying loads and conditions, the Klargester BioDisc® was awarded its Performance Certificate.

The test report also highlighted:

- The Klargester BioDisc® operates without noise or odour
- Maintenance requirements are low with good access
- No technical or mechanical faults
- Low power consumption at 1.3kw/d approx 10-14 pence per day*
- Low sludge build up and large storage capacity

Designed for Quality, Reliability and Peace of Mind

Kingspan Environmental has pioneered the development of packaged treatment plant with many thousands of successful installations worldwide. The Klargester BioDisc® is robustly constructed from corrosion free materials, manufactured and performance tested in accordance with BS EN 12566-3 and has been awarded Irish Board of Agrément Certification (for BA, BA-10 and BB sizes only). Kingspan Environmental is an accredited company under ISO 9001:2000 quality management systems. Kingspan Environmental offer a range of alarm systems to alert the end user to mechanical failure. The installation of such, will be required under BS EN 12566-3.



Unique Design

The Klargester BioDisc® is the only packaged sewage treatment plant utilising Rotating Biological Contactor technology for small domestic applications.

This process offers inherent cost and performance benefits with a low carbon footprint.

Assured Performance

Klargester BioDisc® is a high performance package treatment plant which, in normal domestic situations, will produce effluent qualities of better than 15mg/l BOD, 25mg/l SS and 15mg/l ammonia.



Low Running Costs

Klargester BioDisc® has the lowest running and maintenance costs of any packaged treatment plant in its class.

The single home unit requires an annual de-sludge only, the motor rating is 50 watts and routine mechanical maintenance is minimal.

Low Lifetime Costs

Lowest running costs combined with the quality and durability of the equipment - particularly the drive motor which has a considerably longer service life than the pumps and blowers fitted to competitive units - all add up to a significantly lower lifetime cost for the Klargester BioDisc®.



Process Stability

The Klargester BioDisc® is recognised for its process performance. This is further enhanced by Kingspan Environmental's unique Managed Flow System, which

ensures optimum performance by smoothing peak flows and buffering biological loads over the whole working day.



Low Profile Covers

Access for service and maintenance is provided via a durable, unobtrusive cover at ground level.

* BA model BioDisc® - prices subject to local supplier.

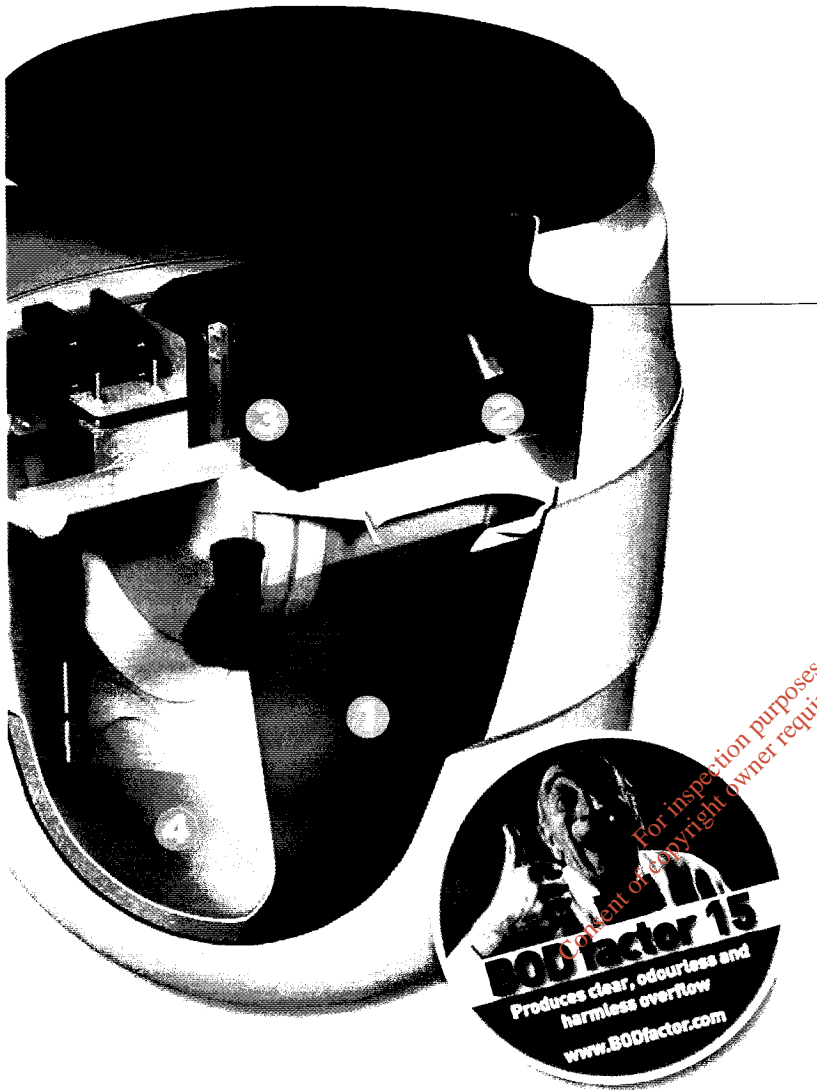

How the Klargester BioDisc® Works

Central to the operation of each Klargester BioDisc® is the Rotating Biological Contactor (RBC), which supports a biologically active film or biomass on to which aerobic micro-organisms, naturally found in sewage, become established. Natural breakdown of sewage can then occur as described below.

The Breakdown Process

Wastewater and sewage flows into the primary settlement zone ① where solids are settled out and retained. This accumulated sludge should be drawn out periodically.

Partially clarified liquor containing fine suspended solids flows upwards into the first stage Biozone ② for breaking down by micro-organisms on the RBC. Suspended solids return to the primary settlement zone and the liquor is transferred to the second stage Biozone ③ for further treatment.

Any solids remaining are settled out in the final settlement tank ④. The very high effluent quality is discharged to a watercourse.

Rotating Biological Contactor (RBC)

The RBC comprises banks of vacuum formed polypropylene media supported by a steel shaft. This is slowly rotated by a low energy consumption electric motor and drive assembly.

Note: The Klargester BioDisc® is designed to deal with normal domestic sewage. If the sewage is likely to contain unusual substances, please consult Kingspan.

Dispersal

Subject to relevant authorities consent and site conditions, the plant discharge can be a watercourse or to a drainage field.

Standard Invert Options

Three standard drain invert level options are available from stock to match the site topography and where applicable, minimise the excavation depth. The Klargester BA, BA-10 and BB BioDisc® are available with an integral pump to move effluent from point of treatment if site level demands.

Nationwide Availability

Kingspan Environmental products can be sourced from your local builders merchant or through local pollution control specialists.

Klargester BioDisc® BA-BD from Kingspan Environmental

Specification

Unit Size	Single House				
	BA	BA-10	2 houses	3 houses	4-5 houses
Population Equivalent	1 house, up to 4 bedrooms	1 house up to 7 bedrooms	2 houses up to 8 bedrooms	3 houses up to 12 bedrooms	4-5 houses 15-16 bedrooms
Overall Diameter / Width (A) mm	1995	1995	1995	2450	2450
Overall Length (B) mm	-	-	-	-	3340
Standard Drain Invert Inlet (C) mm	750*	750*	750*	600†	600†
Standard Outlet (D) mm	835	835	835	685	685
Depth from Invert to Base (E) mm	1400	1400	1400	1820	1820
Pipework Diameter (mm)	110	110	110	110	110
Sludge Storage Period (approx)	12 months	9 months	6 months	7 months	6 months
Standard Power Supply	Single phase	Single phase	Single phase	Single phase	Single phase
Motor Rating	50W	50W	50W	75W	75W
Weight (tonnes) standard units	0.388	0.418	0.418	0.650	1.100

Applications which include waste disposal units will require special sizing. Please consult Kingspan Environmental.

* Optional invert depths of 450mm and 1250mm are available. † Optional invert depth of 1100mm is available.

** Optional integral pump available in BA, BA-10 and BB models

BioDisc® BA, BA-X, BB and BC

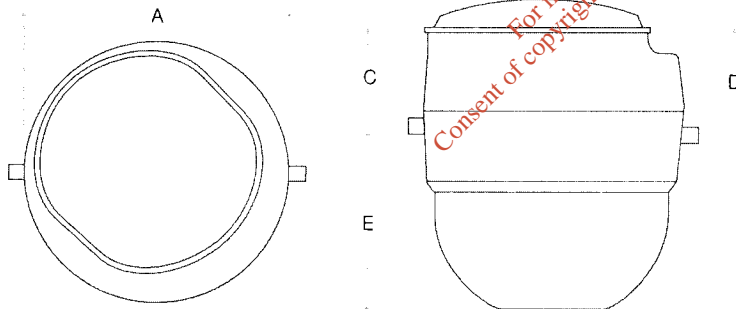

BioDisc® BD

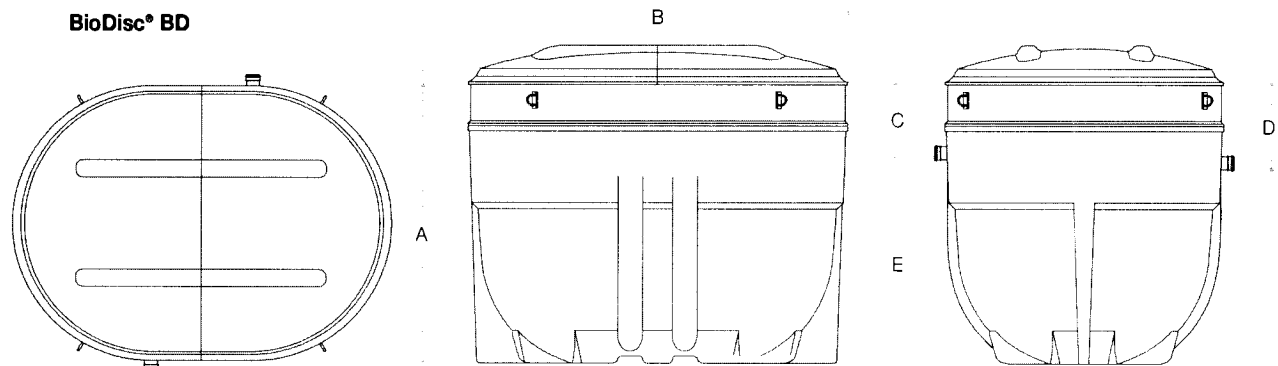

Sizing Your Treatment Plant

The above table is a general guide to selecting the correct Klargester BioDisc® for your property but, with many variables to consider, it is essential to obtain an accurate assessment.

We are pleased to offer professional advice by adhering to British Water's sizing criteria published in their guidance booklet 'Flows and Loads'.

By following this best-practice, Kingspan Environmental will ensure you are installing the most suitable Klargester BioDisc® model to serve your needs.