

**WATERFORD CORPORATION**  
**WATERFORD MAIN DRAINAGE SCHEME**

**PROPOSED WASTEWATER TREATMENT PLANT**  
**AT**  
**SPRINGFIELD HOUSE, GORTEENS, CO. KILKENNY**  
**AND ASSOCIATED WORKS**  
**ENVIRONMENTAL IMPACT STATEMENT**

*For inspection purposes only.  
Consent of copyright owner required for any other use.*

**WATERFORD CORPORATION**  
**CITY HALL**  
**WATERFORD**

**CONSULTING ENGINEERS:**  
**E.G. PETTIT & CO.**  
**SPRINGVILLE HOUSE**  
**BLACKROCK ROAD**  
**CORK**  
**JOB NUMBER; A3486**

**NOVEMBER 1998**

**REVISION CONTROL TABLE****User Is Responsible For Checking The Revision Status Of This Document**

Rev. Nr	Description of Changes	Prepared by	Checked by	Approved by	Date
A	Issued for Planning	SMcN	<del>SMcN</del>	GOS	Nov. '98

For inspection purposes only.  
 Consent of copyright owner required for any other use.

## Table of Contents

<u>Section</u>	<u>Title</u>	<u>Page</u>
	Non Technical Summary	1 of 21
 <b>ENVIRONMENTAL IMPACT STATEMENT</b>		
1.0	PURPOSE .....	1
1.1	List Of Specialist Contributors .....	2
1.2	List Of Consultative Bodies .....	2
2.0	INTRODUCTION .....	4
2.1	Alternatives Examined .....	4
2.1.2	Alternative Wastewater Treatment Plant Locations .....	10
2.1.3	Alternative Treatment Processes .....	19
2.1.4	Alternative Outfall Locations .....	25
2.2	Characteristics of the Development.....	26
2.2.1	Waterford Main Drainage Scheme.....	26
2.2.2	Site Location .....	26
	Figure 2.2.1.1 .....	27
	Fig. Nr. 2.2.2.1.....	28
2.2.3	Site Layout .....	29
2.2.4	Description of the Design .....	35
2.2.5	Construction .....	42
2.2.6	Commissioning.....	42
2.2.7	Operation.....	42
2.2.8	Associated Development Works .....	44
2.2.9	Power and Water Supply .....	48
3.0	GENERAL .....	50
3.1	Human Environment.....	50
3.1.1	Employment And Economic Activity .....	50
3.1.2	Population and Housing.....	51
3.1.3	Land-use.....	52
3.1.4	Recreation .....	56
3.1.5	Transportation .....	56
3.2	Flora and Fauna .....	57
3.2.1	Terrestrial Environment.....	58
3.2.2	Estuarine Environment .....	60
3.3	Natural Heritage Areas .....	61
3.4	Geology and Soils.....	62
3.4.1	Geology .....	62
3.4.2	Soils .....	63
3.5	Hydrology and Water Quality.....	63
3.6	Climate and Air Quality .....	70
3.6.1	Climate.....	70
3.6.2	Winds .....	70
3.6.3	Air Temperature .....	70
3.6.4	Air Quality/Baseline Assessment.....	71
3.7	Noise .....	71

3.8	Landscape .....	77
3.8.1	Topography .....	77
3.8.2	Visual Resources .....	77
3.9	Cultural Heritage .....	79
3.10	Material Assets .....	82
3.10.1	Sustainable Development .....	82
3.10.2	Severance .....	83
4.0	ENVIRONMENTAL IMPACTS .....	84
4.1	Human Environment.....	84
4.1.1	Employment and Economic Activity .....	84
4.1.2	Population and Housing.....	85
4.1.3	Land Use.....	85
4.1.4	Recreation .....	87
4.1.5	Transportation .....	88
4.1.6	Health and Safety.....	89
4.2	Flora and Fauna .....	90
4.2.1	Terrestrial Environment .....	90
4.2.2	Estuarine Environment .....	92
4.3	Natural Heritage Areas .....	93
4.4	Geology and Soils.....	94
4.4.1	Geology .....	94
4.4.2	Soils .....	94
4.5	Hydrology and Water Quality .....	94
4.6	Climate and Air Quality .....	97
4.6.1	Climate.....	97
4.6.2	Air Quality.....	97
4.6.3	Odours .....	98
4.7	Noise .....	99
4.8	Landscape .....	102
4.8.1	Topography .....	102
4.8.2	Aesthetic Resources .....	103
4.9	Cultural Heritage .....	110
4.10	Material Assets .....	111
4.10.1	Sustainable Development .....	111
4.10.2	Severance.....	112
4.11	InterActions .....	112
4.12	Do Nothing Scenario .....	112
5.0	GENERAL .....	114
5.1	Human Environment.....	114
5.2	Flora and Fauna .....	114
5.3	Natural Heritage Areas .....	115
5.4	Geology and Soils.....	115
5.5	Hydrology and Water Quality .....	115
5.6	Climate and Air Quality .....	115
5.7	Noise .....	116
5.8	Landscape .....	116
5.9	Cultural Resources .....	117
5.10	Material Assets .....	117

**References**

<b>Appendix A</b>	<b>Mathematical Modelling of River Suir</b>	<b>34 Pages</b>
<b>Appendix B</b>	<b>Industrial Wastewater Survey</b>	<b>5 Pages</b>
<b>Appendix C</b>	<b>Archaeological Assessment</b>	<b>8 Pages</b>
<b>Appendix D</b>	<b>Air Quality Dispersion Modelling</b>	<b>19 Pages</b>
<b>Appendix E</b>	<b>Flora and Fauna in the vicinity of the Waterford Main Drainage Scheme</b>	<b>25 Pages</b>
<b>Appendix F</b>	<b>Noise Survey</b>	<b>5 Pages</b>

*For inspection purposes only.  
Consent of copyright owner required for any other use.*

## NON TECHNICAL SUMMARY

### 1.0 INTRODUCTION

Waterford Corporation proposes to construct and operate a new urban wastewater treatment plant on a 18 ha portion of land located at Springfield House, Gorteens, County Kilkenny. Other works associated with this development include pipelines, pumping stations and an outfall pipeline. The purpose of this development is to provide Waterford City and its environs, including the portion of Kilkenny County contiguous to Waterford City known as the environs of Waterford City, with appropriate primary and secondary wastewater treatment capabilities.

An Environmental Impact Statement (EIS) is required as part of the Planning Approval Application for the proposed project. The primary objective of the EIS is to identify baseline environmental and socio-economic conditions in the project area, predict potential beneficial and/or adverse effects of the project, and develop appropriate mitigative actions where necessary.

This Non-Technical Summary provides a summary of information detailed in the EIS under the following headings:

- Project Description
- Receiving Environment
- Environmental Impacts
- Amelioration of Impacts

### 2.0 PROJECT DESCRIPTION

The Waterford Main Drainage Scheme will cater for the wastewater from the Waterford Co. Borough and its environs in County Kilkenny, including industrial discharges from these catchments.

### 2.1 ALTERNATIVES EXAMINED

This section identifies the various alternative wastewater treatment plant schemes, alternative treatment plant site locations, alternative treatment processes and alternative outfall locations that were examined for the Waterford Main Drainage Scheme. This assessment was conducted as part of the Preliminary Report for the scheme which was prepared in 1994. Alternatives were evaluated on engineering, economic, and environmental criteria.

## 2.1.1 Alternative Wastewater Treatment Schemes

An evaluation was undertaken examining the feasibility of the provision of two separate wastewater collection systems and wastewater treatment plants (one to serve areas in Waterford and its environs in South Kilkenny north of the Suir and the other to serve areas in Waterford to the south of the Suir) as opposed to one scheme which would cater for all wastewater north and south of the Suir. It was concluded that a significant cost savings would be derived from the provision of a single wastewater treatment plant to cater for wastewater from the north and the south of the River Suir. (Refer to Table 2.1.1.5).

## 2.1.2 Alternative Wastewater Treatment Plant Locations

The wastewater treatment plant which is the subject of this Environmental Impact Statement, is to be located at Springfield House, Gorteens, Co. Kilkenny.

During preparation of the Preliminary Report in 1994, nine potential sites for the location of an urban wastewater treatment plant to service Waterford City and Environs including a portion of South Kilkenny were considered. These potential sites were examined on the basis of engineering, environmental and economic considerations. A site at Gorteens Co. Kilkenny was considered to be the most favourable site based on economic and environmental considerations (Refer to Figure 2.1.2.1).

As part of the consultation process, the Preliminary Report was presented to a joint sitting of Waterford Corporation and Kilkenny County Council (Piltown area) and at a separate date to representatives of the Belview Area Resident's Association. As a result of these consultations requests were made to consider 15 alternative sites in and around the Gorteens site. The assessment revealed that a site at Springfield House offered the same economic and environmental benefits as the site identified in the 1994 Preliminary Report. Furthermore, the site provided better screening from adjacent residential properties. The site is also designated for the purposes of a wastewater treatment plant in the Belview Area Action Plan 1997 (as amended in May 1998) (Refer to Figure 2.1.2.2).

The site at Springfield House was therefore determined to be the preferred site for the wastewater treatment plant.

### 2.1.3 Alternative Treatment Processes

The 1994 Preliminary Report included an assessment of alternative wastewater treatment processes suitable for a large urban wastewater treatment plant. This assessment considered the various unit processes as follows:

- Stormwater handling and disposal.
- Preliminary treatment, including screening and grit/grease removal.
- Primary settlement.
- Secondary treatment.
- Sludge Handling and Disposal.
- Advanced Sludge Treatment.

#### Stormwater Handling and Disposal Strategy

An assessment of three separate strategies for the handling and disposal of stormwater at the treatment plant site was undertaken. It was determined that flows up to 3 DWF would be carried forward to primary settlement and the subsequent secondary treatment process whereas flows in excess of 3 DWF would be overflowed to separate stormwater settlement tanks. This storm water handling system provides the most economically and environmentally acceptable system for effective control, treatment and disposal of potentially large quantities of stormwater (Refer to Figure 2.1.3.1).

#### Preliminary Treatment

Preliminary treatment consists of screening, grit and grease removal. The alternative grit and combined grit/grease removal systems suitable for large wastewater treatment plants which were evaluated included: Spiral flow aerated grit and grease removal system, Vortex Separators and Sedimentation Tank/Constant Velocity Systems/Detritors. The aerated grit and grease removal system was determined to be the preferred option.

#### Primary Settlement

Circular settlement tanks were determined to be the preferred option to be adopted for the scheme due to the associated advantages namely fewer individual units required; more effective flow distribution; and a more efficient sludge collection.



## Secondary Treatment

The secondary treatment processes that were assessed included activated sludge and biological filtration and variations of both. The conclusions of this assessment were that the conventional (high rate) activated sludge treatment system should be adopted for the treatment of the urban wastewater from the Waterford Main Drainage Scheme.

## Sludge Treatment and Disposal

Alternative methods for sludge thickening, stabilisation, dewatering and disposal of sludge were assessed.

Options for sludge thickening included: gravity thickening, dissolved air flotation: centrifuge, gravity belt thickening, and rotary drum thickening. It was determined that primary and secondary sludge would be thickened using gravity belt thickening.

Options assessed for stabilisation of the sludge included: Mesophilic Anaerobic Digestion: Thermophilic Anaerobic Digestion: Conventional Aerobic Digestion: Thermophilic Aerobic Digestion: and Co-digestion of Sewage Sludge and the Organic Fraction of Municipal Solid Waste. Advanced sludge treatment methods were also assessed. This assessment identified Mesophilic anaerobic digestion as the most appropriate process for the Waterford Main Drainage Scheme. Pre-pasteurisation in advance of Mesophilic digestion is also to be provided to improve the quality of the sludge for handling or disposal.

Sludge dewatering is the physical (mechanical) unit operation used to reduce the moisture content of sludge. Several forms of dewatering were evaluated including Filter Belt Press, Plate Filter Press (Membrane Filter Press) and Centrifuge. It was determined that Digested primary and secondary Sludge would be dewatered using Centrifuge/high pressure belt presses.

## Sludge Disposal

Three sludge disposal options were examined: Disposal to Landfill: Landspreading: and Disposal to Forestry/Land Reclamation/Dedicated Land. The outcome of the assessment recommended that sludge should be landspread where possible and where this was not appropriate the sludge should be landfilled. It was also noted that due to the limited availability of land, landfill will be an important disposal route in the short term.

## 2.1.4 Alternative Outfall Locations

The options for a suitable treatment plant site and the options for a suitable outfall location are in some respects interdependent. Investigations into a suitable outfall location concentrated on the Gorteens area. The proposed location is in the main channel to the north-east of Little Island. This site was chosen due to the following reasons:-

- the proximity to preferred treatment plant site
- the distance from existing shellfish cultivation areas
- the distance from existing bathing areas
- the depth of the channel at this location

## 2.2 CHARACTERISTICS OF THE DEVELOPMENT

The proposed development provides for the construction of a wastewater treatment plant and associated works, to serve Waterford City and its environs.

### 2.2.1 Waterford Main Drainage Scheme

The proposed development consists principally of the construction of a wastewater treatment plant to serve Waterford City and environs. Associated works which will be carried out as part of this development include the construction of an access road, pumping station, and the laying of rising mains and gravity sewers to direct the wastewater to the new treatment plant. (Refer to Figure 2.2.1.1).

### 2.2.2 Site Location

The site for the proposed wastewater treatment plant is the Springfield House site which consists a 18 hectare parcel of land located in the townland of Gorteens, Co. Kilkenny. The proposed site is designated for the development of a wastewater treatment plant in the Kilkenny County Council, Belview Area Action Plan 1997 (as amended May, 1998) (Refer to Figure 2.2.2.1).

### 2.2.3 Site Layout

The layout of the proposed wastewater treatment plant is shown in Figure 2.2.3.1. The layout of the plant avoids any interference with the Springfield House and a buffer zone is provided to the saltmarshes to the south of the site.

The main structural elements of the site consist of screening and grit removal buildings, two covered primary settlement tanks, five rectangular aeration tanks, five final settlement tanks, a blower building, two stormwater tanks, primary sludge thickener tanks, a sludge blending tank, a sludge pasteurisation tank, two sludge digester tanks, a sludge digestion control building and administration buildings. Provision has been made in the design and layout of the plant for future nutrient removal facilities, a further three aeration tanks, a further three final settlement tanks and a third sludge digester tank.

### 2.2.3 Description of the Design

The proposed wastewater treatment plant's design will meet the effluent standard as required by the Environmental Protection Agency Act 1992 (Urban Wastewater Treatment) Regulations, 1994 (S.I. Nr. 419 of 1994). Nutrient removal (i.e., nitrogen and phosphorus) is not required as the Suir Estuary has not yet been designated as a "sensitive" area by the Department of the Environment. In the event that this should occur the design of the plant allows for retrofitting of nutrient removal facilities.

The proposed components of the wastewater treatment process are as follows:-

#### Stormwater Handling, Treatment, and Disposal

The wastewater treatment plant will provide preliminary treatment (screening and grit removal) for flows up to approximately 6 times the Dry Weather Flow (6 DWF). Flows up to 3DWF will receive primary and secondary treatment. After the preliminary treatment stage, flows in excess of 3DWF will overflow, to storm holding tanks. The contents of the storm holding tanks will be pumped back through the treatment plant at times when the inlet flow is reduced. When the capacity of the storm holding tanks is exceeded the overflow is mixed with the treated effluent prior to discharge to the receiving waters.

#### Screening.

Wastewater entering the plant will pass through screens with a bar spacing of 5mm which will remove solid materials from the wastewater as it arrives at the treatment plant. Screened materials will be washed, compacted and bagged and removed in skips for disposal to landfill.

## **Grit and Grease Systems.**

Grit and grease removal facilities are to be provided downstream of the screens. The ultimate disposal of the grit will be to landfill. Grease will discharge to the anaerobic sludge digestion process for treatment/degradation.

## **Primary Sedimentation.**

From the grit/grease removal system the wastewater flows by gravity to the two primary sedimentation tanks. The solid material which settles in the sedimentation tanks (primary sludge) will be thickened in sludge thickening tanks prior to feeding to the sludge treatment process.

## **Secondary Treatment**

Wastewater from the primary sedimentation tanks will be further treated in an activated sludge treatment process. The process essentially involves the degradation of the organic material in the wastewater using micro-organisms. The wastewater is held in the aeration tanks for sufficient time for the micro-organism to degrade the biodegradable material to meet the required effluent standard. When this is complete the treated wastewater is separated from the micro-organism in the final clarifiers and the settled biomass is returned to the aeration tanks or wasted as secondary waste activated sludge to the sludge treatment process.

## **Sludge Treatment**

The by-product of the activated sludge process is waste activated sludge. Waste activated sludge arising in the process will be thickened, blended with on-site primary sludge, pre-pasteurised (to reduce pathogens) and treated in a sludge digestion process (mesophilic digestion). The digestion process reduces the volatile organic fraction of the sludge which results in a stabilised end-product (odour-free). The treated sludge is dewatered and disposed off-site for landspreading and landfilling. Biogas, a valuable by-product of the sludge digestion process, will be burned in an on-site Combined Heat and Power (CHP) plant. Facilities will be provided for gas storage and an enclosed flare will be provided for emergency use.

### **2.2.4 Construction**

Construction is anticipated to commence in spring/ summer of 2000 and will extend over a 24 month period. The timing for the construction of the wastewater plant will depend upon the completion of other associated works. The construction works associated with this development will involve normal construction activities. Some more

specialised techniques may include piling, tunnelling and marine works. Blasting is not envisaged for this development. The Contractors' parking facilities and site accommodations associated with the construction phase will be located within the site boundary. Temporary site fencing will be erected and maintained to secure the site during the construction phase.

### 2.2.5 Commissioning

It is anticipated that the wastewater treatment plant will be commissioned immediately on completion of construction. It is expected that mechanical, electrical and process commissioning will extend for approximately 12 weeks after start-up of the plant. The full capacity of the plant may not be utilised for some years as the design capacity is to the year 2025.

### 2.2.6 Operation

The wastewater treatment plant will be operational 24 hr/day, 365 day/year. It is not anticipated that the plant will be staffed 24 hrs/day. The normal working hours will be typically 8.00am – 6.00pm Monday to Saturday.

It is anticipated that 6 full-time employees will be required to operate the wastewater treatment plant.

The plant will be substantially automated and controlled by a SCADA (Supervisory Control and Data Acquisition) system. All critical control functions will be linked to alarms with automatic dial-out facilities to alert maintenance staff.

Monitoring and sampling facilities are to be provided at the inlet and outlet of unit process to monitor plant efficiency and performance. On-site lighting will be provided for access and maintenance purposes. Continuous night time lighting will be provided on internal access roads and other locations only as required for safety reasons.

Safety measures at the wastewater treatment plant site will provide for the requirements of all plant personnel and will limit access to the site by unauthorised persons.

## 2.2.7 Associated Development Works

Other associated works which will be carried out as part of the Waterford Main Drainage Scheme include interceptor sewers, rising mains, pumping stations and gravity sewers. Certain elements of the scheme have been constructed to date and these include the Waterpark Pumping Station and Interceptor Sewers Nr. 3 & 4. Interceptor Sewer Nr. 1 is due for construction in spring 1999.

The other elements of the scheme which have yet to be constructed include:-

- Twin 700 millimetre rising mains from Waterpark Pumping Station to a header chamber at Christendom.
- Interceptor Sewer Nr. 2; Separate foul and stormwater sewers to serve existing and proposed development in land adjoining Kilbarry Road, including a pump station at Bleach Bridge.
- Sycamore/Glenville and Freshfields – the collection system will consist of three small pumping stations with associated rising mains.
- Maypark Pumping Station and Rising Main; This pumping station will be the focal point for collection of wastewater arising in the “Added Area” east of Waterpark Pumping Station.
- Gravity Sewer to Treatment Plant; A large-diameter gravity sewer will commence at the Christendom header chamber and follow a route eastwards to the Springfield House site. The route of this gravity pipeline has been carefully chosen through relatively open countryside with a view to minimising excavation, achieving adequate grades, avoiding existing developments, and minimising the number of stream crossings in the area.
- Rockshire Sewerage Scheme; Connection of the two drainage systems serving Rockshire and Rocklands will involve replacing the existing comminutor stations at Rocklands and Ferrybank with pumping installations. Rising mains will be laid from the new Ferrybank pumping station to a high-level head chamber near the school and convent at Abbey Road, and from the Rocklands station to the Christendom head chamber joining the Waterpark and Christendom rising mains.
- Additional Pumping Stations; Three additional pumping stations will be incorporated into the drainage scheme. The Christendom pumping station will be located adjacent to the existing outfall for AIBP Meats. A submersible-type installation

will connect to a 300mm rising main to be laid partly in the same trench as the Waterpark rising mains.

- The Blenheim pumping station will be located just west of Blenheim Heights in the low-lying land at the head of a small inlet of the King's Channel. From there, a 225mm rising main will pass northwards along the shoreline, coinciding with the proposed new riverside amenity walkway, to the existing tank at Powerscourt.
- The Slieverue pumping station will be located in Kilmurry just east of Gyles Quay at the existing Slieverue outfall. The short rising main from this station will connect to a header chamber on the main gravity sewer to the treatment plant.

### **Collection System**

Approximately 51% of the collection system (consisting of roughly 16,650 metres of gravity sewers and rising mains) will be constructed within public roadways. Agricultural fields and pastures, primarily on the north side of the River Suir, will be traversed by approximately 19% of the collection system. Other land uses to be traversed by the collection system include open spaces (i.e. grassy areas and gardens, 6%), industrial/commercial areas (2%), and recreation areas (< 1%).

Approximately 20% of the collection system passes through natural areas including grassy marsh (14%), woodlands (2%), and the River Suir (4%) and John's River (<1%). The Rocklands pumping station will be located adjacent to an existing commuter station site. Pumping stations at Ferrybank, Christendom, Freshfield, Glenville, Snowcream, and Bleach Bridge will be located in open, grassy areas. The Maypark, Blenheim, and Slieverue pumping stations will be located in silty foreshore areas.

## **3.0 RECEIVING ENVIRONMENT**

### **3.1 HUMAN ENVIRONMENT**

The Springfield House site is located 3 miles east of Waterford City and 500 metres west of the Belview Port. The Belview Port, one of Ireland's premier ports is currently undergoing phased development which, indirectly and directly will lead to employment creation. Development in the Belview Area is controlled by the Belview Area Action plan 1997 (as amended May 1998). The area has significant development potential given the reservation of five 'landscape compartments' for the location of strategic industry. In the Belview Action Plan the Springfield House site

(WT.9) has been designated as the proposed location for the development of a wastewater treatment plant (Refer to Figure 2.2.2.2)

The Census conducted in 1996 concluded that the population for Waterford County Borough and Waterford Suburbs was 40,328 and 1032, respectively. In order to achieve a design figure for the wastewater treatment plant, the population projections as identified in the 1989 Waterford City Development Plan were used as these figures compared well with population figures as obtained in the 1991 and 1996 Census.

In the immediate vicinity of the proposed development site scattered farmhouses and associated outbuildings are interspersed among the fields. Only one occupied residence is located within 200 metres of the site. (Refer to Figure 3.1.2.1).

The general Waterford area supports a variety of land uses including a developed urban centre, residential, industrial/commercial, recreational, agricultural, and open space areas. Immediately surrounding the wastewater treatment plant site, agricultural fields segregated by hedgerows dominate the landscape.

A variety of recreational activities take place in the Waterford area including boating, recreational fishing, sightseeing, golf, jogging/walking, field sports, and nature watching. Water-contact activities such as swimming and bathing are uncommon in the area due to poor riverine water quality and a lack of suitable beaches. There are two golf courses, Waterford Castle and Faithlegge which are located to the south of the River Suir. In the immediate vicinity of the site, recreational activities are limited to strolling, birdwatching and golfing at the private mini golf course located in the grounds of the nearby residence to the north-east of the site.

Access to the Springfield House site will be through a new road to be constructed from the Belview Port access road (N29) through five fields to the north-east of the site. The port road is linked with an existing public road that connects to the Euroroute National Primary road (N25) approximately 2.4 kilometres from the port road.

The Waterford / Rosslare railway line is located along the northern bank of the River Suir, traversing the saltmarshes to the south of the site.

### **3.2 FLORA AND FAUNA**

The Springfield House site contains the former garden area of Springfield House, now a heavily poached pasture which contains a mixture of annual and perennial weeds co-existing with native marsh plant species and small tree and shrub groupings. To the south of the



house is an old damp meadow which contains abundance of Perennial Rye grass, Rough meadow grass and Sweet Vernal grass. The site contains two impressive hedgebanks, one north-south oriented and the other east-west oriented. The boundaries of the site are densely vegetated, in particular the eastern boundary containing mature trees. The abundance of well-developed, mature, deciduous tree species / hybrids in the compact Springfield House site is of botanical interest. The old damp meadows to the north-east and the saltmarshes to the south of Springfield House site are considered to be floristically rich and very environmentally sensitive. Both these habitats are reaching rarity status in Ireland and the value of both these habitats is enhanced by the presence of some large populations of the nationally rare Hard Rush Hybrid (*Juncus x diffusus*) in the meadow and the presence of the even rarer Hybrid Sea Couch (*Elytrigia x oliveri*) in the saltmarshes.

Birds species associated with the woodland or hedgerow habitat are Wren, Robin, Blackbird and Song Thrush. A nesting Stock Dove, Swallow and Spotted Flycatcher were recorded at the ruins of Springfield House. The woodland belt running north-south along the proposed access route to the site held several bird species. A mixture of woodland, scrubland, open country and wetland bird species were recorded along the route of the proposed outfall. The presence of the Little Egret, protected under the EU Birds Directive, further enhances the value of the saltmarshes.

In general it is considered that with the exception of the woodland along the eastern boundary of the site, the habitats elsewhere on the Springfield House site are likely to be used by a low to moderate number of mammal species. The brown rat, the rabbit and fox were recorded during a survey of the site in 1998. It is possible that protected species such as woodmouse, pygmy shrew and hedgehog use these habitats.

Shellfish such as mussels, lobster, cray fish and crabs are harvested 5 kilometres downstream of the site. Migratory fish such as Salmon, Sea-trout, Twaite Shad and Sea Lamprey pass through the Estuary en-route to their freshwater spawning grounds. In terms of biotic life, species typical of soft, muddy estuarine habitats (i.e.: sandshrimp and Baltic telin and peppery furrow shell) are likely to be present in the estuarine sediments in the vicinity of Springfield House.

### 3.3 NATURAL HERITAGE AREAS (NHA)

The saltmarshes which form the northern bank of the River Suir adjacent to the development site are in the process of being designated an NHA. The area is considered an important habitat for rare plants and estuarine birds. It is classified by Dúchas as being of National Importance.

### 3.4 GEOLOGY AND SOILS

The general Waterford Area is primarily underlain by hard feldstone and feldspathic ash with lesser configurations of greenstone ash, greenstone diorite, and bala beds with limestones. There are no areas of important geological interest in the vicinity of the Springfield House site.

Soil groups in the area of the site are pre-dominantly brown earth, a well-drained loam; clay, an imperfect drained loam, and a mixed brown earth/brown podzolic, a well-drained light loam.

### 3.5 HYDROLOGY AND WATER QUALITY

There are 26 existing urban and industrial wastewater outfalls to the River Suir upstream of Cheek Point (Refer to Figure 2.2.4.1). The ability of the River to assimilate the pollution loading from these sources is finite. Continued increases in wastewater discharges will ultimately lead to a decline in water quality standards.

There has been a slight deterioration in water quality in the vicinity of Waterford City due to increases in levels of Total and Faecal Coliforms. Otherwise conditions were fairly satisfactory from Waterford to Cheekpoint. The most serious pollution is confined to John's River in Waterford City where high levels of BOD, ammonia and Faecal Coliforms and low DO levels were recorded. Sampling of sediments and mussels for trace metals and organic matter content in 1997 revealed trace metal levels below what would generally be expected in near shore sediment (Handbook of Chemistry and Physics, C.R.C., 60th Edition), apart from lead where the average result for 1997 and 1991 was over the average (20mg/kg). Organic matter content recorded in these sediment samples taken upstream of Springfield House (Smelting House station) was high.

### 3.6 CLIMATE AND AIR QUALITY

Air quality in the vicinity of the proposed project is considered to be good with low daily ambient levels of smoke and sulphur dioxide concentrations. Likewise dust deposition rates are low and typical of agricultural areas. The oil-fired power station at Great Island some 5 kilometres downstream, isolated private dwellings, and agricultural activities contribute limited air emissions in the vicinity of the site.

There are a number of sources in the vicinity of the Springfield House site which have the potential to create odours. Potential industrial sources include a meat processing plant (located west) and a piggery (2.2 km north-east). A potential agricultural source of odour nuisance in the vicinity of the site includes the spreading of slurry.

### 3.7 NOISE

Noise is considered as a level of sound greater than that of the background sound level. The Springfield House site is located in a predominantly agricultural area. A noise survey to determine the existing background noise levels was undertaken which recorded sound levels ranging from 43.9 to 50.2 decibels in the day and 37.6 to 40.7 decibels at night. These values are within the range of values typical of rural residences. However, it should be noted that the impulsive noise related to activities associated with the operation of Belview Port to the east are known to contribute to noise levels in the area.

### 3.8 LANDSCAPE

The site is located on the northern banks of the River Suir. The topography surrounding the site is of low relief gradually rising to the north. The rural aesthetic character in the vicinity of the site has been significantly altered by industrial structures, primarily the tall, bright blue container cranes associated with the adjacent Belview Port, and two very tall, white smokestacks of the ESB power station 5 kilometres downstream of Gorteens. Another notable structure in the landscape is Gorteens Castle, approximately 1.2 kilometres north of the site. The Springfield House site is bordered to the east and the west by dense vegetation which acts as visual buffer from views to the east and west of the site. The Springfield House and gardens shield the site from views to the north, however the southern boundary of the site is exposed to views from Little Island to the south. Long views to the site from the south-east are well obscured by the densely vegetated eastern boundary.

### 3.9 CULTURAL HERITAGE

The Waterford area has a long history of occupation beginning before the Christian era. Gorteens Castle, a protected structure is located north of the site. There are a number of associated estate features visible within the grounds of the Springfield House site. A covered passage, aligned north-south, is located to the east of the house. A quay is located on the river bank. Large numbers of trees and stone walls are visible within the environs of the house. There is a stand of trees located within the centre of the Springfield House site with a number of large stones located within the stand. In the field to the south of Springfield House, there are two linear ridges aligned north-south which could be archaeological or geomorphological features (Refer to Figure 3.9.1).

### 3.10 MATERIAL ASSETS

The proposed development will provide wastewater treatment facilities for Waterford City and Environs, including a portion of South Kilkenny. The availability of this asset will allow for the natural expansion of the population of the area by having in place the capacity to cater for the pollution loading generated by same. In addition, a proportion of the wastewater treatment plant capacity has been reserved for existing and future industries in Waterford City and in the Belview area. This will facilitate industrial growth in the area providing jobs and wealth to the region.

## 4.0 ENVIRONMENTAL IMPACTS

### 4.1 HUMAN ENVIRONMENT

Construction of the wastewater treatment plant at the Springfield house site represents a capital investment of £30 million. The construction of the wastewater treatment plant will have a positive short-term impact creating 200 construction jobs over a five year period. In terms of operation of the plant 6 full-time positions will be created. The provision of a wastewater treatment facility in the Belview Area will enhance industrial development in the area.

Construction of the wastewater treatment plant at the Springfield House site will result in the permanent conversion of approximately 18 hectares of actively used agricultural fields to public utility use. Given the prevalence of land under agriculture use, the diversion of approximately 16 hectares for community services purposes is not considered significant. In addition, construction of the wastewater treatment plant at the Springfield House site is consistent with other industrial development in the area.

Widely scattered residences are located in the vicinity of the site. The nearest residence is located approximately 200 metres to the north-east of the site. The presence of mature trees and hedgerows bordering the site screen the site from residences to the north, north-east and west. Recreational activities are extremely limited in the immediate vicinity of the development site. The use of the private mini golf course in the grounds of the nearby residence to the north of the site will not be significantly impacted by the proposed wastewater treatment plant. Likewise there will be no significant impact on the patrons of the two golf courses to the south of the river (Waterford Castle and Faithlegge). Any utilisation of the shoreline and mudflats for walking or birdwatching may be temporarily disrupted during construction of the plant and outfall pipe. Water-contact activities, fishing, and boating also may be temporarily

disrupted by project construction activities. However, this impact will be short-term, minor, and restricted to the immediate construction area.

Impacts to public and private transportation will be limited and will result from an increase in traffic, primarily trucks, during construction. The increase in the number of vehicles using the Belview Port access road and N25 will not be significant. During operation of the facility, it is estimated that two covered skips per day will be needed to transport screenings and sludge to a landfill and approximately six employee-operated cars will visit the site daily. Trucks delivering necessary materials also will occasionally visit the site. Shipping traffic at the port and the River Suir in general will not be affected by the proposed project. Likewise, rail traffic will not be affected by construction or operation of the facility.

In terms of health and safety, the site is located in a relatively isolated area removed from the major centres of population. Raw sewage, currently discharged from 15 outfalls upstream of the Springfield House site, will receive secondary biological treatment which can result in a 98.8% reduction in human enteric viruses common to urban wastewater (Slage & Ford, 1983). Safety measures at the wastewater treatment plant site will provide for the requirements of all plant personnel and will limit access to the site by unauthorised persons.

## 4.2

### FLORA AND FAUNA

The construction of the wastewater treatment plant will require the removal of the east-west oriented hedgerow to the south of the Springfield House site. In addition a section of the north-south oriented hedgerow in the centre of the site including some mature deciduous trees, will also be removed. This impact is not considered significant given the abundance of mature deciduous tree species at the site and in the Belview Area. Construction of the access road should not impact on the species (Hard Rush Hybrid) which is present in abundance in a relict marshy meadow to the north-east of the site.

Most of the collection system lies within roadways and other existing wayleaves and therefore, flora and fauna will be minimally impacted. The route of the pipework takes into account the sensitive saltmarshes along the northern banks of the Suir, where there is a population of the protected Meadow Barley.

The loss of vegetation at the site associated with the construction at the plant may result in short term losses in habitat for mammals and birds. Due to construction at the site it is expected that perhaps a 30% reduction of birds numbers will occur in the immediate site, however this is a short-term impact and in the long term it is likely that there will be some recovery. The proposed access road to the Springfield House site

is likely to have minimal impact on birds using the adjacent wooded belt and hedgerows. The meadow below the Springfield House is severely poached and considered of little importance to mammals.

The interface between the shoreline and wetland habitats is likely to be significantly disturbed during the construction phase and in particular the laying of the outfall pipeline. The presence of the rare Hybrid Sea Couch in the saltmarsh may be temporarily affected, however, given the abundance of the species at the site, the interference will be minimal. Otters may temporarily abandon the habitat in the short term, however, provided there is not a significant impact on freshwater bodies and wetland habitat, otters will again utilise the area.

Predicted improvements in water quality associated with the operation of a wastewater treatment plant will enhance population levels and species diversity of estuarine flora and fauna. Short term adverse impacts to the estuarine environment will occur during construction of the river crossings at Waterpark and Maypark, as well as at the outfall pipe.

A direct displacement of certain benthic species, and some localised increases in turbidity of the nearby water column due to displacement of the existing sediments will occur during the construction phase. Sediment releases are not expected to impact the shellfish beds at Cheekpoint owing to their distance from the disturbance.

### **4.3 NATURAL HERITAGE AREAS**

The site for the proposed wastewater treatment plant will not directly impact on the proposed Natural Heritage Areas in the vicinity of the Springfield House site.

### **4.4 GEOLOGY AND SOILS**

Construction of the wastewater treatment plant will necessitate grading of a majority of the preferred site. This will result in an alteration of soil profiles and soil productivity. However, any change in productivity will be negligible as the site is being converted from agricultural to industrial use. Some soil erosion resulting from removal of vegetation and alteration of soil profiles may occur on the site. Erosion is not expected to be significant given the relatively flat nature of the site. Any runoff that may occur is expected to be retained by the vegetation surrounding the site or sediment fences, which will be used as necessary.

## 4.5 HYDROLOGY & WATER QUALITY

Short term negative impacts to water quality will occur during the construction of the two river crossings and outfall pipe. Dredging and trenching of the river channel substrate will result in temporary localised increases in sedimentation in the water column. Increases in BOD and nutrient levels may also occur as a result of re-suspension of settled material. Additional potential impacts relate to accidental releases of lubricant oils or fuels from barges and equipment during construction.

Water quality simulations were used to predict long term impacts associated with the discharge of treated wastewater. Results of modelling indicated significantly lower coliform levels downstream of the proposed outfall when compared to predicted levels associated with the continued discharge of untreated wastewater. The proposed outfall pipe location in an area with good mixing characteristics and the provision of a diffuser will allow for increased dispersion and assimilation of the discharged treated wastewater which will imperceptibly impact on the local water quality.

## 4.6 CLIMATE AND AIR QUALITY

The local climate will not be impacted by the proposed development. Impacts on air quality will be short term and localised and relate to the construction phase. The operation of plant and equipment during the construction phase will give rise to exhaust emissions and fugitive dust being released. Vegetation clearing and grading of the site may also result in occasional dust emissions, especially during dry weather.

Air quality dispersion modelling was undertaken for the site in order to predict odour concentrations at the site boundary due to the proposed wastewater treatment plant. This model predicted that the odour concentrations measured as odour units per cubic metre of air (OU/m<sup>3</sup>) would be 2.5 OU/m<sup>3</sup> within the site boundary and 1.5 ou/m<sup>3</sup> at a distance of 500 metres from the site. Odour concentrations above 5.0 ou/m<sup>3</sup> is generally accepted as being the threshold at which complaints are likely. The model predicts that the odour concentrations will be well below this value and as such there should be no negative impact from the proposed development with respect to odours.

## 4.7 NOISE

Construction of the proposed wastewater treatment plant will cause temporary, localised increases in the ambient sound levels. The noise levels emitted during construction of the proposed facility will exceed the levels that currently characterise the project area. However, these will be short term impacts. There are not expected to be any increases in the background boundary day time or night time noise levels resulting from the operation of the wastewater treatment plant. All major noise sources are to be located within buildings with acoustic enclosures. Equipment manufacturers have confirmed that equipment noise can be attenuated to eliminate increases in noise levels at the boundary of the site.

## 4.8 LANDSCAPE

Aesthetically, the site will sustain a significant and long-term impact from the change from active agricultural field to wastewater treatment facility. The site is surrounded to the east and west by a buffer zone of woody vegetation which screens the site from views from these directions. Views from the north of the plant will not be significantly adversely affected as Springfield House and gardens provide a vegetation buffer to the eastern side of the boundary and additional planting will restrict views of the site from the north-west. Currently the site is exposed to views from the south and these views will be significantly adversely impacted by the presence of a wastewater treatment plant. However, landscaping measures included as part of the development, will significantly reduce this impact and the impact will be negligible once planting has matured. Only the taller structures such as the digester tanks will be visible above the treeline. By comparison, the bright blue cranes at the nearby Belview Port and the two very tall, white smokestacks of the ESB power station located approximately 5 kilometres downstream dominate the view in the immediate area and draw attention away from the site (Refer to Plates 1-5)..

Lighting fixtures will be directed in towards the site so as to reduce overspill of light at the boundaries. The presence of boundary screening and planting together with features incorporated in the design of the site lighting to minimise glare and overspill of light etc. will ensure that the impact due to site lighting will not be significant.



#### **4.9 CULTURAL HERITAGE**

Although there are no documented occurrences of any archaeologically significant items or sites on the Springfield House site, it is possible that artefacts of interest may be unearthed during the construction works. The loss of such artefacts would be a significant impact. However, the site is considered to have a low potential for such finds.

#### **4.10 MATERIAL ASSETS**

The development of a wastewater treatment facility at the Springfield House site is consistent with Kilkenny County Council development policies and also EU Directives. Overall, the proposed wastewater treatment facility at Springfield House will have positive, significant impacts on sustainable development in the greater Waterford area including south Kilkenny. In addition to allowing additional development with associated economic benefits, the improvement of water quality in the estuary, will promote a diverse and dynamic natural ecosystem capable of supporting greater numbers of harvestable fish and shellfish. This will result in direct economic and ecological benefits.

Construction and operation of the proposed development is not expected to cause significant long-term severance impacts in the site vicinity. Present activities involving the site are restricted to agriculture. Although this activity will clearly be curtailed, activities in the immediate vicinity will be unaltered.

#### **4.11 INTERACTIONS.**

It is concluded that no synergistic effects due to interaction of impacts related to the proposed development are anticipated.

#### **4.12 DO NOTHING SCENARIO**

The Do Nothing Scenario relates to *not* constructing a wastewater treatment plant. This would result in the continued discharge of raw sewage into the estuary and which would lead to the continued decline in water quality. This would have a direct negative impact on shellfish and mariculture in the Estuary. In addition, this scenario would place restrictions on future residential and industrial development in the area.

## 5.0 IMPACT AMELIORATION

The proposed development includes for a comprehensive landscaping plan and items of plant and equipment which have the potential to create an environmental nuisance are housed. The adverse impacts which have been identified are minor and can be ameliorated to some extent by employing good management practices in the operation of the plant. The following are the amelioration measures which are suggested:-

- Implement an environmental management system for the operation of the plant.
- Carry out regular maintenance of plant and equipment.
- Plant mature trees where possible as part of the landscaping plan.
- Carry out odour audits to demonstrate the predictions of the odour model.
- Carry out regular noise surveys at the boundary of the site.
- Consider installing high tanks partially below ground.

For inspecting purposes only.  
Consent of copyright owner required for any other use.

## CHAPTER 1 – INTRODUCTION

### 1.0 PURPOSE

Waterford Corporation proposes to construct a new urban wastewater treatment plant with associated collection mains and a new treated effluent outfall to provide Waterford City and its environs (including the portion of south Kilkenny County known as the Environs of Waterford) with appropriate primary and secondary wastewater treatment capabilities. Facilities will also be provided for the handling, treatment, and ultimate disposal of stormwater and sludge in compliance with the Environmental Protection Agency Act, 1992 (Urban Wastewater Treatment) Regulations, 1994 (S.I. No. 419 of 1994 ) which gave effect to European Community (EC) Directive 91/271/EEC. Articles 3 & 4 require that Sanitary Authorities provide collection systems and secondary treatment for urban wastewater.

European Communities (Environmental Impact Assessment) Regulations 1989, S.I. 349/89, gives effect to the EC Directive 85/337/EEC concerning Environmental Impact Assessment. The proposed wastewater treatment plant for Waterford City and Environs will have a total capacity of 148,500 Population Equivalent. This capacity exceeds the size threshold as outlined in the 1<sup>st</sup> Schedule of these regulations (i.e.: Wastewater Treatment Plants with a capacity greater than 10,000 population equivalent). Therefore, an Environmental Impact Statement (EIS) is required in accordance with these regulations and with Local Government (Planning and Development) Regulations 1990, S.I. 25/90.

This statement has been prepared in accordance with the requirements of the Statutory Regulations, S.I. 349/89, and European Communities (EIA) Regulations 1994, S.I. 84/94 and also in accordance with the Environmental Protection Agency publication 'Draft Guidelines On The Information To Be Contained In Environmental Impact Statements'.

The structure of the EIS is as follows:

- Non-Technical Summary (also made available as a separate document).
- Introduction
- Description of the Project
- Emissions to the Environment
- Receiving Environment
- Environmental Impacts
- Impact Amelioration

The above structure is known as the Direct Format Structure and has been adopted for this statement.

The primary objective of the EIS is to identify baseline environmental and socio-economic conditions in the project area, predict potential beneficial and/or adverse effects of the project, and develop appropriate mitigative actions where necessary.

## 1.1 LIST OF SPECIALIST CONTRIBUTORS

In addition to work performed by E.G.Pettit & Co. contributions to this statement were made by the following:

Mathematical modelling for the River Suir/Barrow/Nore Estuary - Environmental Research Unit (ERU).

Odour dispersion modelling - Envirocon Ltd.

Noise Survey - Department of Civil and Environmental Engineering, University College, Cork.

Landscaping - Brady Shipman Martin

Archaeological Survey - Eachtra Archaeological Projects.

Photo Imagery - Visual Design Studios.

## 1.2 LIST OF CONSULTATIVE BODIES

Consultation with relevant concerned bodies was undertaken as required by statutory regulations in order to ensure that all possible implications of the proposed development were addressed in the Environmental Impact Statement. A list of all authorities, associations and interested bodies consulted in relation to the proposed wastewater treatment plant at Waterford are detailed below;

Office of Public Works  
 South Eastern Health Board  
 South Eastern Regional Tourism Organisation  
 National Parks and Wildlife Service  
 Waterford Harbour Commissioners  
 The Coastal Zone Department (Department of the Marine)  
 Belview Residents Association  
 Teagasc  
 IFA  
 Central Fisheries Board

Coillte Teoranta  
Waterford Castle Golf and Country Club  
Faithlegg Golf Club

*For inspection purposes only.  
Consent of copyright owner required for any other use.*

## CHAPTER 2 – DESCRIPTION OF THE PROJECT

### 2.0 INTRODUCTION

This Chapter of the EIS provides an overview of the proposed Waterford Main Drainage Scheme. Section 2.1 addresses the alternative wastewater treatment schemes, locations, plant designs, treatment processes and options for an outfall discharge point. The characteristics of the project are outlined in Section 2.2, which provides details on the wastewater treatment plant location, layout and design. Section 2.3 provides details of construction, commissioning, operation and future expansion of the wastewater treatment plant. Section 2.4 describes other developments associated with the Waterford Main Drainage Scheme.

### 2.1 ALTERNATIVES EXAMINED

This section identifies the various alternative wastewater treatment options and potential treatment plant site locations and associated collection systems, examined for the Waterford Main Drainage Scheme. This assessment was conducted as part of the Preliminary Report for the scheme which was prepared in 1994. Alternatives were evaluated on engineering, economic, and environmental criteria. Sub-Section 2.1.1 outlines the alternative wastewater treatment schemes that were assessed. Sub-Section 2.1.2 outlines the alternative wastewater treatment plant locations that were examined. Sub-Section 2.1.3 outlines the alternative plant designs that were considered. Sub-Section 2.1.4 examines the alternative treatment processes that were assessed. Finally, Sub-Section 2.1.5 examines the alternative outfall locations.

#### 2.1.1 Alternative Wastewater Treatment Schemes

The boundary of Waterford City extends north of the River Suir to include the Ferrybank area. In establishing the most appropriate drainage scheme for the City it was concluded that there was a need to evaluate the feasibility of two separate wastewater treatment plants, one north of the river and one south of the river, versus one combined treatment plant. Furthermore, if a wastewater treatment plant is to be constructed on the northern side of the river, such a plant should be sized to cater for adjacent areas in South Kilkenny. For all of the options, potential sites were identified and evaluated.

The two alternative schemes which were identified are as follows:

### **Scheme A**

The scheme consisted of two options. All wastewater from north of the River Suir, including the Ferrybank area, combined in one treatment plant (**Plant A1**) and all wastewaters from south of the River Suir including areas outside the Waterpark catchment area combined in a second treatment plant (**Plant A2**).

The catchment on the south side of the river is divided into two sub catchments, i.e. Waterpark and “added area”. The Waterpark catchment accounts for approximately 90% of the discharge load from the south side of the River Suir. A third option of providing a separate wastewater treatment plant for the “added area” was examined. However, due to the relatively small pollution loading and its close proximity to the Waterpark catchment area the option was rejected on economic and environmental grounds.

### **Scheme B**

Scheme B consisted of a combined wastewater treatment for both Waterford City and a portion of South Kilkenny. Wastewater from areas to the north and south of the River Suir would be pumped to a combined wastewater treatment plant (**Plant B**). A wastewater treatment plant capable of handling a combined scheme could be located on either the north or south side of the River Suir, depending on the availability of suitable sites. Identification of suitable sites was initially assessed in accordance with the following criteria:

- economic implications for the collection system.
- environmental impacts.

Table 2.1.1.1 illustrates the potential sites identified for both schemes. The table indicates the design population equivalent for each option, the area of land required to service these populations and the locations which present themselves for at least preliminary considerations as sites for a corresponding wastewater treatment plant.

**Table 2.1.1.1- Site Options**  
**(Source: Preliminary Report 1994)**

<b>Scheme</b>	<b>Options</b>	<b>Population Equivalent</b>	<b>Required Area</b>	<b>Possible Location</b>
A	Waterford Environs (Plant A1)	20,900	1.5 -2 ha	Waterpark/Belmont/Ballymacloide
	Waterford City (Plant A2)	127,383	5 -6 ha	Abbeylands/Christendom (3 nr)/Kilmurry, Gorteens
B	Combined (Plant B)	148,283	6 - 7 ha	All sites above

The 1994 Preliminary Report includes an evaluation of Schemes A & B. This evaluation considered the costs and environmental factors with regard to the following:

- Minimisation of environmental impacts.
- Capital Costs.
- Operating & Maintenance Costs.
- Land Area Requirements.
- Suitability for future expansion.

For the purpose of a relative comparison between the two schemes (A and B), the unit processes and the mechanical components of the treatment plant were considered to be the same. The present and design loadings for the two alternative design schemes, A and B, are outlined in Tables 2.1.1.2 and 2.1.1.3. The main plant sizes in terms of volumes and capacities of the various unit processes for organic removal (i.e. carbon- BOD/COD) are outlined in Table 2.1.1.4.

From an environmental aspect the Preliminary Report noted the advantages of a combined wastewater treatment plant as proposed in Scheme B as follows:

- Centralisation of residual waste whereby disposal of bagged screenings, grits and sludge residue would be optimised from both environmental and economic standpoints in a single plant.
- The achievement of one outfall point with a common discharge standard for the entire drainage area. Separate outfalls involve separate monitoring and control facilities.



**Table 2.1.1.2**  
**Wastewater Treatment Plant - Options**  
**Present Loading (Summary)**

Options	Hydraulic (Max. pumped) m <sup>3</sup> /hr.	HYD. 6 DWF m <sup>3</sup> /hr	HYD. 3 DWF m <sup>3</sup> /hr	Organic kg BOD/day	COD kg/day	Suspended Solids kg/day	Total kg/day	Total K* kg/day
North Separate Plant A1	1,032	1,032	516	1,059	2,189	955	69	149
South Separate Plant A2	4,643	4,643	2,321	5,942	2,656	5,208	188	747
Combined Plant B	5,675	5,675	2,837	7,001	14,845	6,163	257	896

\*Kjeldahl Nitrogen

**Table 2.1.1.3**  
**Wastewater Treatment Plant - Options**  
**Design Loading (Summary)**

Options	Hydraulic (Max. pumped) m <sup>3</sup> /hr.	HYD. 6 DWF m <sup>3</sup> /hr	HYD. 3 DWF m <sup>3</sup> /hr	Organic kg BOD/day	COD kg/day	Suspended Solids kg/day	Total kg/day	Total K* kg/day
North Separate Plant A1	1,731	1,731	866	1,648	3,417	1,614	100	255
South Separate Plant A2	6,119	6,119	3,059	7,249	15,461	6,253	222	888
Combined Plant B	7,850	7,850	3,925	8,897	18,878	7,867	322	1,143

**Table 2.1.1.4****Volume & Capacities of Unit Processes - Carbon (BOD/COD) Removal  
Design Loadings**

Item	Description	Units	Plant A1	Plant A2	Plant B
1	Screen Construction Capacity	(m <sup>3</sup> /h)	1,732	6,119	7,845
2	Grit & Grease Removal Volume Total	(m <sup>3</sup> )	147	510	654
3	Flow Measuring Chamber Capacity	(m <sup>3</sup> /h)	866	3,059	3,925
4	Primary Sedimentation Volume	(m <sup>3</sup> )	554	1,958	2,512
5	Aeration Tank Volume	(m <sup>3</sup> )	1,496	6,579	8,074
6	Final Settlement Volume	(m <sup>3</sup> )	3,377	11,930	15,308
7	Primary Sludge Thickener Volume	(m <sup>3</sup> )	50	198	248
8	Biological Sludge Pre-dewatering Capacity	(kg SS/h)	100	500	600
9	Digester Volume	(m <sup>3</sup> )	750	3,175	3,900
10	Gasholding Tank (4 hours) Volume	(m <sup>3</sup> )	155	650	806
11	Sludge Dewaterer Capacity	(kg SS/h)	160	670	830
12	Storm Water Tank Volume	(m <sup>3</sup> )	289	1,020	1,308

- The advantage to be gained by advanced sludge treatment in the larger plant. This would not be economically justifiable in the smaller plant to serve the Waterford Environs.
- The economy of scale inherent in having a combined wastewater treatment plant. The cost per capita of treatment reduces considerably as population equivalent increases.
- By centralising all wastewater treatment into one location, all possible associated environmental impacts are centralised as well. It is environmentally preferable to utilise this one site rather than impacting two distinct areas.

The economic evaluation presented in the 1994 Preliminary Report is summarised in Table 2.1.1.5.

**TABLE 2.1.1.5 – COMPARISON OF COSTS FOR  
SCHEMES A AND B AT DESIGN LOADING**

Scheme	Capital Costs £m	O & M Costs/yr	NPV O & M Costs*
A	15.90	1.23	15.33
B	13.45	1.13	14.08
Difference	2.45	0.10	1.25

\* O & M (Operating & Maintenance) costs are capitalised over 20 years at 5% per annum.

It was concluded from this analysis that “the cost savings derived from the provision of a single wastewater treatment plant as against the provision of separate smaller plants in the north and south sides of the River Suir is £3.7M (which includes capitalised operating and maintenance costs of £1.25M). No comparable collection system cost savings can be achieved for separate schemes for the city and environs. Comparison between the most economical collection system for two separate wastewater treatment plants and the least economical of the viable collection systems to a single wastewater plant shows a cost saving of approximately £1.3M. This warrants the dismissal of the twin plant proposal on economic grounds.”

**Based on the above environmental and economic evaluation Scheme B was determined to be the preferred option.**

## 2.1.2 Alternative Wastewater Treatment Plant Locations

The wastewater treatment plant which is the subject of this Environmental Impact Statement, is to be located at Springfield House, Gorteens, Co. Kilkenny.

During preparation of the Preliminary Report nine potential sites for the location of an urban wastewater treatment plant to service Waterford City and Environs and South Kilkenny were considered (Refer to Figure 2.1.2.1). These potential sites were examined on the basis of engineering, environmental and economic considerations and a site at Gorteens was chosen as the preferred location of the proposed wastewater treatment plant.

As part of the consultation process, the Preliminary Report was presented to a joint sitting of Waterford Corporation and Kilkenny County Council (Piltown area) and at a separate date to representatives of the Belview Area Resident's Association. As a result of these consultations request were made to consider alternative sites in and around the site identified at Gorteens in the Belview Area. These included sites to the east of the port (as identified by consultants acting on behalf of Belview Resident's Association) and sites identified by other interested parties. The locations of these additional sites are shown in Figure 2.1.2.2.

### 2.1.2.1 Evaluation Methods.

All sites which were proposed as alternative locations for the wastewater treatment plant were assessed based on engineering, economic and environmental considerations.

Each site was evaluated according to the following criteria;

- Area of land required (this was estimated in the region of 7 hectares)
- Proximity to Waterpark Pumping Station (this station will handle the major flows to be pumped to the wastewater treatment plant).
- Elevation (this must be kept to a reasonable minimum to reduce pumping costs).
- Consistency with zoning and land-use objectives.

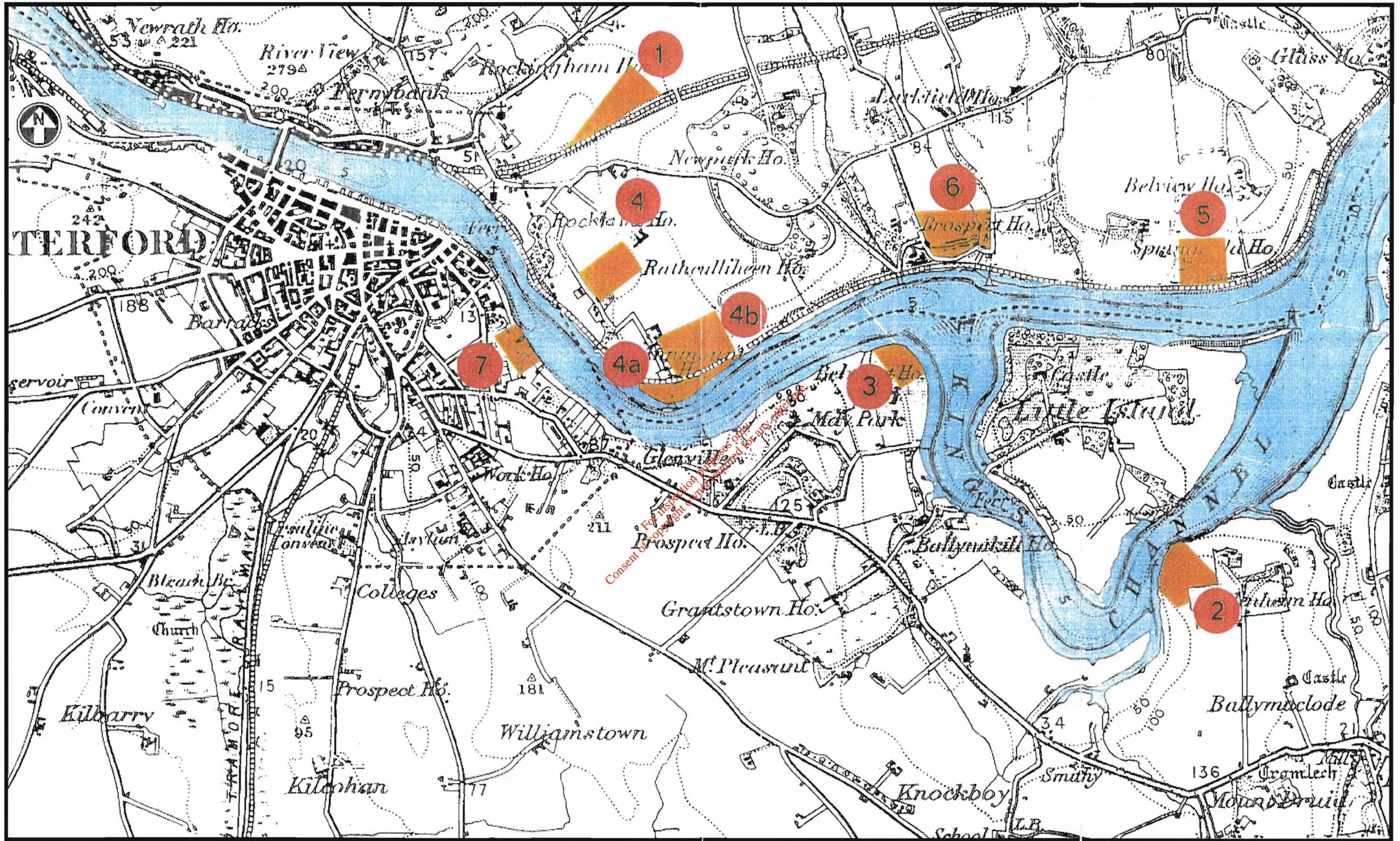

**LEGEND**

Site Nr. 1. Aabeylands	Site Nr. 4. Christendom	Site Nr. 5. Gorteens
Site Nr. 2. Ballymacclode	Site Nr. 4a. Christendom	Site Nr. 6. Kilmurry
Site Nr. 3. Belmont House	Site Nr. 4b. Christendom	Site Nr. 7. Waterpark

**Fig. Nr. 2.1.2.1  
Location Nine Alternative  
Sites Assessed in 1994**

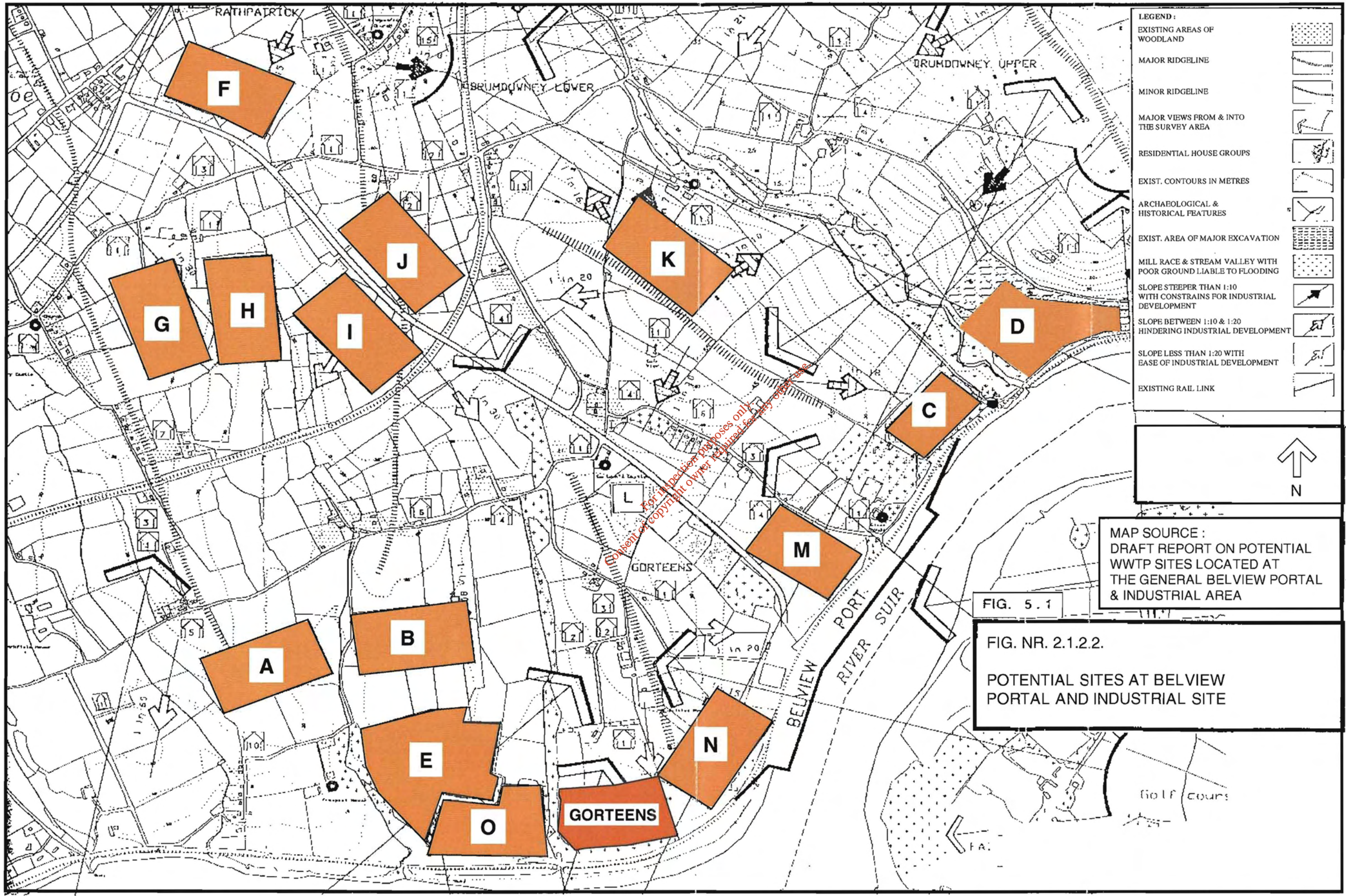

- Seclusion (this is necessary to minimise the environmental impacts such as aesthetics, off-site migration of air emissions, noise etc. of the proposed wastewater treatment plant).
- Proximity to residential areas (100 metres was considered a desirable distance to be maintained between the nearest component of the proposed plant and residential dwellings).
- Cost (The cost to construct, operate and maintain the collection system, pumping stations, outfall pipe, and wastewater treatment plant, must all be taken into account. This cost includes engineering constraints present at each site as well as site accessibility).
- Proximity to the point of discharge.

### 2.1.2.2 Sites Considered

The nine sites that were considered as alternative locations for the wastewater treatment plant during preparation of the 1994 Preliminary Report are detailed below:-

Abbeylands (Site No.1)  
 Ballymaclode (Site No. 2)  
 Belmont House (Site No. 3)  
 Christendom (Site No 4)  
 Christendom (Site No. 4A)  
 Christendom (Site No. 4b)  
 Gorteens (Site 5)  
 Kilmurry (Site No. 6)  
 Waterpark (Site No. 7)

Arising from consultations with Waterford Corporation and Kilkenny County Council (Piltown Area) and local residents the following sites were proposed as additional alternative locations.

- Sites North of Prospect House (Site A) and North of Springfield House (Site B).
- Site East of Port and Drumdowney Upper Site. (Sites C and D)
- West of Springfield House (Site E).
- A further 10 sites (identified as sites F, G, H, I, J, K, L, M and O), were chosen based on maximising their remoteness from existing dwellings.

In total 24 sites were examined.

### 2.1.2.3 Summary of Site Assessments carried out in 1994.

The following is a summary of the detailed assessment carried out on nine alternative sites in 1994.

Site ranking matrices based on engineering/economic and environmental considerations for each of the sites are presented in Tables 2.1.2.5. and 2.1.2.6, respectively. Each site is ranked on a scale from 0 to 5 under seven engineering/economic and seven environmental criteria to provide a simple overall indication of the comparative suitability of the sites.

It was concluded from Table 2.1.2.5 that sites No. 2 -Ballymaclode, 4A-Christendom, and 7-Waterpark present the greatest engineering/economic difficulties due principally to topography, size, access, and construction difficulties. Therefore, these sites were rejected as viable locations. Table 2.1.2.6 also shows that sites No. 3-Belmont House, 4-Christendom, 4A-Christendom, 4B-Christendom, and 7-Waterpark are the least attractive sites from an environmental viewpoint. The sites at Abbeylands and Gorteens emerged as favourable sites on environmental grounds with the site at Kilmurry also being worthy of retention for further consideration.

A further more detailed assessment of the remaining three sites was carried out. This assessment considered the receiving environments, and the likely impacts resulting from location of a wastewater treatment facility at each of these sites. The results of this assessment are summarised in Table 2.1.2.7. The Gorteens site was considered to be the most favourable site based on human environment, landscape and sustainable development considerations. The site at Gorteens, therefore, emerged as the preferred site for the location of a wastewater treatment plant.

### 2.1.2.4 Assessment of the Additional Sites identified during the Consultation Process

The locations of these sites are identified on Figure 2.1.2.2.

#### Sites A and B

The assessment of Sites A and B determined that from both a capital cost and operating and maintenance standpoint, both these sites were less economically viable when compared with the originally chosen Gorteens site. The assessment also showed that while these sites had no additional environmental advantages compared with the Gorteens site, the sites had a number of disadvantages which included higher



**TABLE NR. 2.1.2.5. Site Options for Wastewater Treatment Plant  
Engineering / Economic Considerations - Comparative Ranking Matrix**

Site No.	Location	Area (ha)	Elevation (MOB)	Site Development	Collection System	Access (M. Req'd)	Outfall Length (m)	Order of Cost £/M	Total
1	Abbeylands	10	10 - 31	250,000 m <sup>3</sup> excavation. Surplus for disposal.	Reasonably close to major contributors, remote from Maypark, etc.	Existing	1,500	15.6	
	Impact Ranking	1	3	3	2	1	5	1	16
2	Ballymacloide	7	5 - 35	Site very steep, heavy excavation req'd. Surplus for disposal.	5.5 km rising mains from Waterpark, remote from all contributors.	500	100	19.4	
	Impact Ranking	2	5	4	5	4	1	5	26
3	Belmont Hse.	7	10	Minimal.	Remote from major contributors, 2.2 km from Waterpark.	Existing	200	15.8	
	Impact Ranking	2	2	1	3	1	2	1	12
4	Christendom	7	8 - 25	200,000 m <sup>3</sup> excavation. Suplus for disposal.	As for site No. 1 above, but nearer to Maypark, etc.	300	500	15.0	
	Impact Ranking	2	3	3	2	3	3	0	16
4 A	Christendom	3.7	3.5	Major reclamation and piling. Pumping of effluent.	As for site No. 4.	500	100	19.4	
	Impact Ranking	5	4	5	2	4	1	5	26
4 B	Christendom	8	6 - 11	Minimal.	As for site No. 4.	500	200	14.9	
	Impact Ranking	2	2	1	2	4	2	0	13
5	Gorteens	7	3 - 13	Minimal.	3.5 km large gravity sewer.	300	300	16.5	
	Impact Ranking	2	2	1	4	3	2	2	16
6	Kilmurry	7	6 - 18	Balance cut & fill.	2.5 km large gravity sewer. Near minor contributors.	Existing	300	15.8	
	Impact Ranking	2	2	2	3	2	2	1	14
7	Waterpark	3.6	3.5	Reclamation of river, piling req'd. as for pumphouse.	Waterpark pump station adjacent. On-site pumping of effluent.	300	100	18.7	
	Impact Ranking	5	4	5	1	3	1	4	23

\* Excludes cost of Wastewater Treatment Plant as this is similar for all sites.

Note: (1) A ranking scale 0 - 5 is allocated for each engineering element considered as follows:

- 0 = Ideal Conditions.
- 1 = Low Constraints.
- 2 = Low to Medium Constraints.
- 3 = Medium Constraints.
- 4 = Medium to High Constraints.
- 5 = High Constraints.

(2) In Column 9 the lowest cost is ranked 0 and the highest cost is ranked 5 with intermediate costs ranked pro-rata.

**TABLE 2.1.2.6**  
**Site Options for Wastewater Treatment Plant**  
**Environmental Considerations - Comparative Ranking Matrix**

Site No.	Human Environment					Landscape	Natural Environment		
	2 Location	3 Land Use	4 Residences	5 Odour	6 Noise	7 Visual Resources	8 Water Quality	9 Flora/Fauna	10 Total
1	Abbeylands	3	2	1	1	3	1	1	12
2	Ballymacloide	3	2	1	1	5	1	1	14
3	Belmont Hse.	4	4	1	1	5	1	1	17
4	Christendom	5	1	3	1	3	1	1	15
4A	Christendom	2	2	1	1	5	4*	1	16
4B	Christendom	4	3	1	1	5	1	1	16
5	Gorteens	2	1	1	1	1	1	1	8
6	Kilmurry	2	4	1	1	3	1	1	13
7	Waterpark	4	4	1	1	4	1	1	16

\*Temporary impact due to foreshore reclamation.

Note: (1) A ranking scale 0 - 5 is allocated for each environmental element considered as follows:

- 0 - No Impact
- 1 - Low Impact
- 2 - Low to Moderate Impact
- 3 - Moderate Impact
- 4 - Moderate

**TABLE NR. 2.1.2.7. Comparison of Sites at Abbeylands, Gorteens & Kilmurry.**

Heading	Abbeylands	Gorteens	Kilmurry	Preference	Reasons for Preference
Topography	Site elevation relatively high. Heavy excavation costs.	Elevation ideal. Minimal site development costs.	Slightly higher than Gorteens. Steeper sloping than Gorteens.	G	Elevation & Topography are ideally suited to development for a Treatment Plant at a minimum cost.
Access	Access from main road. Improve existing passage.	Access would be through proposed Harbour Development roads, short extension required.	Improve approx. 0.6 km of rural road.	A	Costs of providing access to Abbeylands is most reasonable.
Proximity to Outfall Discharge Point	1,500 m.	300 m.	300 m.	Equal	Abbeylands has the longest outfall.
Existing Development	Approx. 200 metres from houses on main road. Sportsfield adjacent.	Approx. 150 metres from single residence.	Approx. 100 metres buffer zone required for 10 residences.	G	Satisfactory distance from nearest single residence.
Future Development	Residential zoned.	Agriculture.	Agriculture.	Equal	Abbeylands least compatible with zoning objectives.
Land Use / Landscape	Agricultural, semi - secluded.	Agriculture, secluded.	Agricultural, semi - secluded.	G	Site is more secluded and unobtrusive.
Flora / Fauna	Minimal effect.	Minimal effect.	Minimal effect.	Equal	Slight loss of habitat in each site.
Odour / Noise	Existing background noise relatively high. Odour minimal.	Remote from major developments. Odour minimal.	Buffer zone required to protect existing residences from noise and odour.	G	Site seclusion and proximity to zoned industrial development minimises effects.
Marine Environment	No impact.	No impact.	No impact.	Equal	Sites are removed from the Estuary shoreline.
Human Environment	Some effects on residents and amenity.	Some effects on occupants of single residence. No amenity.	Some effect on occupants of 10 residences. No amenity.	G	Site does not affect human environment apart from one residence, because of its remoteness & seclusion.
Traffic	Near main road.	Will pass through industrial roads.	Will pass residences on minor road.	A	Proximity with main road will enable traffic to merge quickly with general traffic.
Visual Impact	Minor impact on surrounding high ground.	Minimal visual impact.	Overlooked by nearby residences.	G	The seclusion and remoteness of the site reduces all impacts to a minimum.
Disposal of Residual Waste	As for traffic.	As for traffic.	As for traffic.	A	As for traffic.
Sustainable Development	Contrary to Development Plan.	Supports development in port area.	Some support for sustainable development.	G	Located adjacent to industrial zoned area.

density of dwellings within 500 metres of their boundaries, visual obtrusiveness, higher elevation and would require longer outfalls.

### **Site E and Site N**

These sites are located close to the Gorteens site which was the favoured site in 1994. Both of these sites would involve slightly higher capital and operating costs and Site N is directly overlooked by dwellings to the north-west. Site E is on a higher elevation than either the Gorteens site or Site O and would require additional pumping costs to convey the wastewater to this site.

### **Site C and D**

Sites C and D are located east of the port and are the sites identified by consultants acting on behalf of the Belview Resident's Association. However, these sites were proposed by the consultants as being suitable for the treatment of industrial and domestic flows from the Belview area only. No consideration was given to the treatment of wastewater pumped from the city areas. The evaluation of these sites indicated Site C has insufficient land area for a combined wastewater treatment plant and both sites would involve increased capital expenditure without any benefit from an environmental perspective.

### **Sites F, G, H, I, J, K, L and M**

In terms of site development, site access, site acquisition and operating and maintenance costs all the other sites were determined to be economically less attractive when compared to the Gorteens site (the preferred site in 1994).

The majority of sites are located inland from the River Suir and are at an excessively high elevation which would result in high annual operating and maintenance costs should a wastewater treatment plant be located at any of these sites.

Site M would require the removal and relocation of a fire water holding tank, car and truck parts and an access road in order to achieve sufficient area to accommodate the proposed wastewater treatment plant. In addition, with regard to the human environment perspective, housing densities in the vicinity of the majority of the sites are far greater than those sites located close to the river bank.

Therefore, it was considered impractical for the wastewater treatment plant to be located at any of these sites.

## Site O (The Proposed Site)

Site O (Springfield House Site) is directly adjacent to the Western Boundary of the Gorteens Site at a similar elevation. There is no significant difference in either the economical or environmental aspects for development of either site. However, the nearest residents to both this site and the Gorteens site (the preferred site in 1994) indicated that Site O is a more acceptable option. In addition, this site has been designated for the development of a wastewater treatment facility in the amended Kilkenny County Council Belview Area Action Plan 1997 (As amended May, 1998).

Therefore, the Springfield House site at Gorteens is the preferred location for a wastewater treatment plant to serve Waterford City and Environs (to include a portion of south Kilkenny).

### 2.1.3 Alternative Treatment Processes

The 1994 Preliminary Report included an assessment of alternative wastewater treatment processes suitable for a large urban wastewater treatment plant. This assessment considered the various unit processes as follows:

- Stormwater handling and disposal.
- Preliminary treatment, including screening and grit/grease removal.
- Primary settlement.
- Secondary treatment.
- Sludge Handling and Disposal.
- Advanced Sludge Treatment.

#### 2.1.3.1 Stormwater Handling and Disposal Strategy

An assessment of three separate strategies for the handling and disposal of stormwater at the treatment plant site was carried out. These strategies are shown schematically in Figure 2.1.3.1. This assessment concluded that Option C provides the most economically and environmentally acceptable system for effective control, treatment and disposal of potentially large quantities of stormwater.

Under Option C the full hydraulic load delivered to the treatment plant receives preliminary treatment. Downstream of preliminary treatment, flows in excess of 3 DWF are overflowed to separate stormwater settlement tanks. Flows up to 3 DWF are carried forward to primary settlement and the subsequent secondary treatment process. Settled stormwater which overflows from the stormwater tanks discharges with the secondary treatment plant effluent via the outfall pipe to the River Suir. Stormwater which is retained in the stormwater settlement tanks

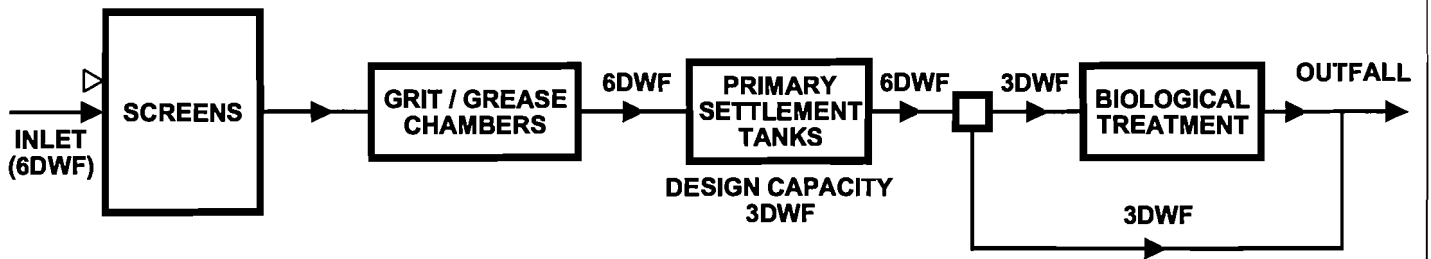

(A) STRATEGY 1

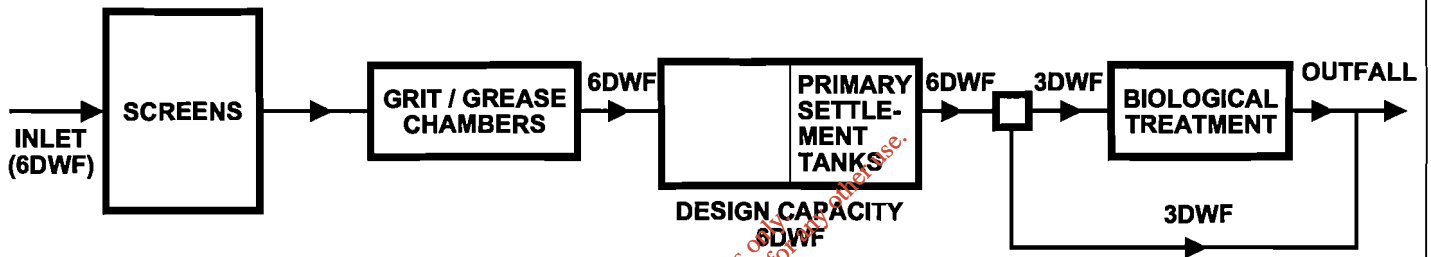

(B) STRATEGY 2

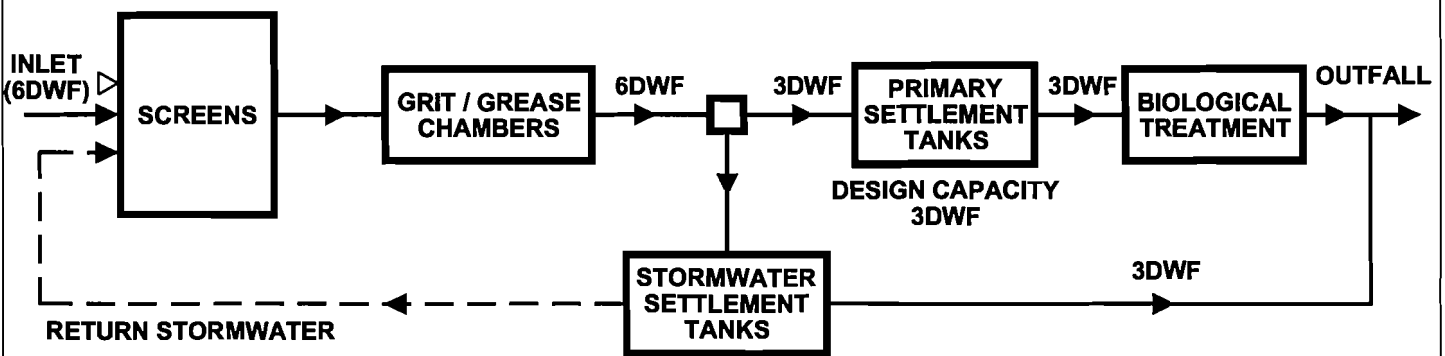

(C) STRATEGY 3

**FIGURE 2.1.3.1 ALTERNATIVE STORMWATER HANDLING AND DISPOSAL STRATEGIES AT WASTEWATER TREATMENT PLANT**

will be returned to the inlet works at controlled flow rates when the flow to the plant is decreased.

### 2.1.3.2 Preliminary Treatment

Preliminary treatment consists of screening, grit and grease removal. There are numerous screening systems available which would provide an appropriate solution. The screening system which will be adopted will be determined during the design phase. However, the screening system to be installed must be capable of providing screenings which are suitable for disposal to a landfill site. Other options for disposal of screenings include on-site burial or incineration. These alternative options were determined to be less environmentally acceptable than landfilling.

The alternative grit and combined grit/grease removal systems suitable for large wastewater treatment plants which were evaluated included:

- Spiral flow aerated grit and grease removal system.
- Vortex Separators.
- Sedimentation Tank/Constant Velocity Systems/Detritors.

The aerated grit and grease removal system was determined to be the preferred option for the following reasons:

- The settling velocity providing greater settling properties.
- Superior grease removal than the other options considered.
- Reduction of odour to downstream processes.
- Provides inherent grit washing.

### 2.1.3.3 Primary Settlement

Primary settling tanks can be either rectangular or circular type - the latter tend to be used more frequently in modern type plants. The lamella type clarifiers, which incorporate a series of parallel plates, are used as an alternative settlement system for specific applications particularly in cases of limited available area, these tanks tend to be very expensive to construct. Circular settlement tanks were determined to be the preferred option to be adopted for the scheme due to the associated advantages namely:-

- Fewer individual units required;
- More effective flow distribution;
- More efficient sludge collection.

### 2.1.3.4 Secondary Treatment

The processes of aerobic biological wastewater treatment which are most commonly and effectively used in large wastewater treatment plants are:-

- Activated Sludge (suspended-growth).
- Biological Filtration also referred to as Bio Filtration (attached-growth).

An assessment of the principal processes for the biological treatment of the Waterford Main Drainage wastewaters has been carried out. The processes assessed were activated sludge and biological filtration and variations of both. Due to the large land area requirement, associated odour problems and fluctuating effluent quality of the traditional percolating filters, the activated sludge process has been used on a universal basis from the 1960's onward. The adoption of plastic media in the 1970's in preference to stone media resolved a number of problems associated with the conventional trickling filter system. However, odour emissions and fluctuating effluent quality were still encountered at a number of plants. The concept of biological aerated filters (BAF) was developed in the late 1970's with the objectives of achieving consistent higher quality effluent, the elimination of nuisance caused by odour emissions and reduced space requirements.

The different processes for secondary treatment which were evaluated were:-

- Activated Sludge Treatment and configurations thereof including:-
  - Conventional Process
  - Contact stabilisation.
  - Sequencing Batch Reactors.
- Biological Filtration and Variations thereof including:
  - Conventional Trickling Filter.
  - Biological Aerated Filters (BAF)
  - Trickling Filter/ Solids Contact System.
  - Biological Tower.
  - Rotating Biological Contactor.

The conclusions of this assessment were that the conventional (high rate) activated sludge treatment system should be adopted for the treatment of the urban wastewater from the Waterford Main Drainage Scheme because of the following reasons:-



- It is a well documented treatment system suitable for large urban wastewater treatment plants. The system has been adopted universally for this purpose, particularly when starting with a 'green-field' scenario, i.e. no space restrictions.
- It minimises odour emission - the Aerobic Suspended Biomass System is less prone to odour emission compared to Bio Filtration (Attached-Growth/Fixed-Film) System.
- It allows for flexible modular type design, control and operation.
- Economically it compares favourably with other options.
- It facilitates effective biological phosphorus and nitrogen removal incorporating a combination of the recirculation and intermittent operation methods.

### 2.1.3.5 Sludge Treatment and Disposal

#### 2.1.3.5.1 Sludge Treatment

The main objective of sludge treatment is to render the sludge more amenable to disposal and to reduce the cost of disposal by reducing volumes and by producing a valuable by-product. Sludge treatment will generally take the form of thickening, stabilisation and dewatering. The alternative systems suitable for large wastewater treatment plants are outlined hereunder:-

#### Thickening

Sludge thickening processes effect an increase in the solids concentration of liquid sludge and thereby can substantially reduce the volume of sludge to be handled with consequent downstream cost savings. Options for thickening sludge which were considered include:

- Gravity Thickening.
- Dissolved Air Flotation.
- Centrifuge.
- Gravity Belt Thickening.
- Rotary Drum Thickening.

#### Stabilisation

The 1994 Preliminary Report investigated the following options for the treatment/stabilisation of the sludge:

- Mesophilic Anaerobic Digestion.
- Thermophilic Anaerobic Digestion.
- Conventional Aerobic Digestion.
- Thermophilic Aerobic Digestion.
- Co-digestion of Sewage Sludge and the Organic Fraction of Municipal Solid Waste.

Advanced sludge treatment options were also investigated which included:

- Composting
- Thermal Drying
- Incineration
- Pyrolysis
- Wet Air Oxidation

These and other options were evaluated in the preparation of the "Strategy Study on Options for the treatment and disposal of Sewage Sludge in Ireland", November 1993, which has subsequently been adopted as a policy document of the Department of the Environment. The other options investigated as part of that study included:

- Co-composting with Municipal Solid Waste (MSW)
- Lime Treatment
- N-Viro/Agri-soil process
- Bio-Drying
- Long-term storage.

The conclusions of the 1994 Preliminary Report and the Sludge Strategy Study both recommended Anaerobic digestion. The latter recommending co-composting with MSW as an alternative.

Further to the recommendations of the 1994 Preliminary Report, the requirements concerning the quality of sludge for landspreading are tending towards pasteurisation. It is therefore proposed that the sludge treatment process shall incorporate a pre-pasteurisation stage in advance of mesophilic digestion.

### **Dewatering**

Sludge dewatering is the physical (mechanical) unit operation used to reduce the moisture content of sludge. Dewatering in this context means the removal of water to the degree that the remaining sludge residue effectively behaves as a solid for handling purposes. Dewatering will increase the dry solids concentration of the sludge from 3.3% after digestion to 20%-25%. Several forms of dewatering were evaluated.

Filter Belt Press.

Plate Filter Press (Membrane Filter Press).

Centrifuge.

The preferred sludge treatment system to be adopted for the Waterford Main Drainage Scheme is summarised as follows:

### Thickening

Primary Sludge - Gravity Thickening.

Secondary Sludge - Gravity Belt Thickening.

### Stabilisation

Primary and Secondary Sludge - Mesophilic Anaerobic Digestion.

### Dewatering

Digested Primary and Secondary Sludge - Centrifuge/high pressure belt presses.

This system is a well proven and very effective form of sludge stabilisation and dewatering which is environmentally acceptable.

## 2.1.3.5.2 Sludge Disposal

The possible disposal routes for sludge generated from the treatment of the Waterford Main Drainage Scheme urban wastewater were identified as follows:-

- Disposal to Landfill.
- Landspreading.
- Disposal to Forestry/Land Reclamation/Dedicated Land.

The options for sludge disposal were evaluated with regard to national policy requirements concerning sustainable development and the protection of the environment. The EC Directive on Urban Waste Water Treatment (91/271/EEC) stipulates that sewage sludge shall be re-used when ever appropriate and the disposal routes that are chosen will minimise adverse environmental impacts (Article 14).

The Strategy Study (1993) has identified the proposed Waterford Main Drainage Wastewater Treatment Plant as a Hub-Centre for County Waterford and the southern environs of County Kilkenny. The sludge strategy report also indicates that the disposal options for the sludge should be -

- 1) Landspreading/forestry, and
- 2) Landfill with the latter being the least desirable option.

The 1994 Preliminary Report made the same recommendations, indicating that due to the limited availability of land, landfill will be an important disposal route in the short term.

## 2.1.4 Alternative Outfall Locations

The options for a suitable treatment plant site and the options for a suitable outfall location are in some respects interdependent. The Preliminary Report identified the preferred site at Gorteens.

Investigations into a suitable outfall location concentrated on this general location. The proposed location is in the main channel to the northeast of Little Island. This site was considered a suitable location for the following reasons:-

- proximity to preferred treatment plant site
- distance from existing shellfish cultivation areas
- distance from existing bathing areas
- depth of the channel at this location

The detailed analysis of this outfall concluded that this was a suitable location and as such no further outfall locations were considered.

The same criteria apply to the now proposed Springfield House site due to its close proximity to the originally preferred Gorteens site, and, as such, the outfall location remains the same as identified in the 1994 Preliminary Report as identified in Figure 2.2.1.1.

## **2.2 CHARACTERISTICS OF THE DEVELOPMENT**

### **2.2.1 Waterford Main Drainage Scheme**

The proposed development consists principally of the construction of a wastewater treatment plant to serve Waterford City and environs. The proposed wastewater treatment plant is an essential element of the Waterford Main Drainage Scheme. Associated works which will be carried out as part of this development include the construction of an access road, pumping station, and the laying of rising mains and gravity sewers to direct the wastewater to the new treatment works. A layout plan showing the scope of the Waterford Main Drainage Scheme is shown in Figure 2.2.1.1.

### **2.2.2 Site Location**

The site for the proposed wastewater treatment plant is located on an 18 hectare parcel of land in the townland of Gorteens, Co. Kilkenny, (see Figure 2.2.2.1). The site incorporates the ruined Springfield House (located on the north eastern section of the site). Springfield House itself is a designated listed building in the Kilkenny County Council Belview Area Action Plan 1997 (as amended May, 1998).

The proposed site is designated for the development of a wastewater treatment plant in the Kilkenny County Council, Belview Area Action Plan 1997 (as amended May, 1998) which has been formally adopted as part of the Kilkenny County Development Plan. The site designated as WT9, is to be developed in conjunction with LC2, a

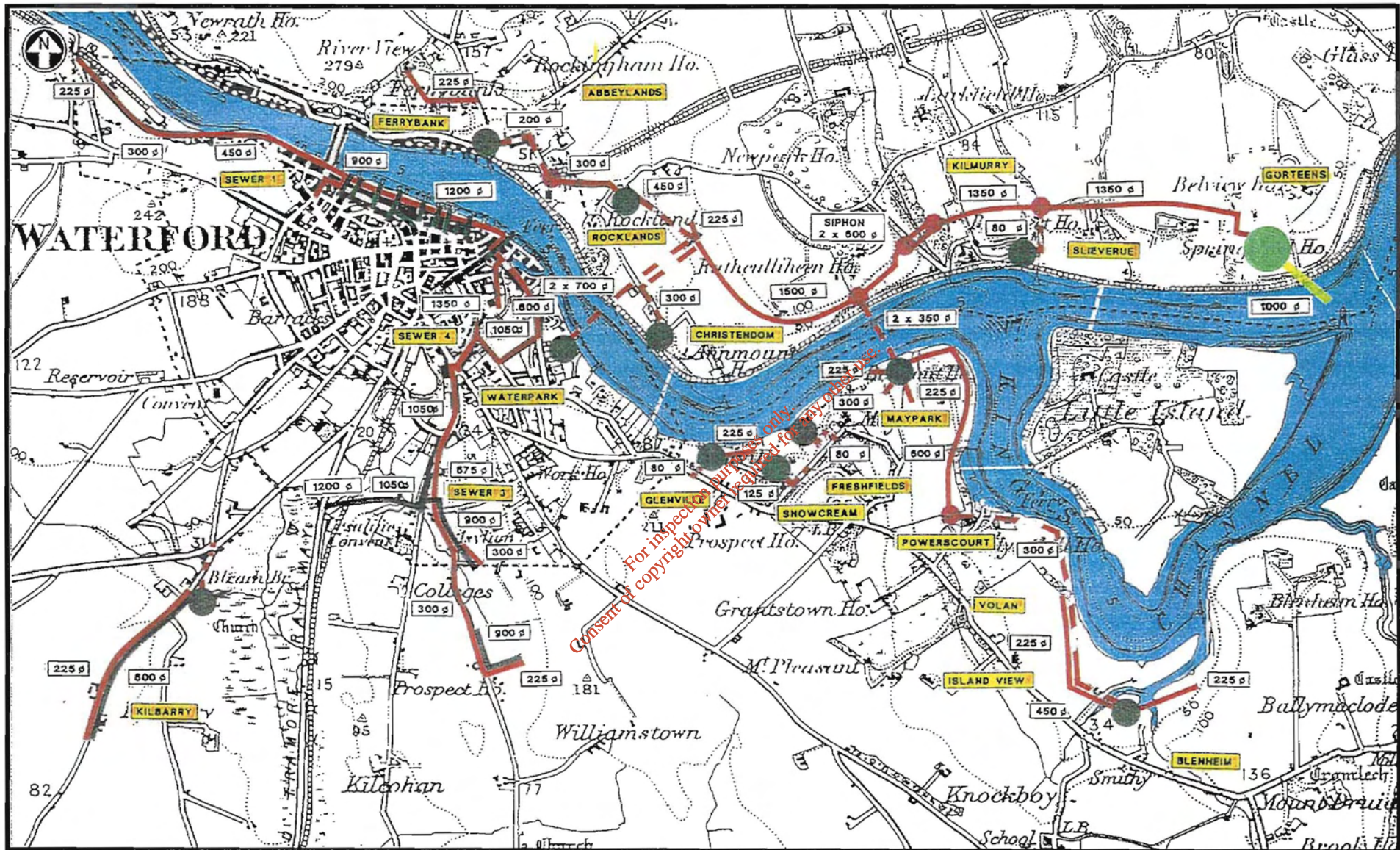

Legend:

Treatment Plant



Gravity Sewer (Foul)



Rising Main



Gravity Sewer (S.W.)



Outfall



Pump Station



Head Chamber



FIG. NR. 2.2.1.1.

Layout of Waterford  
Main Drainage Scheme  
(1994 Preliminary Report)



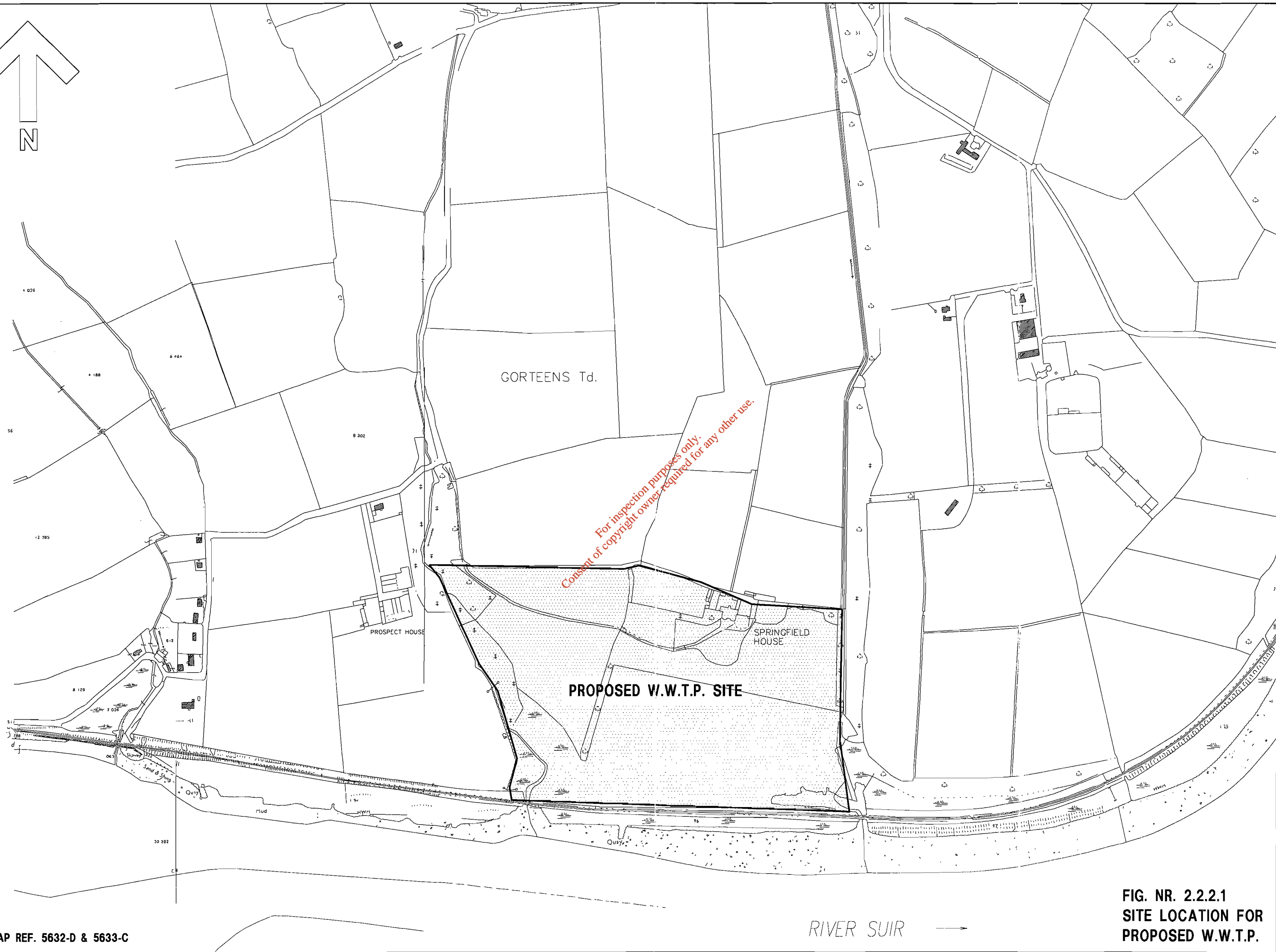
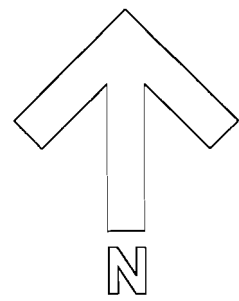

O.S. MAP REF. 5632-D & 5633-C

FIG. NR. 2.2.2.1  
SITE LOCATION FOR  
PROPOSED W.W.T.P.

compartment of land located to the north of the Springfield House site see Figure 2.2.2.2..

The Waterford-Rosslare railway line forms the southern boundary of the Springfield House site, with a railway embankment dividing the saltmarshes which form the border between the site and the river. A stream bounded by dense trees and vegetation on either side forms the eastern boundary of the site. A dense tree-line also forms the western boundary of the site of an existing unsurfaced access road to Springfield House. The elevation of the site slopes from 3m OD (Malin Head) adjacent to the river to 13m OD at the northern boundary.

### 2.2.3 Site Layout

The proposed site layout is illustrated on Figure 2.2.3.1.

The layout of the site avoids any interference with Springfield House structure or gardens. Some of the vegetation and trees that separate the old Springfield House gardens from the meadow to the south, will be removed in order to construct the administration building. In addition, the north-south running line of trees and vegetation that currently divides the site will be partially removed to allow for construction of the final settlement tanks.

The main structural elements of the wastewater treatment plant are listed in Table 2.2.2.1. The screening building, and grit removal buildings will be located at the north western corner of the Springfield House Site. All incoming effluent will initially pass through these buildings. A storm overflow chamber and inlet monitoring chamber will be located immediately downstream of these buildings. There will be two covered primary settlement tanks (1.0m above ground level) downstream of the monitoring chamber. These tanks will be located above ground between 9 and 11m OD on the site. A selector tank, extending 1.2m above ground level, will be located adjacent to the second settlement tank. East of the selector tank, upstream and downstream of the aeration tanks, provision has been made for future nutrient removal facilities. Five rectangular aeration tanks will be located in the centre of the site. These tanks will be 1.0m in height above ground level. Provision has been made for a further three aeration tanks. A blower building will be located south of the aeration tanks. This building will be 5.625m above ground level.

Five final settlement tanks will be located south of the aeration tanks. Provision has been made for a further three tanks. The settlement tanks will be circular concrete tanks with an internal diameter of 31 metres. Sludge return pump sumps will be located to the east of the first, third and fifth settlement tanks.

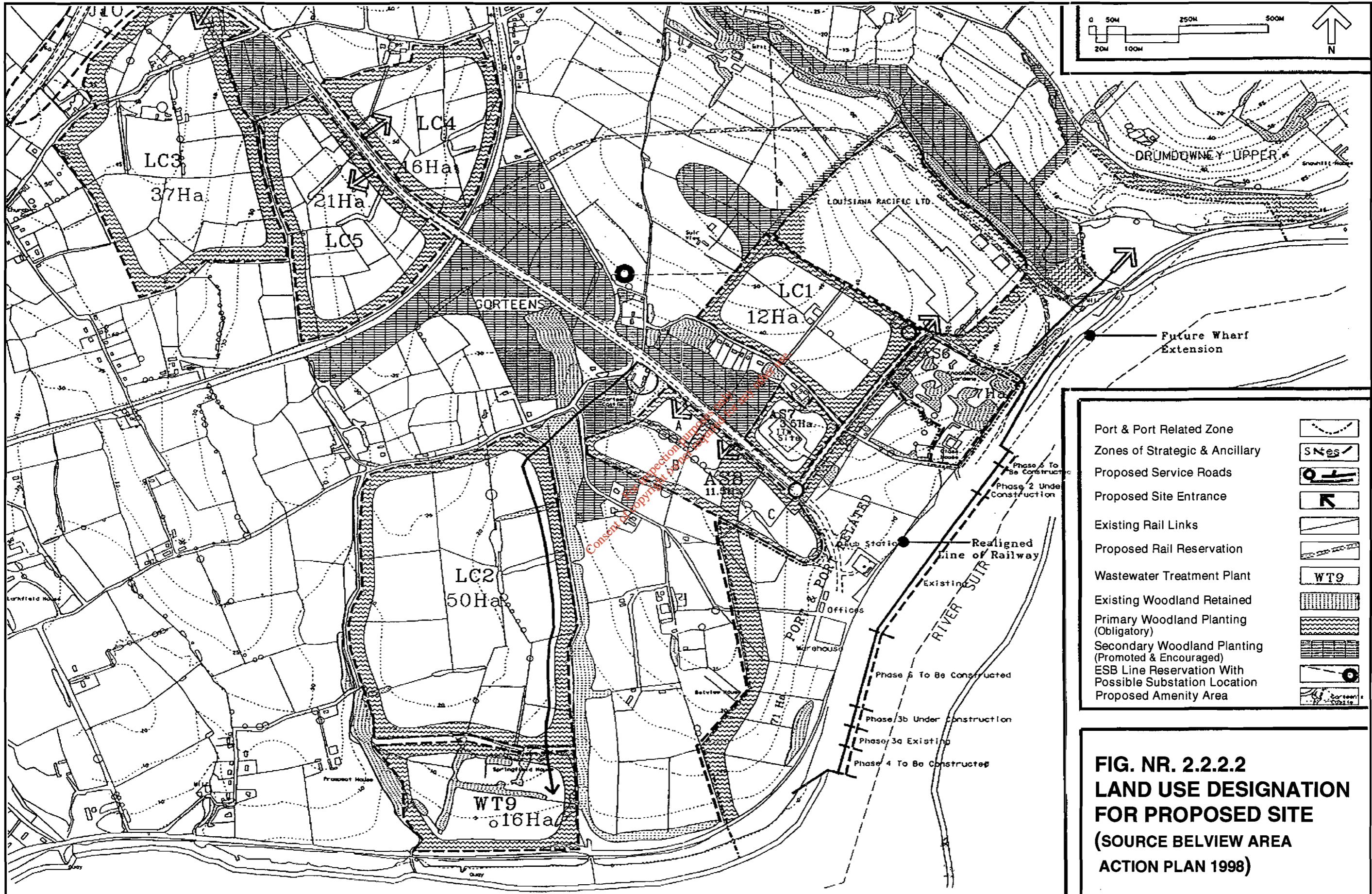

**FIG. NR. 2.2.2.2**  
**LAND USE DESIGNATION**  
**FOR PROPOSED SITE**  
 (SOURCE BELVIEW AREA  
 ACTION PLAN 1998)



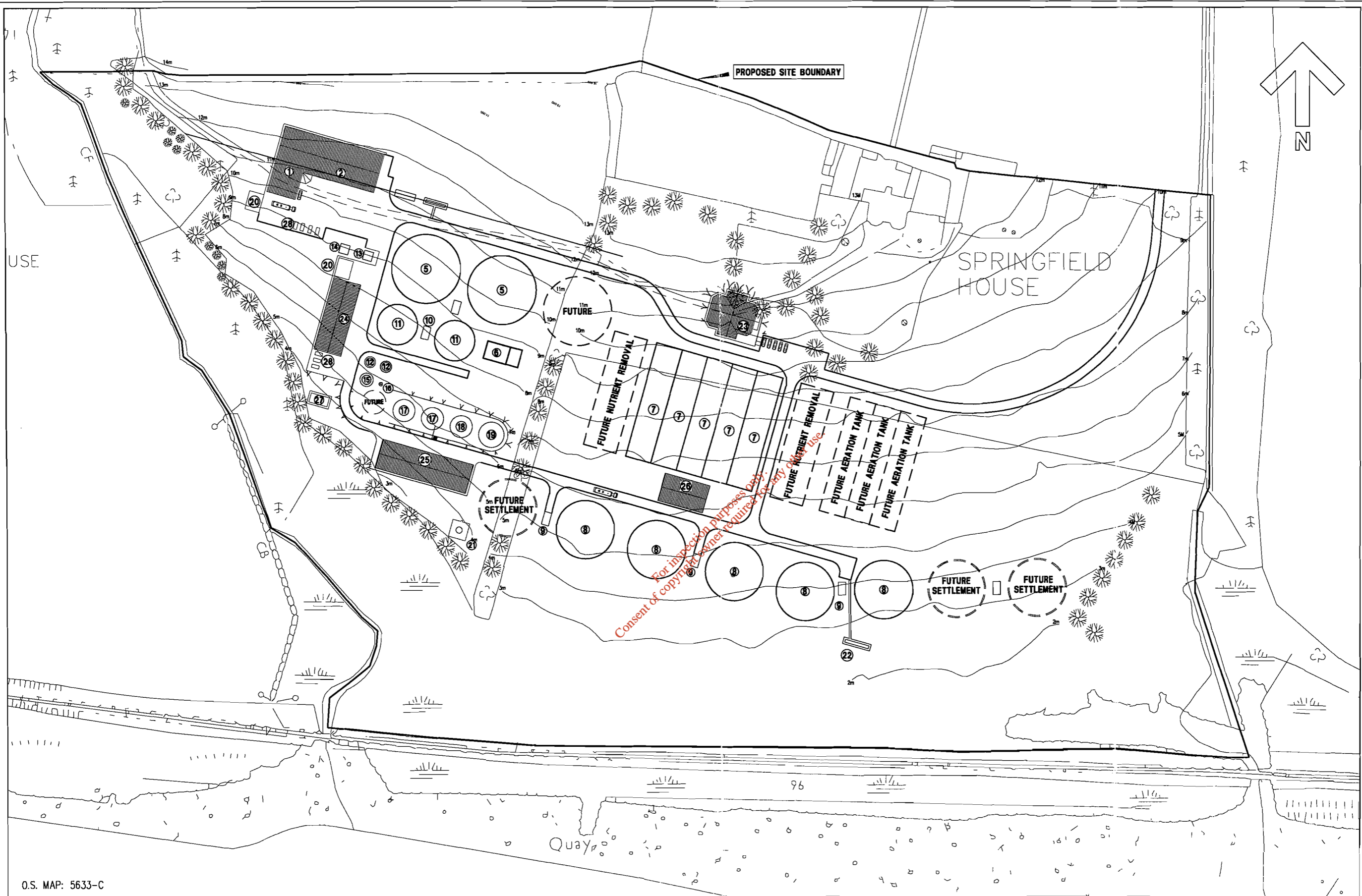

O.S. MAP: 5633-C

**PLANT LEGEND:**

- |                            |                                     |                              |   |
|----------------------------|-------------------------------------|------------------------------|---|
| ① SCREENING BUILDING       | ⑧ FINAL SETTLEMENT TANK             | ⑮ SLUDGE BLENDING TANK       | ⑳ DISCHARGE MONITORING CHAMBER            |
| ② GRIT REMOVAL BUILDING    | ⑨ ACTIVATED SLUDGE RETURN PUMP SUMP | ⑯ SLUDGE PASTEURISATION TANK | ㉑ ADMINISTRATION BUILDING                 |
| ③ STORM OVERFLOW CHAMBER   | ⑩ STORM WATER PUMP SUMP             | ⑰ SLUDGE DIGESTERS TANKS     | ㉒ SLUDGE THICKENING / DEWATERING BUILDING |
| ④ INLET MONITORING CHAMBER | ⑪ STORMWATER TANKS                  | ⑱ DIGESTED SLUDGE TANK       | ㉓ SLUDGE DIGESTION CONTROL BUILDING       |
| ⑤ PRIMARY SETTLEMENT TANKS | ⑫ SLUDGE THICKENERS TANKS           | ㉀ GAS HOLDING TANK           | ㉔ BLOWER BUILDING                         |
| ⑥ SELECTOR TANK            | ⑬ IMPORTED SLUDGE RECEPTION         | ㉁ ODOUR CONTROL UNIT         | ㉕ PROPANE TANK                            |
| ⑦ AERATION TANKS           | ⑭ SLUDGE PUMP SUMP                  | ㉂ SURPLUS GAS BURNER         | ㉖ SKIP HOLDING AREA                       |

**FIG. NR. 2.2.3.1  
LAYOUT OF WASTEWATER  
TREATMENT PLANT**

**Table 2.2.2 - Principal Elements of the Development**

No	Structure	Size	Materials of Construction	Colour
1&2	Screening & Grit Removal Building	1,300 m <sup>2</sup>	Concrete walls with profiled sheeting on roof	Buff walls with dark green roof
3	Storm Overflow Chamber	10 m x 3 m below ground level	Concrete construction with metal decking cover	
4	Inlet Monitoring Chamber	11 m x 2 m below ground level	Concrete construction with metal decking cover	
5	Primary Settlement Tanks (2 Nr)	Circular with 36.5 m dia. x 1 m sidewall above ground level	Concrete walls with GRP roof	
5a	Primary Sludge Sump	5 m x 6 m below ground level	Concrete walls and roof	
6	Selector Tank	13.0 m x 10.5 m with a sidewall height of 1.2 m above ground level	Concrete	
7	Aeration Tanks (5 Nr)	64 m x 14 m with a sidewall height of 2 m above ground level	Concrete walls	
8	Final Settlement Tanks (5 Nr)	Circular with 31 m dia. x 1 m sidewall above ground level	Concrete walls	
9	Activated Sludge Sumps (3 Nr)	7 m x 6 m below ground level	Concrete walls and roof	
10	Stormwater Sludge Sump	5 m x 6 m below ground level	Concrete walls and roof	
11	Stormwater Storage Tanks (2 Nr)	Circular with 21.4 m dia. x 1 m sidewall above ground level	Concrete walls	
12	Primary Sludge Thickener (1 Nr)	Circular with 6 m dia. x 4 m sidewall above ground level	Glass enamelled steel walls with GRP roof	Dark green walls and roof
13	Imported Sludge Screening Unit (1 Nr)	7 m x 2 m with a total height of 2.5 m above ground level	Stainless steel enclosure	Grey
14	Imported Sludge Mixing Sump	9.6 m x 6.6 m below ground level	Concrete walls and roof	

**Table 2.2.2 - Principal Elements of the Development**

No	Structure	Size	Materials of Construction	Colour
15	Sludge Blending Tank	Circular with 6 m dia x 3.5 m sidewall above ground level	Glass enamelled steel walls with GRP roof	Dark green walls and roof
16	Sludge Pasteurisation Tank	Circular with 2.5 m dia x 4.5 m sidewall above ground level	Glass enamelled steel walls with GRP roof	Dark green walls and roof
17	Sludge Digester Tanks (2 Nr)	Circular with 12 m dia x 14 m sidewall above ground level	Glass enamelled steel walls with GRP roof	Dark green walls and roof
18	Digested Sludge Storage Tank (1 Nr)	Circular with 12 m dia x 14 m sidewall above ground level	Glass enamelled steel walls with GRP roof	Dark green walls and roof
19	Biogas Holder (1 Nr)	Circular tank with 13.7 m dia x 12.7 m sidewall above ground level	Glass enamelled steel walls with GRP roof	Dark green walls and roof
20	Odour Control Units (2 Nr)	10 m x 10 m x 2.5 m sidewall above ground level	GRP enclosure	Green
21	Waste Gas Burner (1 Nr)	Circular with 3.7 m dia. x 4.3 m sidewall height above ground level	Steel enclosure	Dark green
22	Discharge Monitoring Chamber	13 m x 2 m below ground level	Concrete construction with metal decking cover	
23	Administration Building	500 m <sup>2</sup>	Concrete walls with profiled sheeting on roof	Buff walls with green or dark grey roof
24	Sludge Thickening & Dewatering Building	15 m x 40 m	Concrete walls with profiled sheeting on roof	Buff walls with dark green roof
25	Digester Control Building	15 m x 50 m	Concrete walls with profiled sheeting on roof	Buff walls with dark green roof
26	Blower Building (1 Nr)	15 m x 25 m	Concrete walls with profiled sheeting on roof	Buff walls with dark green roof
27	Propane Tank	1,000 litres	Reinforced plastic	Dark green

The stormwater pump sump and storm water tanks will be located to the south of the first primary settlement tank. The top of these tanks will extend 1.0m above ground level.

Two primary sludge thickener tanks will be located south of the stormwater tanks. These tanks will be covered and will extend 4.0m above ground level. Each tank will be 5.97m in diameter.

The sludge pump sump and covered imported sludge reception tank will be located west of the settlement tanks, on the western side of the site. An odour control unit will be located between this tank and the sludge thickening and dewatering building. This building will extend 7.13m above ground level.

The sludge blending tank will be located adjacent to the primary sludge thickening tanks. Each tank will extend 4.0 m in height above ground level and will be 9.38m in diameter and will be constructed of a glass lined steel.

The sludge pasteurisation tank will be located adjacent to the sludge blending tank. This tank will be covered and will extend 5.0m above ground level and will be 2.5m in diameter. Downstream of the sludge pasteurisation tank there will be two covered (dome roofed) sludge digester tanks. Provision has also been made for a third tank. The tanks will be 15m in height above ground level and will be 12.8m in diameter. Downstream of these tanks there will be a domed roofed digested sludge tank. This will have an elevation of 15m (relative to ground level) and be 12.8m in diameter. Adjacent to the sludge digester tanks (west) the sludge thickening/dewatering building will be located. A skip area will be provided below the sludge thickening/dewatering building.

A gas holding tank, 13m in height and 12.8m in diameter will be located adjacent to the digested sludge tank.

The sludge digestion control building will be located on the south-western corner of the site adjacent to the relevant sludge digester and digested sludge tanks. The building will be 7.13m above ground level and clearly visible from the southern boundary of the site. A standard fuel tank containing propane will be located to the west of the control building.

A discharge monitoring chamber will be located on the south-eastern corner of the site prior to the outfall location.

The administration building will be located in the middle of the site, south of Springfield House gardens.

An outfall pipeline will be laid from the site to the point of discharge at the confluence of the Queen's Channel and King's Channel north east of Little Island. This will require a tunnel crossing of the railway track.

The proposed development also includes a comprehensive landscaping plan which has been developed in accordance with the requirements of the Belview Area Action Plan (as amended May 1998). An illustration of the extent of the proposed landscaping plan is shown on Figure 2.2.3.2

## 2.2.4 Description of the Design

**2.2.4.1** The proposed wastewater treatment plant's design will meet the effluent standard as required by the Environmental Protection Agency Act 1992 (Urban Wastewater Treatment) Regulations, 1994 (S.I. Nr. 419 of 1994). These regulations require that wastewaters from agglomerations of more than 15,000 PE shall receive secondary treatment prior to discharge. In this context the required discharge standard which shall apply is:

Biochemical Oxygen Demand - 25 mg/litre  
Total Suspended Solids - 35 mg/litre

The effluent recipient water is the Suir Estuary which has not yet been designated as a "sensitive" or "less sensitive" area by the Department of the Environment in accordance with the terms of the EC Directive on Urban Wastewater Treatment (91/271/EEC). Therefore, nutrient removal (i.e., nitrogen and phosphorus) is not required at present. However, this situation may change in the future. The proposed wastewater treatment plant is designed to allow easy retrofitting of nutrient removal facilities at a later stage if required.

**2.2.4.2** There are 15 existing outfalls discharging untreated wastewater into the River Suir. These are identified and illustrated in Figure 2.2.3.1 and 2.2.4.1. Under the proposed sewerage scheme, each of these outfalls will be intercepted, and the wastewater will be transported to the treatment plant at Springfield House for treatment prior to discharge to the River Suir through a single outfall north east of Little Island. The total estimated wastewater load from Waterford and environs is outlined in Table 2.2.4.1

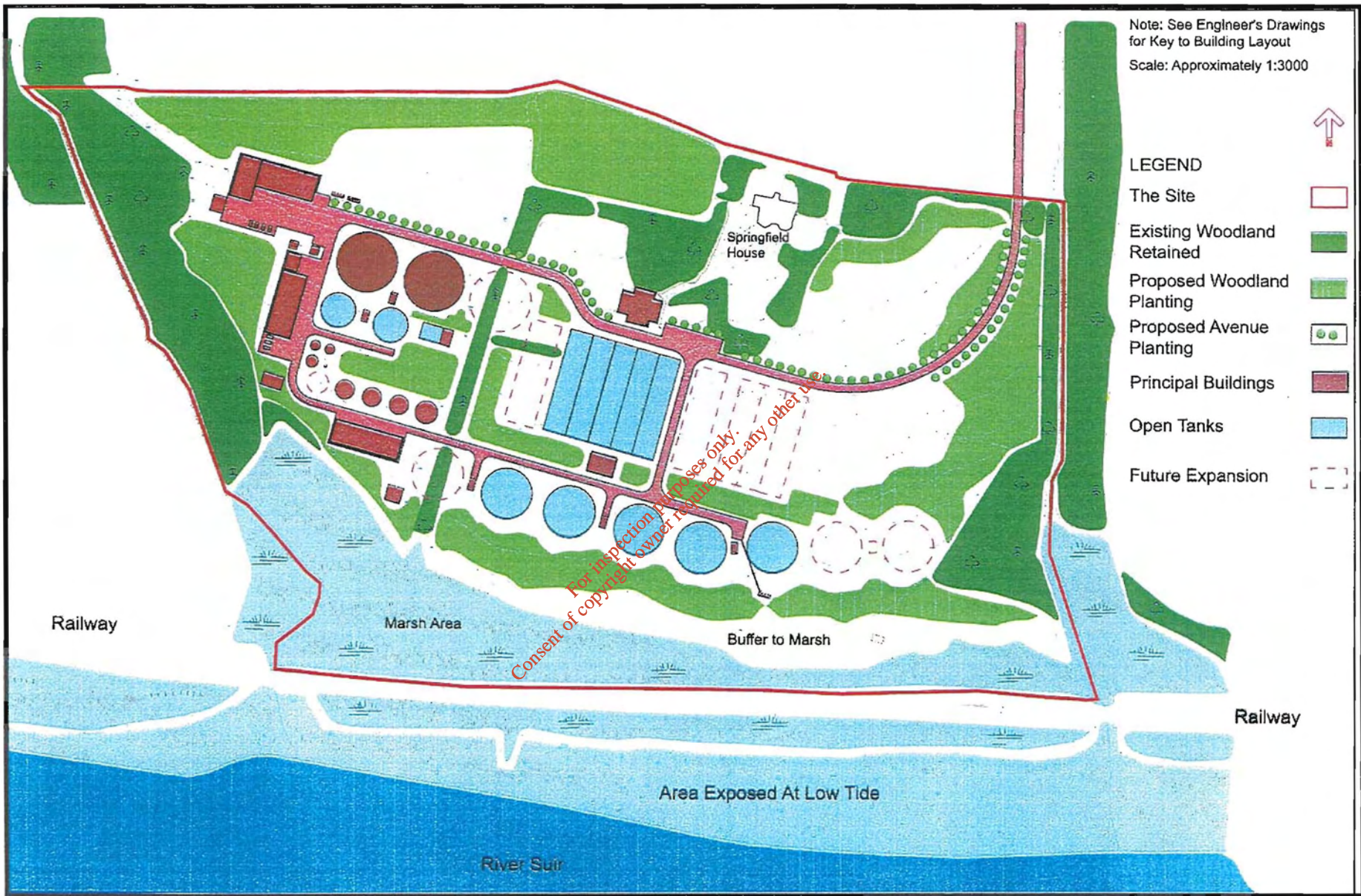
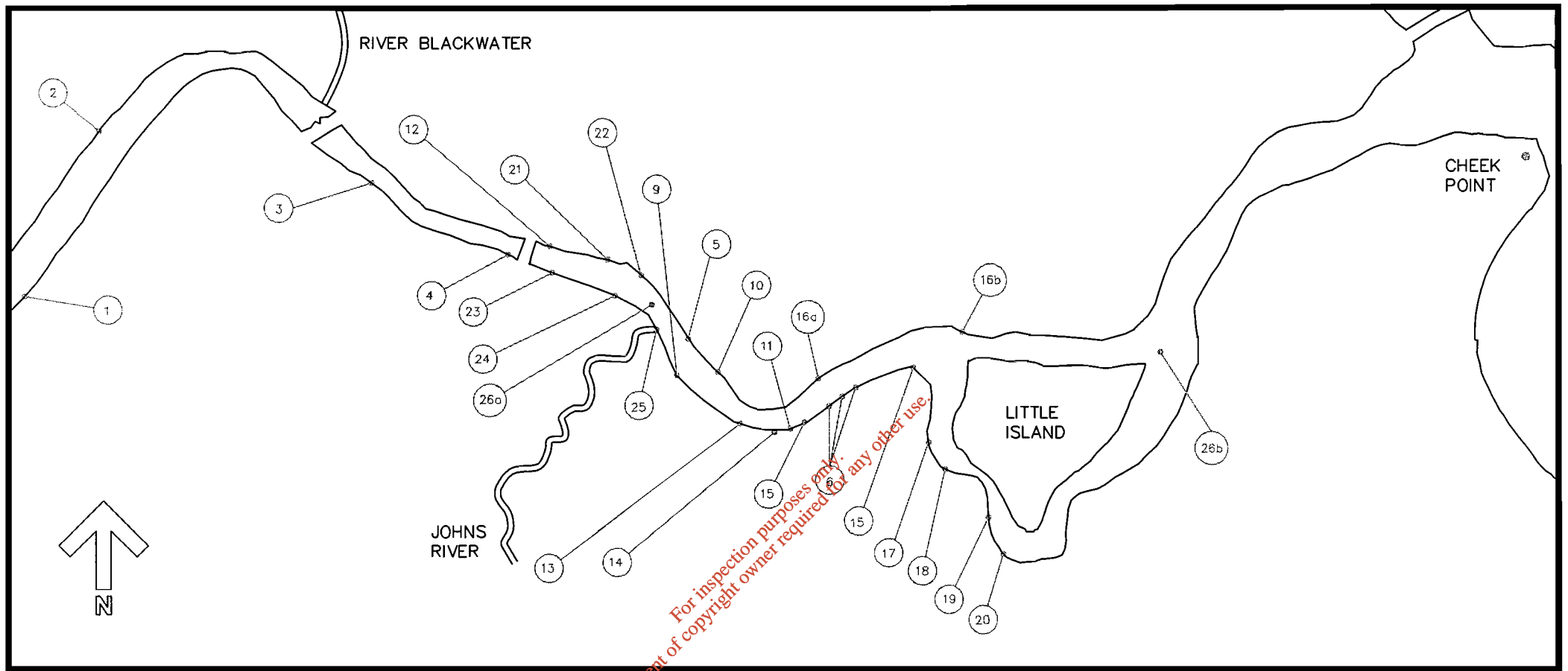

FIG. NR. 2.2.3.2.  
LANDSCAPE PLAN



EXISTING INDUSTRIAL OUTFALLS	
No.	LOCATION
1.	KNOCK HOUSE
2.	GRANNAGH
3.	GRACEDIEU EAST
4.	RICE BRIDGE
5.	CHRISTENDOM
6-8.	REGIONAL HOSPITAL
9.	WATERPARK
10.	RATHCULLIHEEN
11.	GLENVILLE
12.	FERRYBANK

EXISTING URBAN OUTFALLS	
No.	LOCATION
13-15.	GLENVILLE, SYCAMORE, FRESHFIELD
16.	KING'S CHANNEL
16a.	ABBAY PARK
16b.	SLIEVERUE
17.	MARIAN TERRACE
18.	BALLYNAKILL
19-20.	VOLAN, ISLAND VIEW
9.	WATERPARK
21.	FERRYBANK
22.	ROCKLANDS, ROCKSHIRE
23.	BRIDGE ST. TO BARRON STRAND
24.	CONDUIT LANE & JOHN'S RIVER
25.	JOHN'S RIVER-STORM OVERFLOWS

PROPOSED WASTEWATER TREATMENT PLANT OUTFALL OPTIONS.	
No.	LOCATION
26a.	ABBEYLANDS
26b.	GORTEENS

⊕ Figure 2.2.4.1 : Locations of existing urban and industrial outfalls and proposed wastewater treatment plant outfall options.

**Table 2.2.4.1****Estimated Wastewater Load**

Estimated Loading	DWF m <sup>3</sup> /d	BOD kg/d	Suspended Solids kg/d	P kg/d	TKN** kg/d
Present -1998 Untreated	18,752	9,045	5,890	244	833
Future - 2025 (Design) Untreated	26,000	11,295	7,906	323	1,079
Future (Ultimate*)	39,000	15,195	10,974	445	1,352

*\*Note: 'Ultimate' loads refers to wastewater generated by possible future industrial development at Belview.*

*\*\*TKN – Total Kjeldahl nitrogen.*

The estimated wastewater loadings presented in Table 2.2.4.1 include for contributions from domestic and industrial sources. The 1994 Preliminary Report reports an industrial wastewater survey which was conducted, using on-site wastewater flow monitoring and sampling, assessment of completed detailed questionnaires, results of laboratory analysis of the flow-proportional samples, and metered water consumption. The results of this survey are presented in Appendix B.

The Industrial wastewater element of the estimated wastewater load is shown in Table 2.2.4.2 .

**Table 2.2.4.2****Industrial Wastewater Loads**

Loads	Flow	BOD	P	TKN
Present -1998	6,644	3,060	63	140
Future - 2025	12,531	7,110	117	277

**2.2.4.3** The estimated overall land area requirement for the proposed wastewater treatment plant, including facilities for organic-material removal, nutrient removal, and advanced sludge treatment (if ultimately required), is *7.1 hectares*. This figure is based upon the sizes of the individual processes and the estimated sizes of the various service buildings.



**2.2.4.4** The proposed components of the wastewater treatment process are described below and a schematic process flow diagram is given in Figure 2.2.4.2.

### **Stormwater Handling, Treatment, and Disposal**

Raw wastewater is diluted with stormwater during rainfall events from surface runoff and infiltration entering the collection system. The wastewater treatment plant will provide preliminary treatment (screening and grit removal) for flows up to approximately 6 times the Dry Weather Flow (6 DWF). Flows up to 3DWF will receive primary and secondary treatment.

After the preliminary treatment stage, flows in excess of 3DWF will overflow, to storm holding tanks. The contents of the storm holding tanks will be pumped back through the treatment plant at times when the inlet flow is reduced. When the capacity of the storm holding tanks is exceeded the overflow is mixed with the treated effluent prior to discharge to the receiving waters.

#### **Screening.**

Screening refers to the removal of solid materials from the wastewater as it arrives at the treatment plant. The treatment process includes for the installation of screens with a bar spacing of 5mm. Washing and compaction of the solids will be provided. Screened materials will be bagged and removed in skips for disposal to landfill.

#### **Grit and Grease Systems.**

Grit and grease removal facilities are to be provided downstream of the screens. The principal function of this system is the removal of grit particles and grease from the influent wastewater flow in order to protect pumps and mechanical equipment from damage and excessive wear in subsequent stages of treatment. Under design loading conditions, it is estimated that approximately 1m<sup>3</sup> of grit per day will be generated at the treatment plant site. The ultimate disposal of the grit will be to landfill. Grease will discharge to the anaerobic sludge digestion process for treatment/degradation.

#### **Primary Sedimentation.**

From the grit/grease removal system the wastewater flows by gravity to the Primary Sedimentation process. The purpose of primary sedimentation is to remove the maximum amount of polluting matter in the form of readily settleable solids from the wastewater as quickly and as economically as possible. Primary sedimentation will occur in two 37m diameter radial flow tanks. The solid material which settles in the

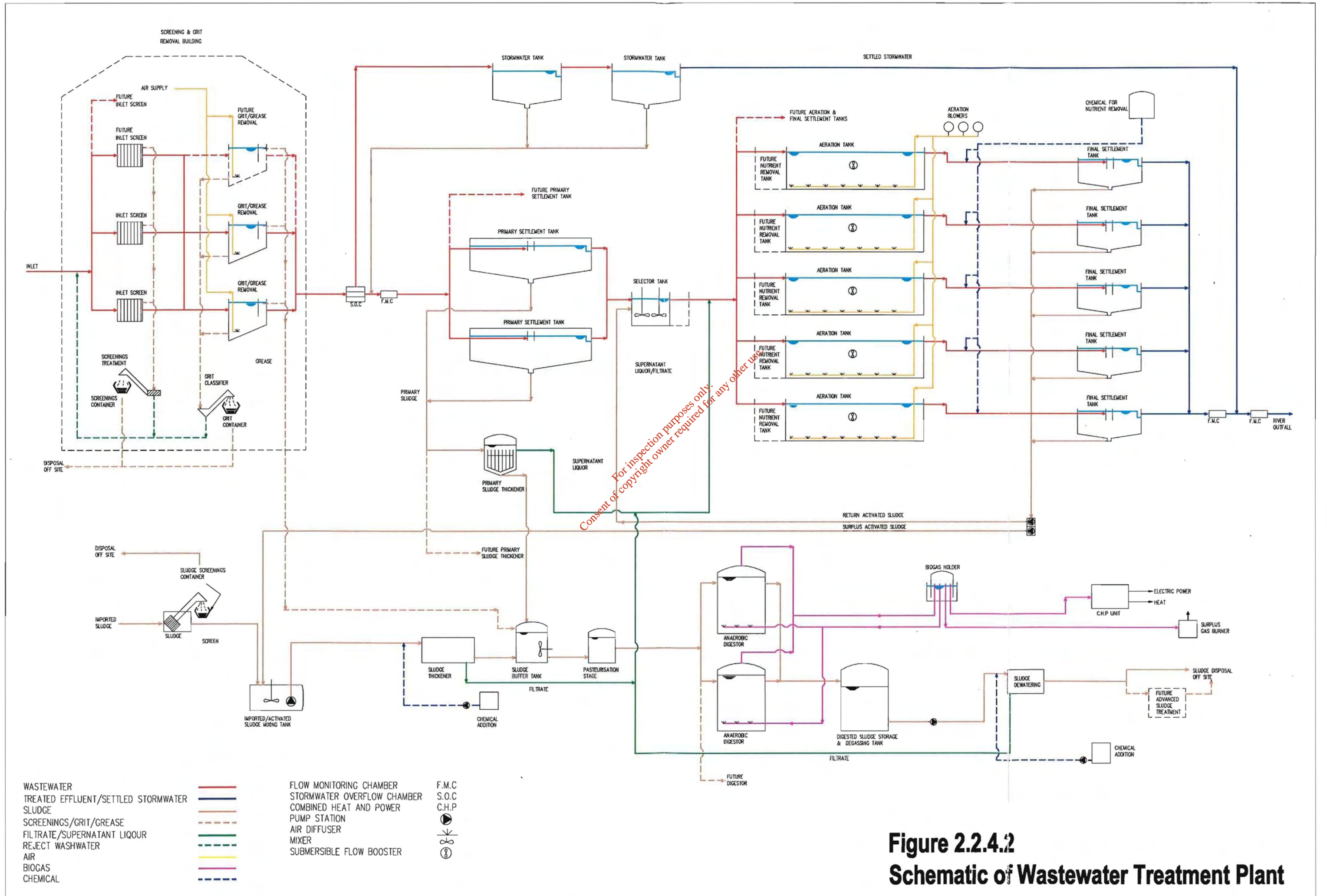

**Figure 2.2.4.2**  
**Schematic of Wastewater Treatment Plant**

sedimentation tanks (primary sludge) will be thickened in sludge thickening tanks prior to feeding to the sludge treatment process.

## Secondary Treatment

Settled wastewater from the primary sedimentation tanks will be further treated in a biological treatment process. The proposed treatment process is the Activated Sludge Process. The physical components of this process include aeration tanks, secondary sedimentation tanks (clarifiers), return sludge pump sumps, and a blower building. This is an aerobic treatment process and, as such, is generally considered odour-free.

The activated sludge process is the most commonly used process for the treatment of urban wastewater. The process essentially involves the degradation of the organic material in the wastewater using micro-organisms. The micro-organisms occur naturally in the wastewater and by providing the correct environment (dissolved oxygen level, pH, temperature, retention time) the micro-organisms proliferate in the aeration tanks. The wastewater is held in the aeration tanks for sufficient time for the micro-organisms to degrade the biodegradable material to meet the required effluent standard. When this is complete the treated wastewater is separated from the micro-organism in the final clarifiers and the settled biomass is returned to the aeration tanks or wasted as secondary waste activated sludge to the sludge treatment process.

## Sludge Treatment

The by-product of the activated sludge process is waste activated sludge. In the proposed treatment process waste activated sludge will be thickened, blended with on-site primary sludge and treated in a sludge digestion process. The proposed digestion process includes a pre-pasteurisation stage followed by mesophilic digestion phase. The digestion process reduces the volatile organic fraction of the sludge which results in a stabilised end-product (odour-free). The function of pre-pasteurisation stage is to reduce the pathogens which are contained within normal sewage sludge, thereby making the sludge a safer product for subsequent handling and disposal. The treated sludge is dewatered and disposed off-site for landspreading and landfilling.

Biogas is a valuable by-product of the sludge digestion process. It is projected that the biogas will contain in excess of 75% methane which will be burned in an on-site Combined Heat and Power (CHP) plant. Facilities will be provided for gas storage and an enclosed flare will be provided for emergency use.

The sludge treatment facilities are sized to cater for sludges produced on-site and for sludges imported from other smaller wastewater treatment plants in parts of Waterford and South Kilkenny.

### **2.2.5 Construction**

The construction phase for the wastewater treatment plant will extend over a 24 month period with a start date anticipated in spring/summer of 2000. The timing for the construction of the wastewater plant will depend upon the completion of other associated works.

The construction works associated with this development will involve normal construction activities such as excavation, filling, lifting, pumping, pipelaying, concrete works, mechanical installation etc. Other more specialised techniques may include piping, tunnelling and marine works. Blasting is not envisaged for this development.

Site accommodations including offices, stores, workshops, canteens, etc will be located within the boundary of the development site. Likewise parking facilities for construction vehicles and private transportation will be located within the development site. Temporary site fencing will be erected and maintained to secure the site during the construction phase.

### **2.2.6 Commissioning**

It is expected that the wastewater treatment plant will be put into operation immediately on completion of construction. However, the full capacity of the plant may not be utilised for some years as the design capacity is to the year 2025.

It is expected that mechanical, electrical and process commissioning will extend for approximately 12 weeks after start-up of the plant. Process commissioning may involve the importation of a seed activated sludge from other wastewater treatment plants.

### **2.2.7 Operation**

The wastewater treatment plant will be operational 24 hr/day, 365 day/year. It is not anticipated that the plant will be staffed 24 hrs/day. The normal working hours will be typically 8.00am – 6.00pm Monday to Saturday.

It is anticipated that 6 full-time employees will be required to operate the wastewater treatment plant. A typical staffing structure is outlined hereunder:

<b>Management / Administration</b>	1 x Engineer/Supervisor
<b>Treatment :</b> (Preliminary, Primary, Secondary and Sludge)	1 x Laboratory Technician 2x General Operatives *
<b>Maintenance</b>	1 x Electrician** 1 x Fitter**

\* Also utilised for site maintenance

\*\* Utilised for the entire scheme (Pumping Stations and Collection System).

The plant will be substantially automated and controlled by a SCADA (Supervisory Control and Data Acquisition) system. All critical control functions will be linked to alarms with automatic dial-out facilities to alert maintenance staff.

Monitoring and sampling facilities are to be provided at the inlet and outlet of unit process to monitor plant efficiency and performance.

On-site lighting will be provided for access and maintenance purposes. Flood lighting will be used to illuminate items of plant and equipment when required for maintenance and shall be activated locally. Continuous night time lighting will be provided on access roads and other locations only as required for safety reasons. These will consist of low pressure sodium lamps controlled by photocells.

Safety measures at the wastewater treatment plant site will provide for the requirements of all plant personnel and will limit access to the site by unauthorised persons. Safety features will include the following:-

- Handrails to uncovered tanks where appropriate.
- Handrails and toe-board to access platforms walkways etc.
- Controlled access to all stairs and platforms.
- Safety chains/cages to units/ladders where appropriate.
- Safety grid flooring to all ducts and channels
- Local emergency stop buttons to be provided on all machinery.
- Life buoys will be provided at strategic locations around all tanks.
- Hadrian rails and harnesses for maintenance personnel.
- Perimeter security fence with an intruder alarm system linked to the central control station

These measures are incorporated in the plant design to minimise risk to all plant personnel/visitors/intruders.

## 2.2.8 Associated Development Works

The proposed wastewater treatment plant is one element of the Waterford Main Drainage Scheme. The other elements of the scheme essentially consist of interceptor sewers, rising mains, pumping stations and gravity sewers. The major elements of the scheme which have been constructed to date include:-

- Waterpark Pumping Station
- Interceptor Sewers Nr. 3 & 4.

Interceptor Sewer Nr. 1 is due for construction in spring 1999.

The other elements of the scheme which have yet to be constructed include:-

- Twin 700 millimetre rising mains from Waterpark Pumping Station to connect to a gravity sewer to be laid on the Kilkenny side of the River Suir.
- Interceptor Sewer Nr. 2; This section of the collection system consists of separate foul and stormwater sewers to serve existing and proposed development in land adjoining Kilbarry Road. Including a pump station at Bleach Bridge.
- Sycamore/Glenville and Freshfields – A collection system to integrate a low-level developed area north of Dunmore Road will consist of three small pumping stations with associated rising mains. These stations will utilise package-type submersible pump systems. The first station will be located at Glenville adjacent to a small wooded area abutting the mudflats. It will be necessary to lay a 225 millimetre sewer along the river bank to connect development at Sycamores to this station. The second station will be located adjacent to Freshfield and a derelict boathouse, and will collect wastewater from a number of houses presently served by a septic tank. The third station will be located adjacent to the Snowcream factory near Dunmore Road.
- Maypark Pumping Station and Rising Main; This pumping station will be the focal point for collection of wastewater arising in the “Added Area” east of Waterpark Pumping Station. The station will house four submersible pumps. It will be located adjacent to the existing wastewater treatment facilities serving the Ardkeen Regional Hospital at Maypark. Wastewater from the hospital as well as from new development at Maypark Village and the Moorings will flow directly to the station, in

independent sewers. From the pumping station at Maypark, twin 350 millimetre rising mains will be laid across the River Suir estuary to link into a gravity sewer for transportation of wastewater to the proposed site for the wastewater treatment plant. Twin mains are proposed for security reasons and to cater for variations in flow.

- Gravity Sewer to Treatment Plant; A large-diameter gravity sewer will commence at Christendom and follow a route eastwards via Newtown, Abbeypark, Kilmurry, and Gorteens to the proposed site. This pipe will be 1,500 millimetres in diameter in its upstream section, and will have an inverted siphon arrangement where it crosses a deep valley east of Abbeypark. The inverted siphon will consist of twin 600 millimetre-diameter pipes, which will discharge to a 1,350 millimetre sewer, and form the downstream section of the gravity pipeline.

The route of this gravity pipeline has been carefully chosen through relatively open countryside with a view to minimising excavation, achieving adequate grades, avoiding existing developments, and minimising the number of stream crossings in the area. The head chamber of this sewer will receive the pumped flows from Waterpark Pumping Station.

- Rockshire Sewerage Scheme; Connection of the two drainage systems serving Rockshire and Rocklands will involve replacing the existing comminutor stations at Rocklands and Ferrybank with pumping installations. Rising mains will be laid from the new Ferrybank pumping station to a high-level head chamber near the school and convent at Abbey Road, and from the Rocklands station to the Abbeypark head chamber joining the Waterpark and Christendom rising mains.
- Additional Pumping Stations; Three additional pumping stations will be incorporated into the drainage scheme. The Christendom pumping station will be located adjacent to the existing outfall for AIBP Meats. A submersible-type installation will connect to a 300mm rising main to be laid partly in the same trench as the Waterpark mains.
- The Blenheim pumping station will be located just west of Blenheim Heights in the low-lying land at the head of a small inlet of the King's Channel. From there, a 225mm rising main will pass northwards along the shoreline, coinciding with the proposed new riverside amenity walkway, to the existing tank at Powerscourt.

flows from the Maypark pumping station and the Abbeypark head chamber of the Rockshire Sewerage Scheme.

## Collection System

Approximately 51% of the roughly 16,650 metres of gravity sewers and rising mains will be constructed within public roadways. A detailed listing of distances of specific roadways to be traversed is provided in Table 2.2.8.1. The majority of the roads are within Waterford City, although a limited number occur on the Kilkenny side of the River Suir.

Agricultural fields and pastures will be traversed by approximately 19% of the collection system. These areas lie on the north side of the River Suir, primarily between the head chamber joining the Rocklands, Waterpark and Christendom rising mains and the proposed wastewater treatment plant site at Springfield, Gorteens, Co. Kilkenny

Other land uses to be traversed include open spaces (i.e. grassy areas and gardens, 6%), industrial/commercial such as the Snowcream factory (2%), and recreation (i.e. a pitch and putt course near John's Villas) (< 1%). Distances of land types to be traversed are presented in Table 2.2.8.2.

The Rocklands pumping station will be located adjacent to the existing commuter station. Pumping stations at Ferrybank, Christendom, Freshfield, Glenville, Snowcream, and Bleach Bridge will be located in open, grassy areas. In addition, approximately 20% of the collection system passes through natural areas including grassy marsh (14%), woodlands (2%), and the River Suir (4%) and John's River (<1%). The marsh areas occur principally along the King's Channel and the River Suir near Belmont House. The Maypark, Blenheim, and Slieverue pumping stations will be located in similar silty foreshore areas. Wooded areas to be traversed include approximately 300 metres on the north side of the River Suir, and a small area just east of the Glenville pumping station.



**Table 2.2.8.1****Roadways to be Traversed by the Proposed Collection System**

<b>Roadway</b>	<b>Distance Traversed (m)*</b>
Bilberry Road	1,600
Merchant's, Meagher's & Custom House Quays	1,200
Lombard St.	100
Bolton St.	200
Penrose Lane	75
Thomas St.	75
Hanover St.	75
Gladstone St.	75
Barronstrand St.	75
O'Connell St.	200
Sargent's Lane	50
Conduit Lane	75
Exchange St.	100
St. George's St.	50
Keyzer St.	75
Henrietta St.	75
Parnell St.	100
The Mall	300
Kilbarry Road	775
Glenville Park	350
Freshfield	275
Maypark Lane	150
Ballynakill Ct.	375
Bishopsgrove	275
Fountain St.	575
Abbey Rd.	475
Miscellaneous Roads	700
<b>Total</b>	<b>8,450</b>

\*Distances are approximate.

The River Suir will be crossed at two locations - Maypark and Waterpark. The river is approximately 300 metres wide at these points. Also, the John's River will be crossed near the Bleach Bridge. Other waterways within the proposed wayleave include a small inlet of the King's Channel near the Blenheim pumping station, and two small streams on the north side of the River Suir both of which will be culverted.

**Table 2.2.8.2**

**Major Land/Habitat Types to be Traversed by the Proposed  
Collection System**

<b>Land/Habitat Type</b>	<b>Distance Traversed (m)*</b>	<b>Percent of Total</b>
Roadway	3,450	51%
Agricultural / Pasture	3,200	19%
Marsh	2,375	14%
Open Space/Field	1,325	8%
River	700	4%
Woodland	300	2%
Industrial/Commercial	300	2%
<b>Total</b>	<b>16,650</b>	

### 2.2.9 Power and Water Supply

Currently there is a limited supply of water to the Belview area which is provided through an extension from Abbeylands which is taken from the reservoir supply from the Mount Sion reservoir. There are plans in existence to provide additional water supplies to the Belview Area which will improve the existing supply.

Water for use during the construction phase and during operation of the wastewater treatment plant will be piped from the existing public water supply system.

Power supply to the plant will be taken from the existing overground 10 KV main power line to the Port. Routes for any additional high tension lines into the Belview area have been designated in the Belview Area Action Plan 1997 (as amended May 1998). and reservations have also been made for electrical sub-stations. The route for the overhead power supply line to the wastewater treatment plant site will follow the access road to the site. The Electricity Supply Board has confirmed that sufficient capacity is available from the existing 10KV network to

service the proposed wastewater treatment plant which requires approximately 1MW. All cables within the site boundary will be distributed underground.

The use of biogas produced in the anaerobic sludge digestion process to generate heat and power will reduce the overall external energy requirements of the wastewater treatment plant. The CHP generation plant will provide sufficient power to operate critical items of the plant in the event of power failure.

*For inspection purposes only.  
Consent of copyright owner required for any other use.*