

JOHN MOLLOY ENGINEERING

8, Willowfield Park, Goatstown, Dublin 14.
Telephone: 01 - 298 9188 Fax: 01 - 298 7421
E-mail: molloyeng@eircom.net



Mr. Joe Fox,
Mahon & Fox,
The Bullring,
Wexford.

28 August 2004

Re: On-site sewage disposal for Goff Recycling at Kilrane, Co. Wexford.

Dear Joe,

In the attached design sheet, we calculate the design load to be 160g BOD/day and 240litres/day. For this application we would recommend a two part treatment process consisting of:

1. Secondary Treatment to a 20mg/L BOD and a 30mg/L Suspended Solids standard in a Klargester Model BB as per the enclosed drawing and leaflet. This is a completely self contained treatment plant having with it three separate zones for: Primary Settlement, Oxidation by slowly rotating discs and Humus Settlement. The plant is designed to cater for 12 persons in a residential situation. The plant has Irish Agreement Certificate No. 01/0094.

It should be followed by,

2. Tertiary Treatment/Disposal in a raised percolation area. In the accompanying Design Sheet, and based on a average T₁₀ value of 10mins/25mm we calculate the required length of subsurface trench to be 6.4m. We recommend 2 rows, each 5m long. The percolation system should be laid out in accordance with BS6297. Each trench should be 0.9m wide and there should be 2m of undisturbed ground between each trench. The pipes should be laid a minimum of 1m above the existing ground level with 1m of topsoil under them. The percolation should be surrounded with a french drain which must discharge to a natural outfall. The separation distance between the percolation area and any well(s) should be in accordance with SR6.

A relevant brochure and drawing are enclosed. Site levels will determine if pumping is required.

Yours sincerely,

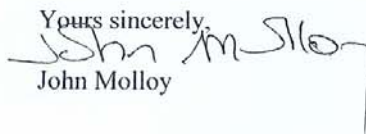
John Molloy



DESIGN SHEET

Site: Goff Recycling

Effluent standard 20mg/l BOD and 30mg/l suspended solids

Design load

Source	Quantity	G/day BOD	Total g/day BOD	litres/day	Total litres/day
Staff	8	20	160	30	240
Total			160		240

Percolation system.

Nature of system: raised using imported top-soil with an average T value of 10 minutes/25mm (24sec/mm). In accordance with BS6297, the area of the sub-surface percolation trench $A_t = \rho \times V_p \times 0.2$

Where

$$\begin{aligned}\rho &= \text{population equivalent} \\ &= 240/200 \\ &= 1.2\end{aligned}$$

and

$$T = 24 \text{ sec/mm}$$

Therefore,

$$\begin{aligned}A_t &= 1.2 \times 24 \times 0.2 \\ &= 5.8 \text{m}^2\end{aligned}$$

Assuming 0.9m wide trench, the length of trench required = $5.8/0.9$. This corresponds to 6.4m. We suggest 2x5m rows. Each trench should be 0.9m wide and there should be 2m of undisturbed ground between each trench



CI/SFB
(52.3)

Klargester Environmental Limited
College Road, Aston Clinton, Aylesbury, Bucks. HP22 5EW.
Tel: 0044 (1296) 633000 Fax: 0044 (1296) 633001

KLARGESTER BIODISC

Systèmes de traitement des eaux résiduaires
Abwasseraufbereitung

The Irish Agrément Board is designated by Government to issue European Technical Approvals.

Irish Agrément Board Certificates establish proof that the certified products are 'proper materials' suitable for their intended use under Irish site conditions, and in accordance with the **Building Regulations 1997 to 2000**.

The Irish Agrément Board operates in association with the **National Standards Authority of Ireland (NSAI)** as the National Member of UEAtc.

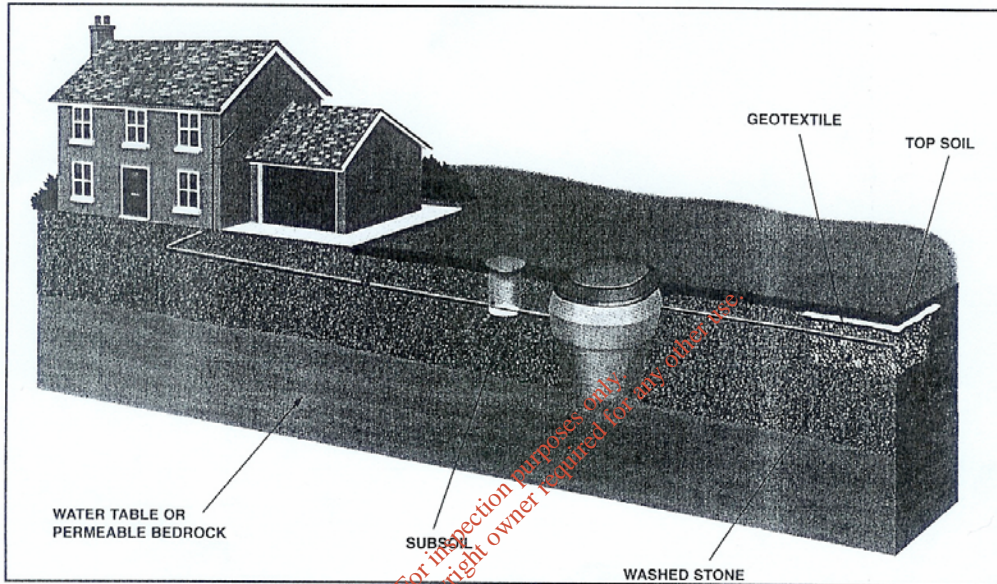

PRODUCT DESCRIPTION:

This Certificate relates to Klargester BioDisc (Confirmation of Certificate No.86/1700, Detail Sheet No.6 issued by the British Board of Agrément, PO Box No.195, Bucknalls Lane, Garston, Watford, Herts WD2 7NG. UK).

installation of small sewage treatment works and cesspools. The unit is used for the retention and treatment of domestic wastewater, and the settlement of humus solids in suspension, prior to discharge of the treated effluent.

USE

The product is for use in sewage treatment systems and for sewage collection systems designed in accordance with BS 6297: 1983 Code of practice for design and

MANUFACTURE AND MARKETING

The product is manufactured and marketed by Klargester Environmental Limited, College Road, Aston Clinton, Aylesbury, Bucks. HP22 5EW.

PART 4 CERTIFICATION

1.1 ASSESSMENT

In the opinion of the Irish Agrément Board (IAB), the Klargester BioDisc is satisfactory for the purpose defined above, and meets the requirements of the Building Regulations 1997 to 2000 as indicated in Section 1.2 of this Certificate.

1.2 BUILDING REGULATIONS 1997 TO 2000 Requirement: D & H

D1 & D3 – MATERIALS AND WORKMANSHIP.

D3 – The Klargester BioDisc as certified in this Irish Agrément Board Certificate, is comprised of "proper materials" and is fit for its intended use (see Part 4 of this certificate).

D1 – The Klargester BioDisc used in accordance with this Irish Agrément Board Certificate, meets the requirements for materials and workmanship.

Readers are advised to check that this Certificate has not been withdrawn or superseded by a later issue by contacting: Irish Agrément Board, NSAI, Clonsilla, Dublin 9.

PART H – DRAINAGE AND WASTE DISPOSAL

H1 Drainage systems:

The Klargester BioDisc is easily installed and incorporated into soil percolation to meet Building Regulation requirements.

H2 Septic tanks

The Klargester BioDisc has been designed for use in wastewater treatment systems, for the collection and treatment of domestic wastewater when installed in accordance with the recommendations of BS 6297: 1983: *Code of practice for design and installation of small sewage treatment works and cesspools* and the E.P.A. *wastewater treatment manuals – Treatment Systems for Single Houses*. The quality of treated

wastewater from the Klargester BioDisc Wastewater Treatment System exceeds that of the effluent from a septic tank and will meet the building regulation requirements.

Information on the design capacity ventilation, safety and location requirements is given in this Agrément Certificate (see sections 2.4, 3.2 and 4.6 of this certificate). The Klargester Wastewater Treatment System can be used in domestic situations where septic tank systems are not acceptable, where sites do not comply with the recommendations of S.R.6. 1991 *Septic Tank Systems Recommendations for Domestic Effluent Treatment and Disposal from a single Dwelling House* and/or where septic tank systems have been known to fail.

PART

TECHNICAL SPECIFICATION AND CONTROL DATA

2.1 DESCRIPTION

This Certificate relates to Klargester BioDisc. The Klargester BioDisc has the plan form of a circular tank with tapering or vertical side walls blending into a semi-cylindrical base. The units are constructed from glass-fibre reinforced polyester (GRP) made of chopped strand glass fibres laminated in a polyester resin matrix. The tank is internally divided with a partition wall separating the primary and secondary settlement zones (see Fig. 1). Suspended above and within the primary settlement zone is the GRP Biozone, a semi-cylindrical GRP trough in which the Rotating Biological Contactor (RBC) is housed and rotates. The RBC consists of a hollow rolled section steel shaft with welded stub ends. A rolled steel section framework is built onto the shaft and supports the polypropylene 'media' (see Fig. 1). The shaft and steelwork are zinc metal sprayed or galvanized to protect against corrosion. The shaft is supported on self-aligning plastic bearings and rotated slowly by a motor and gearbox using a reinforced rubber belt and pulley. The Biozone is assembled and supported within the main GRP casing. The RBC is divided using baffles attached to the 'media packs', fixed in the Biozone. The BioDisc unit and all internal mechanical and electrical systems are protected by a GRP cover.

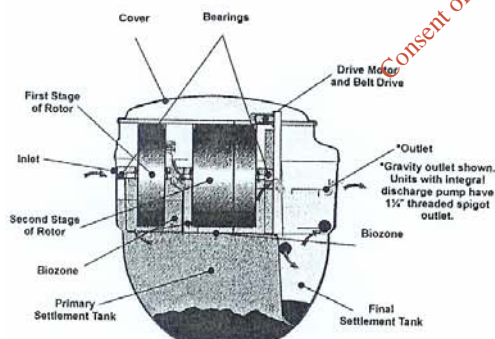

Fig. 1

The inlet and outlet sockets are 110mm diameter PVC-U itemarked to BS EN 1401-1: 1998 (incl. AMD 9132) *Inplastised* PVC underground drain pipes and fittings. Each socket incorporates a captive rubber ring to BS 494: 1997 *Specification for elastomeric seals for joints in pipework and pipelines* and IS EN 681-1: 1996. The sockets are designed to accept PVC-U pipe spigots but

connection to other systems, (eg. vitrified clayware to BS 65: 1991 (1997) *Specification for vitrified clay pipes, fittings and ducts*) or to IS EN 295-1: 1991 (*Vitrified clay pipes and fittings and pipe joints for drains and sewers*) can be made by means of a short length of uPVC pipe to BS 4660: 1989 (1998) (incl. AMD 9132) and appropriate adaptors. BioDiscs which include an integral pump well, will have a 32mm spigot outlet.

Crude sewage passes through the inlet into the primary settlement zone, where the breakdown and storage of solids takes place. The heavier particles sink and settle to form primary sludge and the lighter particles remain in suspension or form a scum on the surface. Both the sludge and scum will begin to break down under the action of bacteria and other organisms. The partly clarified sewage passes through a submerged baffle into the first compartment of the Biozone. The primary sludge and scum are drawn-off by a suction tanker at regular intervals (see Table 1).

The RBC 'media' supports a biologically active film known as Biomass, which is alternately exposed to sewage liquor and air by the rotation of the RBC which is partially immersed in the sewage liquor. The liquor passes through the Biozone after passing through the primary settlement zone (see Fig. 1). Excess biological growth falling off the media in the initial part of the Biozone can pass through the slot at the bottom of this compartment into the primary settlement zone. In the remaining stages of the Biozone, the excess biological growth is kept in suspension by the turbulence created by the rotation of the RBC. The sewage liquor passing through the Biozone is progressively biologically oxidized reducing the organic material content. The resulting purified sewage passes into the final settlement zone, where the excess biological growth (humus solids) either settles or forms floating scum. Sludge from the secondary settlement zone is drawn off at the same intervals as the primary sludge (see Table 1). A facility to return the humus sludge to the primary tank can be provided as an optional extra to the system. If this option is incorporated, sludge removal from the primary tank only will be necessary. Otherwise scum removal from both primary and final settlement tanks should be carried out.

2.2 MANUFACTURE

The main tank is manufactured by spraying from cold setting polyester resin reinforced glass fibres. The cover, Biozone and baffles are made in a similar way. The RBC

'media' is vacuum formed from polypropylene copolymer sheets.

The motor and gearbox are fixed to a galvanized steel bracket which is galvanized to BS EN ISO 1461 (March 1999) *Specification for hot-dip galvanized coatings on iron and steel articles.*

PRODUCT RANGE

The tanks are designed to collect the wastewater and sewage from dwellings having the populations shown in Table 1.

Table 1: BA and BB BioDisc — basic information

Unit size	BA			BB		
	6 (single household)			12 (2 households)		
Population equivalent	6 (single household)			12 (2 households)		
Media area (m ²)	72.5			97.5		
Diameter (mm)	1995			1995		
	shallow	standard	deep	shallow	standard	deep
Inlet invert depth (mm)	450	750	1250	450	750	1250
Outlet invert depth (mm)	520	820	1320	520	820	1320
Height to rim of cover (mm)	1945	2245	2745	1945	2245	2745
Overall height (mm)	2160	2460	2960	2160	2460	2960
Empty weight (tonnes)	0.31	0.325	0.38	0.335	0.35	0.405
Desludge period (approx)	12 months			6 months		
Desludge volume (m ³)	2.6			2.65		
Drive rating 1 phase/ 3 phase (kW)	0.06			0.06		
Approx. daily power consumption (kWh/day)	1.6			1.9		

QUALITY CONTROL

Quality control includes laminate thickness checks on GRP components, plating thickness of zinc and galvanised components and the checking of bought-in components against specification. Each completed unit is checked and test-run for one hour to ensure that it is mechanically sound.

2.3 DELIVERY, STORAGE AND MARKING

The BA and BB BioDisc units are completed ready for delivery at the manufacturer's works. The BioDisc units must be lifted using webbing slings of a suitable specification which must be attached to all the designated lifting points. Lifting equipment should be selected by taking into account the unit weight, dimensions and the distance of lift required on site (see Table 1).

The product bears the marketing company's name, labels denoting the inlet and outlet, a list of all the items supplied, installation and operating instructions, the product specification code, serial number and the inspection date. An external label indicates the IAB identification mark incorporating the certificate number.

2.4 INSTALLATION PROCEDURE

2.4.1 GENERAL

Klargester Environmental Ltd. can advise clients of the installation requirements. Full installation instructions are provided with the equipment. A network of certified installers are available and offer a full installation service.

Electrical connections to the BioDisc unit from the main supplyboard in the dwelling must be carried out by a competent person using material suitable for the purpose.

Electrical connections must be in strict accordance with the manufacturers instructions and must comply with 'The National Rules For Electrical Installations' (ETCI), published by the 'Electro-Technical Council of Ireland' (Document No. ET101 2000).

Cables must be protected from accidental damage by a suitable conduit or other means of protection. The electrical control panel and housing must be sited adjacent to the unit for accessibility but not so close that the panel and BioDisc can be touched simultaneously. The panel must be protected from accidental damage by vehicles.

The BioDisc unit must not be installed in areas liable to localised flooding without adequate protection as specified by the manufacturers.

It is essential to take precautions to prevent damage by site traffic. Superimposed loads from vehicles etc. should not be permitted within a distance equal to the depth of excavation, unless suitable structural protection is provided. A suitable fence may be required to prevent vehicles from approaching too close to the unit.

BioDisc units are installed partly buried so that the rim of the cover is approximately 95mm above ground level. The excavation must be large enough for easy placement of the unit, permit subsequent backfilling and to allow timbering and sheeting as required to meet The Safety, Health and Welfare at Work Act, 1989. (See Fig. 2).

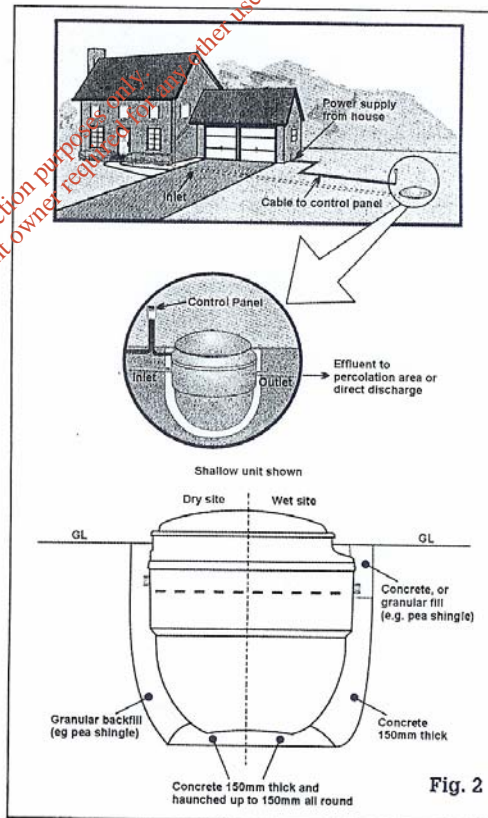

Fig. 2

The units are bedded onto concrete which is haunched up around the base of the unit. The concrete must be of sufficient thickness (minimum 150mm) and grade 25N to ensure that the unit is adequately supported with due regard to sub-soil conditions and loads imposed by the BioDisc when full. (Care must be taken to eliminate voids.) The top flange must be level to within 5mm. In freely draining ground the unit can be backfilled with gravel. In all other circumstances the excavation should be backfilled with a minimum of 225mm thick grade 25N concrete.

The backfill must be carefully consolidated around the BioDisc unit, to ensure even transfer of ground loads and to prevent localised stress concentrations. The BioDisc unit should be ballasted with water keeping the water level just above the backfill level as work progresses.

Pipe Connections

The tank is connected to 110mm diameter PVC-U pipes as required at the inlet and outlet (or 32mm outlet). For other types of pipe such as vitrified clayware etc. suitable adaptors are used with short lengths of PVC-U pipe as necessary. A short length of pipe with flexible joints should be used adjacent to the BioDisc unit to allow for differential movement between the unit and adjacent pipe runs.

2.4.2 LOCATION.

The BioDisc unit location should be chosen so that adequate access is available for safe installation and subsequent maintenance and desludging of the unit. Desludging should be carried out by means of a desludging tanker which requires access to within 30m of the unit, without transgressing the minimum separation distance from the BioDisc unit and the effluent percolation system given in Table 2.

Table 2.

FEATURE	MINIMUM SEPARATION (m)	
	Klargester Recommendation	
	BioDisc	Irrigation Area
Dwelling served	7 ⁽¹⁾	5
Adjacent dwelling	10 ⁽¹⁾	5
Wall	3 ⁽¹⁾	3
Road	3 ⁽¹⁾	3
Site boundary	3	3
Potable water source	10	30-100 ⁽²⁾
Watercourse	3	3

- (1) The depth of the excavation to accommodate the BioDisc must be taken into account when determining this distance. The separation distance should be such that the excavation does not undermine adjacent buildings, roads or walls. This distance should not be less than 1.5 times the excavation depth.
- (2) This separation distance should not be less than 30 metres except in the case of very free draining soils or gravels, where a minimum distance of 40 metres should be maintained. The irrigation area should be downhill of any nearby well. Where this is not possible a separation distance of at least 100 metres must apply
- (3) These are minimum permissible distances. However, where the site permits, irrigation areas should be located at greater separation distances from the dwelling. Also where practical on sloping sites the irrigation area should be down slope from the dwelling.

2.4.3 TREATED WASTEWATER DISPOSAL

The BioDisc produces a fully treated wastewater which is more easily absorbed into soil strata than septic tank effluent.

Two methods are recommended for the disposal of treated wastewater:

- a) Sub-surface irrigation.
- or
- b) Discharge to surface water, either directly or following a polishing filter.

The choice of disposal method will be largely determined by the percolation characteristics of the site soil, which can be quantified by various criteria, notably the "T" value resulting from a percolation test, as set out in SR6: 1991.

Treated wastewater may be discharged from the BioDisc unit either by gravity, or when site conditions demand, by pumping. BioDisc units with integral discharge pumps are available for this purpose.

Site Assessment

To determine the most appropriate method of sewage treatment/disposal a three step assessment procedure is recommended.

- Consultation and visual inspection
- Trial hole
- Percolation test (e.g. Standard "T" test)

The results of this assessment will enable the selection of the most suitable method for disposing of the final treated wastewater, having regard to soil type and percolation characteristics, water table level and other factors. The disposal method will be either to sub-surface percolation, raised percolation bed or direct to surface waters, by licence which should be obtained from the relevant local authority. Reference should also be made to the publication - *Ground Water Protection Responses for On-Site Wastewater Systems for Single Houses* published by EPA/DOELG/GSI (2001).

Table 3: Soil Types and Percolation Areas.

Soil	Description	Percolation Characteristics	T Values Mins/25mm	Linear metres of pipe (1 metre wide trench)	
				Up to 6 Persons	7-12 Persons
Type					
A [†]	Sand Gravel	Very Good	>5 <10	10	20
B	Sandy Loam. Loam. Clay Loam.	Good	>10<30	20	40
C	Silty Loam. Clay Loam.	Moderate	>30<60	60	120
D*	Sandy Clay. Silty Clay. Clay	Poor	>60	—	—

[†]For percolation values (T) <5 consult the manufacturer

*For percolation values (T) >60 discharge direct to surface waters or a raised percolation bed.

Sub-surface percolation

- a) The treated wastewater discharges, by pump or by gravity, into a network of perforated pipes laid in stone filled trenches. The objective is to spread the wastewater as evenly as possible over the required land area, thus minimising the possibility of the ground becoming over saturated.

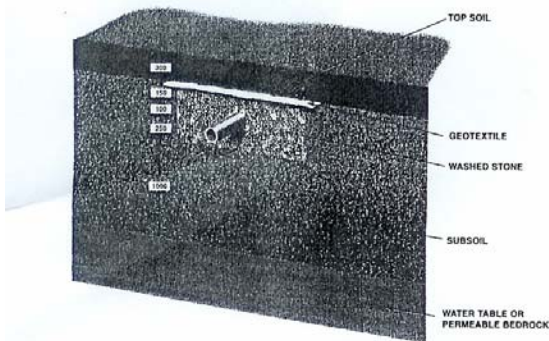

Figure 3(a): Section through effluent distribution trench (Gravity feed).

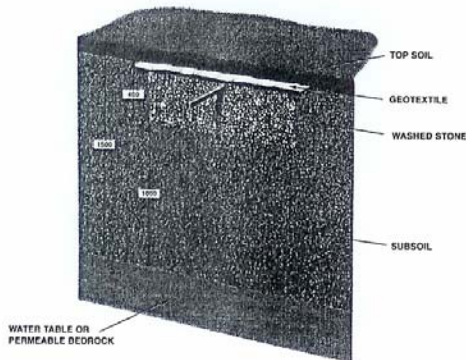

Figure 3(b): Section through effluent distribution trench (Pumped feed).

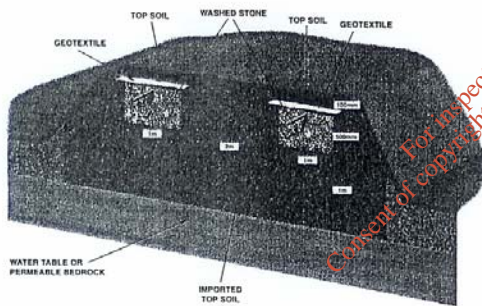

Figure 4: Section through a raised bed system used in areas of high water table.

BioDisc discharge has minimal suspended solids and is therefore, much more readily absorbed than septic tank effluent. The extent of the irrigation system may be determined by the site assessment, taking into account the soil type and percolation test results, as well as the population to be served; (see table 3). These values are given for guidance only and should be discussed in detail with the site surveyor.

The percolation area will be equivalent to the linear pipe length shown above (assuming 1 metre wide trenches)

For pumped discharges the perforated pipe is 32mm diameter (see figure 3b). For gravity discharges the perforated pipe is 100mm diameter (see Figure 3a). Trenches are generally 300-1000mm wide with the pipes laid on 250mm of clean 15-25mm stone and covered with a polythene or geo-textile soil barrier. Layout of the trenches will be determined by site topography; the overall fall of the pipes should be not more than 1 in 200. The pipes should be at least 1 metre above the highest water table level or fissured rock strata.

- Where the irrigation pipes have to be above existing ground level, e.g. thin topsoils and/or rock or water table close to the surface, a banked-up irrigation system may be suitable. It is generally similar to sub-surface percolation. See Figure 4.
- For situations where the percolation area is at a higher level, BioDisc is available with an integral discharge pump. Separate effluent pump sets are also available if necessary.

Discharge to a watercourse

Where poor soil percolation or other factors make a sub-surface irrigation system impractical, discharge to a watercourse may be considered. This will require a licence from the relevant local authority, setting the minimum acceptable discharge quality. Typical detail of a discharge to a water course is shown in Figure 5. The treated wastewater is filtered through a layer of sand or topsoil before passing to the watercourse.

In some circumstances direct discharge to a water course may be permitted.

Access to all effluent percolation systems should be provided at the end of each irrigation or filter trench via a suitably constructed AJ.

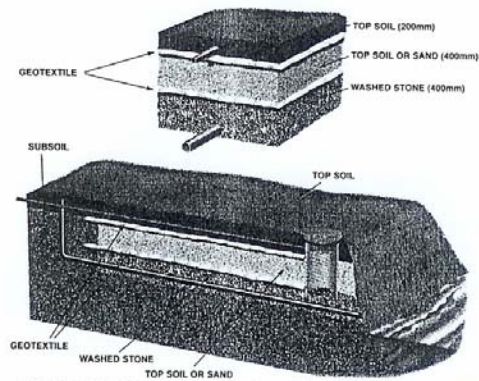

Figure 5: Section through a drainage system used to discharge to water courses

Further treatment

In some instances (e.g. proximity to a drinking water source), the wastewater may require "polishing" before discharge to reduce coliform bacteria levels. A commonly used method is to pass the discharge through a sand filter. The BioDisc discharge is pumped to the filter using an effluent pump set capable of discharging in 180 litre doses.

Polishing filters can be partly or wholly above ground, soil covered or open. A typical filter serving a 4 person household would have a plan area of 8-20m², depending on design and type of sand used.

N.B. Disinfection systems may also be used in consultation with the manufacturer.

2.5 Commissioning:

Commissioning is an additional service which should be carried out after installation by a qualified person and this service is available from the installer or designated service provider.

PART

3

DESIGN DATA

3.1 GENERAL

The Klargestar BioDisc is *suitable* for the collection and treatment of domestic sewage and should be installed in accordance with the manufacturer's instructions and to conform with the recommendations of BS 6297: 1983 *Code of practice for the design installation of small sewage treatment works and cesspools*. It is important that the loadings are based on the maximum population to be served.

BioDisc units should be sited in accordance with the relevant Building Regulations.

Ground water and flood levels should always be below plant outlet level, unless specific arrangements have been made to overcome this problem.

The discharge of the unit must be to a suitable sub-soil irrigation system or water course to the requirements of the relevant local authority.

The effluent resulting from the sewage treated by the BioDisc unit will normally be within Royal Commission Standard (ie suspended solids content less than 30 mg per litre and Biochemical Oxygen Demand (BOD) less than 20 mg per litre) provided that the hydraulic and BOD loadings are within the limits recommended by the manufacturer for the unit installed (200 litres per head per day and 60 grammes per head per day, respectively). Under certain unusual conditions the resulting effluent may not be within Royal Commission Standards. This is normal for any biological sewage treatment process, and can be caused by unusual hydraulic or BOD loading, weather conditions, contamination by grease, or

poisoning of microbiological fauna or flora by chemicals.

3.2 Design Basis

The sizes and relevant dimensions of BioDisc units certified are shown in Table 1.

The units can be fitted with a warning device which activates an alarm when the RBC has ceased rotation for any reason other than a mains power supply failure.

3.2.1 WASTEWATER QUALITY

Table 4: Treated wastewater characteristics:

	Standard	Optional*
pH		6-9
Biochemical oxygen demand	< 20 mg/l	
Suspended Solids	< 30 mg/l	
Ammonia	< 20 mg/l	< 5 mg/l
Nitrate		< 5 mg/l
Total Phosphorus		< 1 mg/l
E. coli (by soil treatment or disinfection)		

* An option units are available to meet these performance levels for ammonia, nitrate and total phosphorus – details on request from the manufacturer.

The BioDisc can be used to provide temporary sewage treatment facilities. A short period of acclimatisation must be allowed after commissioning of the unit before a full degree of treatment can be expected. This period is generally a few weeks and is normal for any biological treatment plant.

PART

4

TECHNICAL INVESTIGATIONS

4.1 ENVIRONMENTAL ASSESSMENT

The treated wastewater from a number of working installations has been comprehensively monitored for 12 months. The test results show that values stated for the parameters listed in Table 4 are consistently achievable over a range of operating conditions.

4.2 STRENGTH

The manufacturer's design has been assessed as satisfactory. The BioDisc has adequate resistance to resist damage from minor impacts during handling but it must be slung and supported at the points recommended and marked by the manufacturer. The BioDisc has sufficient structural strength to resist soil loads in non-cohesive dry soils, but it is recommended

that BioDisc units are backfilled with dense mass concrete to resist upthrust due to buoyancy in high water table sites.

BioDisc covers are not suitable for walking on. Where necessary the unit should be fenced off or otherwise protected.

4.3 LIQUID WATER PENETRATION

The BioDisc with its pipe connections, when correctly installed has been assessed as fully capable of preventing seepage either into or from the surrounding soil. The pipe joints, when correctly made, will be watertight.

4.4 DURABILITY

The structural properties of the GRP from which the tank is constructed, in common with all similar materials, will deteriorate with time. This deterioration is accelerated by contact with ground water, sewage and dissolved or suspended organic or inorganic compounds. The resulting loss of strength or stiffness has been taken into account in the manufacturer's design code. The GRP components should remain serviceable for at least 30 years. Protected steel components may require further protection by painting, but this should not be required for at least 15 years. The mechanical and electrical components are liable to wear during operation, but the design layout is such that they can be replaced as required.

4.5 CLEANING AND MAINTENANCE

Cleaning and maintenance should be carried out in accordance with the *Operation and Maintenance Instructions* supplied by Klargest Environmental Ltd.

Summary of maintenance instructions

The BioDisc is desludged by a suction tanker. Care must be taken to avoid damage by the hose nozzle. Both the primary and secondary settlement zones must be desludged in accordance with the manufacturer's recommendations for the particular size of BioDisc. (See Table 1).

Local damage to GRP components can be repaired by the manufacturer or a suitably experienced person using standard GRP repair techniques. Any repairs must be carried out in dry conditions, and the GRP laminate to be repaired, must be thoroughly cleaned, dried, lightly abraded and prepared with a suitable bonding agent.

Regular maintenance generally involves a visual examination of the Biozone, removal of the debris, cleaning the weir and checks on the belt transmission.

Rust spots on steelwork should be wire brushed and coated with a zinc based paint.

Flooding

Repair or replacement may be required should the mechanical and electrical components be subject to damage in the event of flooding.

4.6 SAFETY

4.6.1 SAFETY OF PERSONNEL

The tank cover is securely fixed to prevent unauthorised access. The cover must not be left off an unattended tank. The manufacturers provide a locking device to the cover to ensure that they can not be removed without keys. Tanks are potentially dangerous, particularly when being desludged. Desludging must never be carried out alone. Tank entry should not be attempted except by trained personnel. Naked flames which can cause explosions must not be used in the vicinity of the tanks.

The BioDisc should be positioned, or marked, or protected, to prevent superimposed loading or accidental impact by vehicles.

4.7 TESTS AND ASSESSMENTS WERE CARRIED OUT TO DETERMINE

Tests were carried out to determine:

- Resin/glass ratio Based on BS 4994: 1987
- Barcol hardness, based on BS 4549: Part 1: 1997
- Cross breaking strength by water boil, based on methods in BS 3532: 1990 (1995) Appendix C and BS 2782: Method 335 A: 1993.
- Degree of cure, by the Coggeshall test.
- Water soak test based on BS 2782: Part 4: Method 430A: 1983.
- The durability of the GRP on prolonged exposure to water was assessed by exposing samples to boiling water for 1000 hours and then measuring any loss in cross breaking strength, bending stiffness or ductility.
- Watertightness.
- Strength of cover and frame assemblies.
- Hydrostatic testing of complete tanks was carried out to check the validity of the manufacturer's design, with respect to buckling and fracture of the tank, when subjected to external pressure.
- Resistance of units to hydrostatic and ground pressure.
- Resistance to flotation
- Environmental performance

4.8 OTHER INVESTIGATIONS

- (i) Existing data on the history of use of previous installations.
- (ii) The manufacturing process was examined including the methods adopted for quality control, and details were obtained of the quality and composition of the materials used.
- (iii) An examination of the results of sample analyses of effluent from BioDisc units to measure suspended solids content and Biochemical Oxygen Demand was undertaken.
- (iv) An assessment of the tank was made in relation to degradation of mechanical properties arising from exposure to sewage, ground water, dissolved salts, dilute acids or alkalis and long-term loading conditions.

Structural steel components;

Specification and durability of the corrosion protection process.

Bought in components

- (v) Suitability for use.
Site visits were conducted to assess the practicability of installation.
A user survey and visits to established sites were conducted to evaluate performance in use.
No failures of the product in use have been reported to the IAB.

5.1 CONDITIONS OF CERTIFICATION

The National Standards Authority of Ireland ("NSAI") following consultation with the Irish Agrément Board ("IAB") has assessed the performance and method of installation of the product/process and the quality of the materials used in its manufacture and certifies the product/process to be fit for the use for which it is certified provided that it is manufactured, installed, used and maintained in accordance with the descriptions and specifications set out in this certificate and in accordance with the manufacturer's instructions and usual trade practice. This certificate shall remain valid so long as:

- (a) the specification of the product is unchanged;
 - (b) the Building Regulations, 1997 to 2000 and any other regulation or standard applicable to the product/process, its use or installation remain unchanged;
 - (c) the product continues to be assessed for the quality of its manufacture and marking by NSAI;
 - (d) no new information becomes available, which in the opinion of the NSAI would preclude the granting of the certificate;
 - (e) the product or process continues to be manufactured, installed, used and maintained in accordance with the description, specifications and safety recommendations set out in this certificate.
- 5.2 The IAB mark and certification number may only be used on or in relation to products/processes in respect of which a valid certificate exists. If the certificate becomes invalid, the certificate holder must not use the IAB mark and certification number and must remove them from products already marked.
- 5.3 In granting this certificate, the NSAI makes no representation as to:

- (a) the presence or absence of patent rights subsisting in the product/process; or
- (b) the legal right of the certificate holder to market, install or maintain the product/process; or
- (c) whether individual products have been manufactured or installed by the certificate holder in accordance with the descriptions and specifications set out in this certificate.

- 5.4 This certificate does not comprise installation instructions and does not replace the manufacturer's directions or any professional or trade advice relating to use and installation which may be appropriate.
- 5.5 Any recommendations contained in this certificate relating to the safe use of the certified product or process are preconditions to the validity of the certificate. However, the NSAI does not certify that the manufacture or installation of the certified product or process in accordance with the descriptions and specifications set out in this certificate will satisfy the requirements of the Safety, Health and Welfare at Work Act, 1989 or of any other current or future statute or current or future common law duty of care owed by the manufacturer or by the certificate holder.
- 5.6 The NSAI is not responsible to any person or body for loss or damage, including personal injury, arising as a direct or indirect result of the use of this product or process.
- 5.7 Where reference is made in this certificate to any Act of the Oireachtas, regulation made thereunder, statutory instrument, code of practice, national standards, manufacturer's instructions or similar publication, it shall be construed as reference to such publication in the form in which it is in force at the date of this certification.

THE IRISH AGRÉMENT BOARD

This Certificate No. 01/0094 is accordingly granted to Klargester Environmental on behalf of the Irish Agrément Board.

Date of Issue: July 1997

Signed:



Chief Executive, NSAI

Readers may check that the status of this Certificate has not changed by contacting the Irish Agrément Board, NSAI, Glasnevin, Dublin 9, Ireland.

Telephone: (01) 8073800.
Telefax: (01) 8073842.

Re-Printed November 2001



BUILDING PRODUCT CERTIFICATION

Irish Agrément Board,
NSAI,
Glasnevin,
Dublin 9,
Ireland.
Telephone: (01) 8073800.
Telefax: (01) 8073842.